

Charmed meson hadronic decays at BESIII

Bai-Cian Ke
Zhengzhou University



@ 強子物理論壇 2026 May 29

BESIII Data Taken near Threshold

- 20.3 fb^{-1} at $E_{\text{cm}} 3.773 \text{ GeV}$: $e^+e^- \rightarrow \psi(3770) \rightarrow D\bar{D}$
- 7.33 fb^{-1} at $E_{\text{cm}} 4.128 - 4.226 \text{ GeV}$: $e^+e^- \rightarrow D_s D_s^*$

Production of charm hadron pair

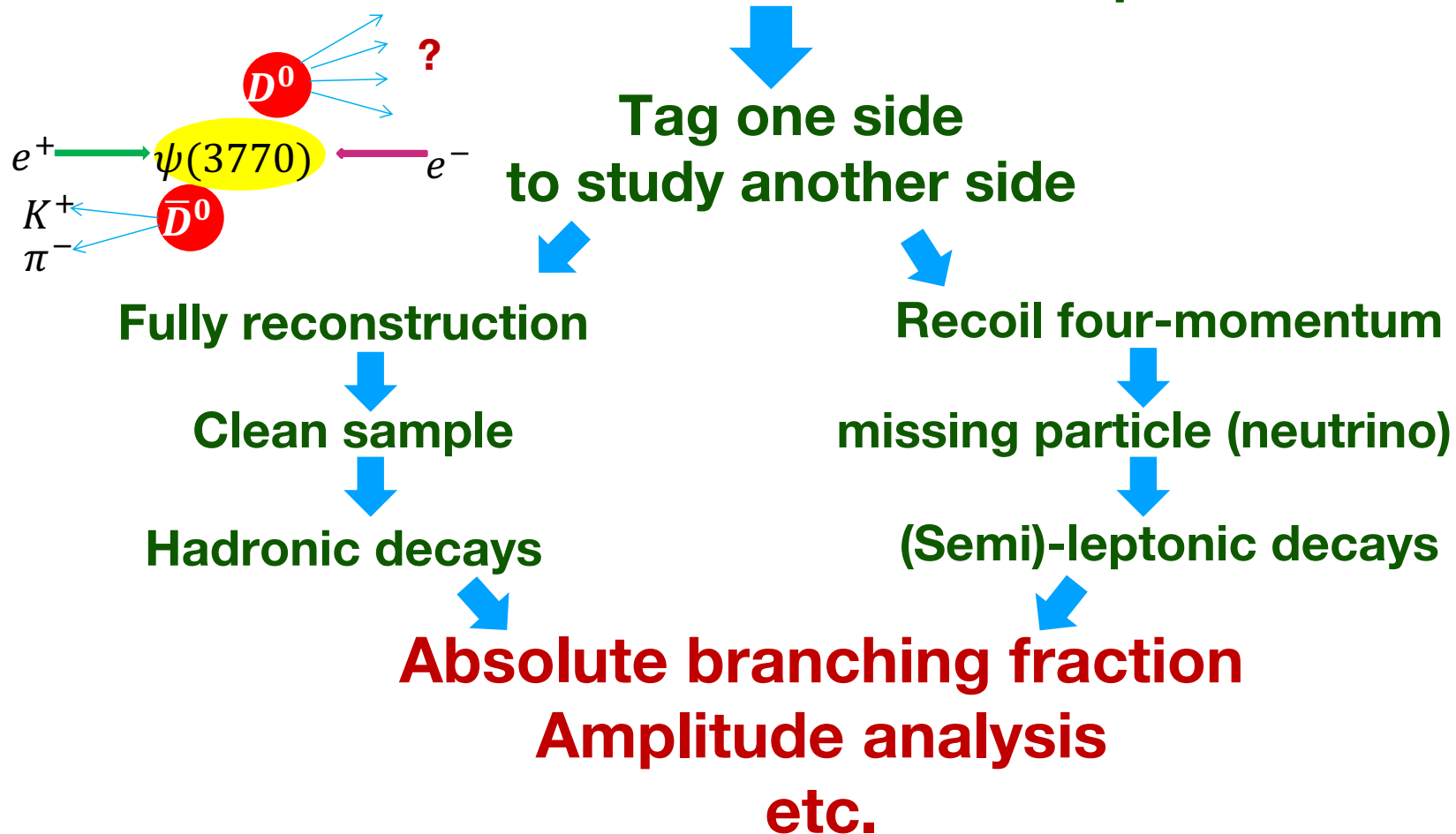

Hadronic decays of charmed mesons

- **Topological Diagram Approach--Understand SU(3) breaking, addressing the source of CP violation.**

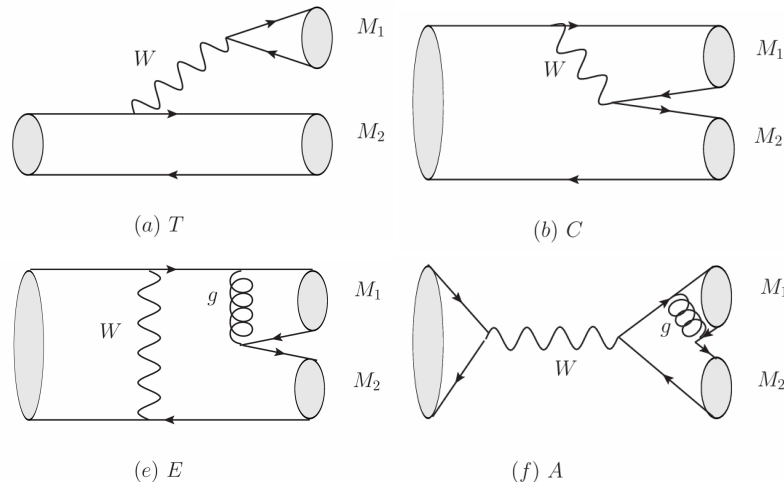

Mode	Amplitude
$D^0 \rightarrow K^+ \pi^-$	$\lambda_{ds}(1.23T + E)$
$D^0 \rightarrow K^0 \pi^0$	$\frac{1}{\sqrt{2}}\lambda_{ds}(C - E)$
$D^0 \rightarrow K^0 \eta$	$\lambda_{ds} \left[\frac{1}{\sqrt{2}}(C + E) \cos \phi - E \sin \phi \right]$
$D^0 \rightarrow K^0 \eta'$	$\lambda_{ds} \left[\frac{1}{\sqrt{2}}(C + E) \sin \phi + E \cos \phi \right]$
$D^+ \rightarrow K^0 \pi^+$	$\lambda_{ds}(C + 0.71A)$
$D^+ \rightarrow K^+ \pi^0$	$\frac{1}{\sqrt{2}}\lambda_{ds}(1.23T - 0.71A)$
$D^+ \rightarrow K^+ \eta$	$\lambda_{ds} \left[\frac{1}{\sqrt{2}}(1.05T + A) \cos \phi - 0.81A \sin \phi \right]$
$D^+ \rightarrow K^+ \eta'$	$\lambda_{ds} \left[\frac{1}{\sqrt{2}}(1.05T + A) \sin \phi + 0.81A \cos \phi \right]$
$D_s^+ \rightarrow K^0 K^+$	$\lambda_{ds}(1.27T + 1.03C)$

- **$D \rightarrow PP$: high efficiency, low background, no interference, (usually) high precision. Good for A_{CP} , $\eta - \eta'$ mixing etc..**
- **$D \rightarrow SP, D \rightarrow SV, (D \rightarrow SS)$: Understand the nature of light scalar mesons, $a_0(980), f_0(980), K(700), f_0(500)$ etc..**
- **$D \rightarrow VP$: Clarifying the nonperturbative mechanism. Better than the PP and VV, due to the multiple-amplitude composition of P and the polarization in VV.**
- **$D \rightarrow VV$: Polarization in charmed decays.**
- **$D \rightarrow AP$: Study axial-vector mesons, $a_1(1260) K_1(1400)$ etc..**

BF of D_s^+ hadronic decays

Method: Double Tag

Data: 7.33 fb⁻¹ 4.128 - 4.226 GeV

JHEP 05(2024)335

Global fit
15 decay modes

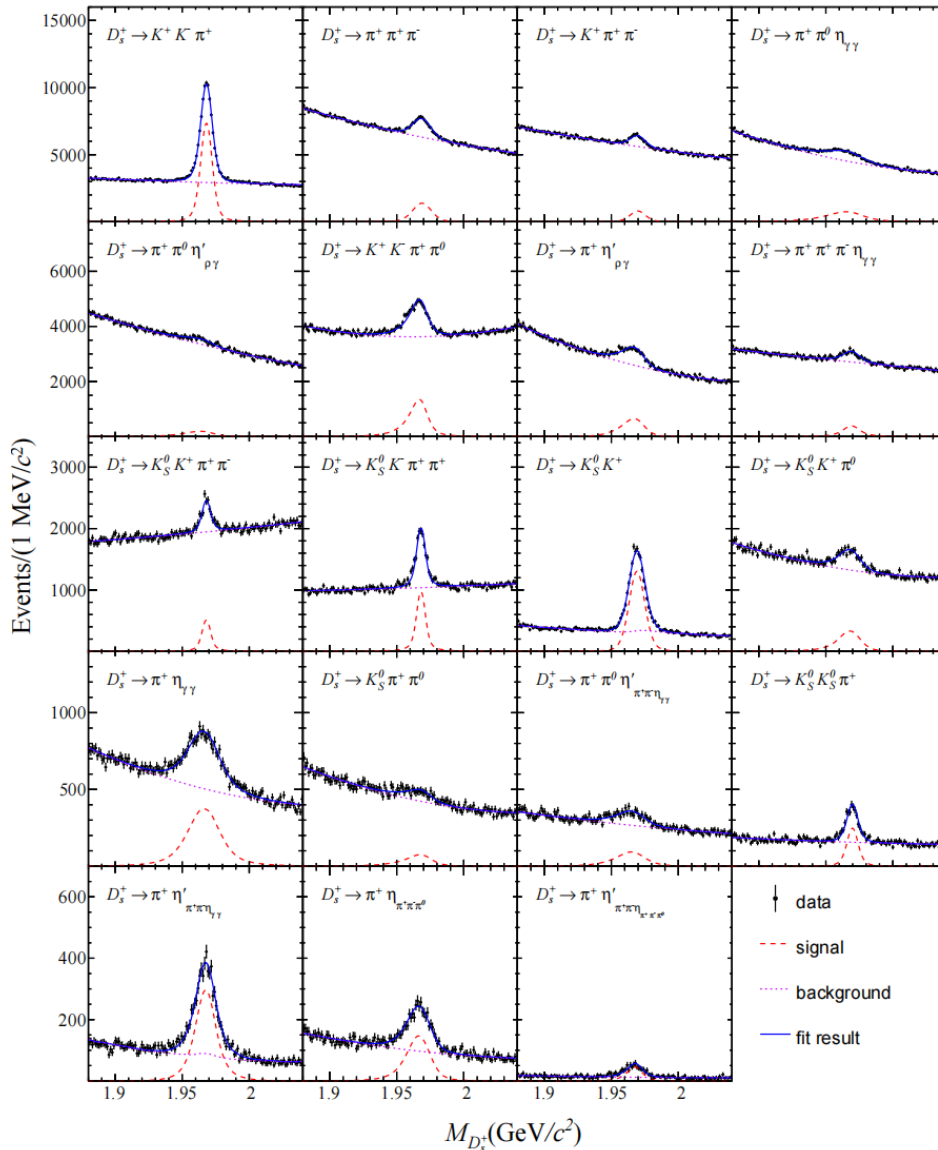

Mode	\mathcal{B} (%)	PDG \mathcal{B} (%)
$D_s^+ \rightarrow K_S^0 K^+$	$1.502 \pm 0.012 \pm 0.009$	1.453 ± 0.035
$D_s^+ \rightarrow K^+ K^- \pi^+$	$5.49 \pm 0.04 \pm 0.07$	5.37 ± 0.10
$D_s^+ \rightarrow K_S^0 K^+ \pi^0$	$1.47 \pm 0.02 \pm 0.02$	1.47 ± 0.07
$D_s^+ \rightarrow K_S^0 K_S^0 \pi^+$	$0.73 \pm 0.01 \pm 0.01$	0.71 ± 0.04
$D_s^+ \rightarrow K^+ K^- \pi^+ \pi^0$	$5.50 \pm 0.05 \pm 0.11$	5.50 ± 0.24
$D_s^+ \rightarrow K_S^0 K^+ \pi^+ \pi^-$	$0.93 \pm 0.02 \pm 0.01$	0.95 ± 0.08
$D_s^+ \rightarrow K_S^0 K^- \pi^+ \pi^+$	$1.56 \pm 0.02 \pm 0.02$	1.53 ± 0.08
$D_s^+ \rightarrow \pi^+ \pi^+ \pi^-$	$1.09 \pm 0.01 \pm 0.01$	1.08 ± 0.04
$D_s^+ \rightarrow \pi^+ \eta$	$1.69 \pm 0.02 \pm 0.02$	1.67 ± 0.09
$D_s^+ \rightarrow \pi^+ \pi^0 \eta$	$9.10 \pm 0.09 \pm 0.15$	9.5 ± 0.5
$D_s^+ \rightarrow \pi^+ \pi^+ \pi^- \eta$	$3.08 \pm 0.06 \pm 0.05$	3.12 ± 0.16
$D_s^+ \rightarrow \pi^+ \eta'$	$3.95 \pm 0.04 \pm 0.07$	3.94 ± 0.25
$D_s^+ \rightarrow \pi^+ \pi^0 \eta'$	$6.17 \pm 0.12 \pm 0.14$	6.08 ± 0.29
$D_s^+ \rightarrow K_S^0 \pi^+ \pi^0$	$0.51 \pm 0.02 \pm 0.01$	0.54 ± 0.03
$D_s^+ \rightarrow K^+ \pi^+ \pi^-$	$0.620 \pm 0.009 \pm 0.006$	0.620 ± 0.019



much improved precision!!!

Achieved the desired goal
of D_s^+ BF measurement!⁴

\mathcal{A}_{CP} calculation

JHEP 05(2024)335

Mode	\mathcal{A}_{CP} (%)	PDG \mathcal{A}_{CP} (%)
$D_s^\pm \rightarrow K_S^0 K^\pm$	$0.29 \pm 0.50 \pm 0.21$	0.09 ± 0.26
$D_s^\pm \rightarrow K^+ K^- \pi^\pm$	$0.48 \pm 0.26 \pm 0.24$	-0.5 ± 0.9
$D_s^\pm \rightarrow K_S^0 K^\pm \pi^0$	$-0.85 \pm 1.97 \pm 0.46$	-2 ± 6
$D_s^\pm \rightarrow K_S^0 K_S^0 \pi^\pm$	$1.14 \pm 1.58 \pm 0.44$	3 ± 5
$D_s^\pm \rightarrow K^+ K^- \pi^\pm \pi^0$	$-0.66 \pm 0.91 \pm 0.33$	0.0 ± 3.0
$D_s^\pm \rightarrow K_S^0 K^\pm \pi^+ \pi^-$	$2.00 \pm 2.37 \pm 0.70$	-6 ± 5
$D_s^\pm \rightarrow K_S^0 K^\mp \pi^\pm \pi^\pm$	$-0.24 \pm 1.05 \pm 1.07$	4.1 ± 2.8
$D_s^\pm \rightarrow \pi^\pm \pi^+ \pi^-$	$-0.88 \pm 1.17 \pm 0.38$	-0.7 ± 3.1
$D_s^\pm \rightarrow \pi^\pm \eta$	$-0.44 \pm 0.89 \pm 0.19$	0.3 ± 0.4
$D_s^\pm \rightarrow \pi^\pm \pi^0 \eta$	$1.05 \pm 1.45 \pm 0.62$	-1 ± 4
$D_s^\pm \rightarrow \pi^\pm \pi^+ \pi^- \eta$	$2.42 \pm 2.85 \pm 0.78$	-
$D_s^\pm \rightarrow \pi^\pm \eta'$	$-0.59 \pm 0.76 \pm 0.20$	-0.9 ± 0.5
$D_s^\pm \rightarrow \pi^\pm \pi^0 \eta'$	$-1.60 \pm 2.57 \pm 0.64$	0 ± 8
$D_s^\pm \rightarrow K_S^0 \pi^\pm \pi^0$	$-2.17 \pm 4.65 \pm 1.10$	3 ± 6
$D_s^\pm \rightarrow K^\pm \pi^+ \pi^-$	$1.81 \pm 2.01 \pm 0.45$	4 ± 5

published Ds Amplitude analyses

$D_s^+ \rightarrow K^+ K^- \pi^+$	Phys. Rev. D 104 (2021) 012016
$D_s^+ \rightarrow K_S^0 K^+ \pi^0$	Phys. Rev. Lett. 129 (2022) 182001
$D_s^+ \rightarrow \pi^+ \pi^+ \pi^-$	Phys. Rev. D 106 (2022) 112006
$D_s^+ \rightarrow \pi^+ \pi^+ \pi^- \eta$	Phys. Rev. D 104 (2021) L071101
$D_s^+ \rightarrow \pi^+ \pi^0 \eta'$	JHEP 04 (2022) 058
$D_s^+ \rightarrow \pi^+ \pi^0 \pi^0$	JHEP 01 (2022) 052
$D_s^+ \rightarrow K^+ \pi^+ \pi^-$	JHEP 08 (2022) 196
$D_s^+ \rightarrow K^+ \pi^+ \pi^- \pi^0$	JHEP 09 (2022) 242
$D_s^+ \rightarrow K_S^0 K_S^0 \pi^+$	Phys. Rev. D 105 (2022) L051103
$D_s^+ \rightarrow K_S^0 K^- \pi^+ \pi^+$	Phys. Rev. D 103 (2021) 092006
$D_s^+ \rightarrow K^+ K^- \pi^+ \pi^0$	Phys. Rev. D 104 (2021) 032011
$D_s^+ \rightarrow K^+ K^- \pi^+ \pi^+ \pi^-$	JHEP 07 (2022) 051
$D_s^+ \rightarrow K_S^0 \pi^+ \pi^0$	JHEP 06 (2021) 181
$D_s^+ \rightarrow \pi^+ \pi^0 \eta$	Phys. Rev. Lett. 123 (2019) 112001
$D_s^+ \rightarrow \pi^+ \pi^+ \pi^- \pi^0$	Phys. Rev. Lett. 134 (2025) 011904
$D_s^+ \rightarrow \pi^+ \pi^+ \pi^- \pi^0 \pi^0$	Phys. Rev. Lett. 134 (2025) 201902
$D_s^+ \rightarrow K_S^0 K_L^0 \pi^+$	Phys. Rev. Lett. 135 (2025) 161902
$D_s^+ \rightarrow \pi^+ \pi^0 \pi^0 \eta$	arXiv 2603.18521

No significant asymmetries are observed.

Why Amplitude Analysis?

- Must first recognize the respective limitations of particle physics experiments and theories.
- **Experiments:** e, μ, π, K, p , and γ as well as $\pi^0/\eta, K_S^0$ as final state particles.
- **Theory:** only estimates for two-body decays are available.
- For example, $D^0 \rightarrow K^{*0}\pi^0 \rightarrow K^-\pi^+\pi^0$ and $D^0 \rightarrow K^{*-}\pi^+ \rightarrow K^-\pi^+\pi^0$.
- Extracting intermediate processes from measured final-state particles is essential for connecting experiments and theories.
- Amplitude analysis provides the key solution for achieving this goal.

$$\mathcal{M}(p) = \sum c_n \mathcal{A}_n(p)$$

Total amplitude \rightarrow $\mathcal{M}(p)$ \leftarrow Amplitudes of intermediate processes

$$c_n = \rho_n e^{i\phi_n}$$

Magnitudes and phases: free parameters in fits

Amplitude analysis of $D^+ \rightarrow K_S^0 K_S^0 \pi^+$

✓ Precise measurement of $D^+ \rightarrow K_S^0 K^*(892)^+$

PRD 110.092006 (2024)

7.93fb⁻¹@ $E_{cm}=3.773$ GeV
1177 candidates with >89% purity

$D \rightarrow VP$

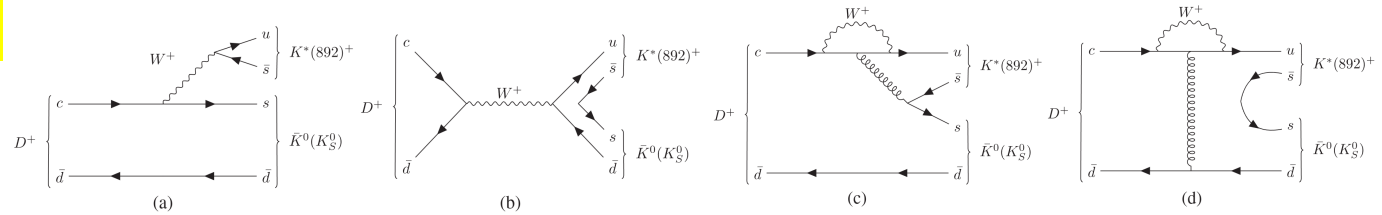
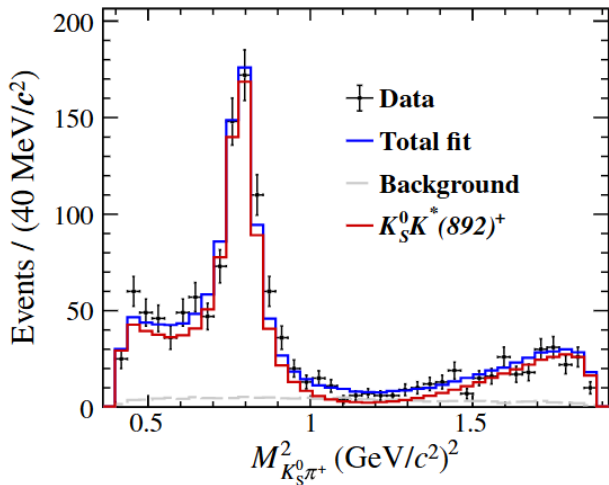
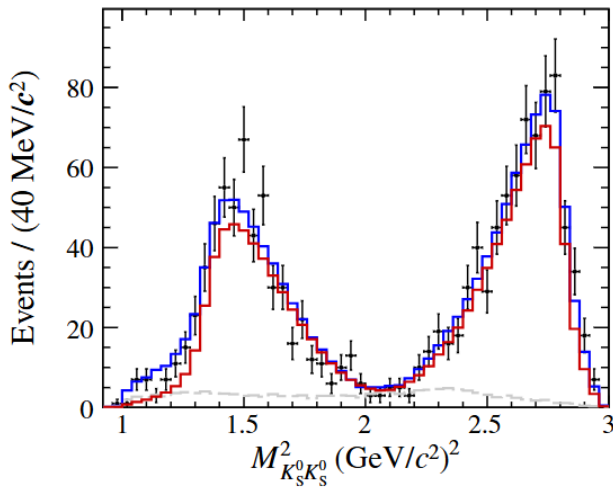

TABLE I. Theoretical predictions of $\mathcal{B}(D^+ \rightarrow K_S^0 K^*(892)^+)$ and the previous experimental measurement.

Model	$\mathcal{B}(D^+ \rightarrow K_S^0 K^*(892)^+) (\times 10^{-3})$
Pole [12]	6.2 ± 1.2
FAT (mix) [13]	5.5
TDA (tree) [1]	5.02 ± 1.31
TDA (QCD-penguin) [2]	4.90 ± 0.21
TDA [14]	7.90 ± 0.25
BESIII measurement [11]	$8.69 \pm 0.40_{\text{stat}} \pm 0.64_{\text{syst}} \pm 0.51_{\text{BF}}$

$(8.72 \pm 0.28_{\text{stat.}} + 0.15_{\text{syst.}}) \times 10^{-3}$

PRD 104, 012006

Consistent with the previous BESIII measurement but with improved precision

Amplitude analysis of $D^0 \rightarrow K_S^0 \pi^0 \pi^0$

arxiv:2510.25111

☯ Dominant contribution $D^0 \rightarrow \bar{K}^*(892)^0 \pi^0$

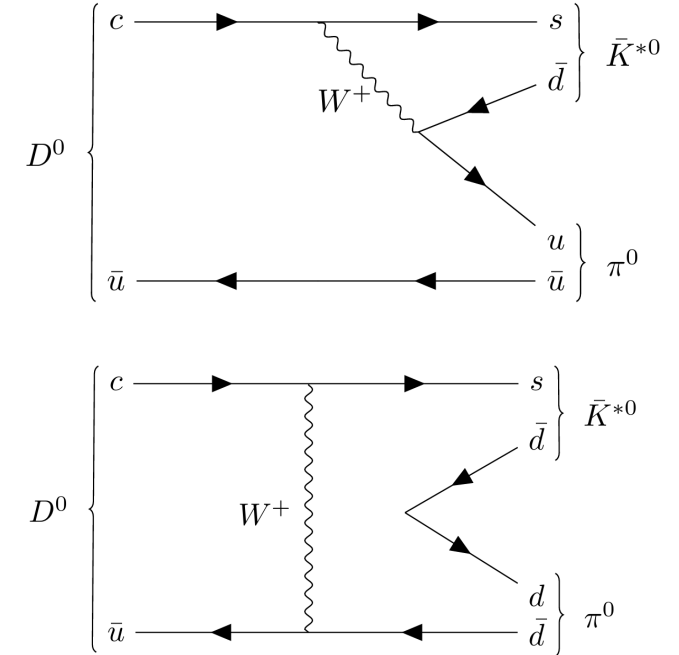
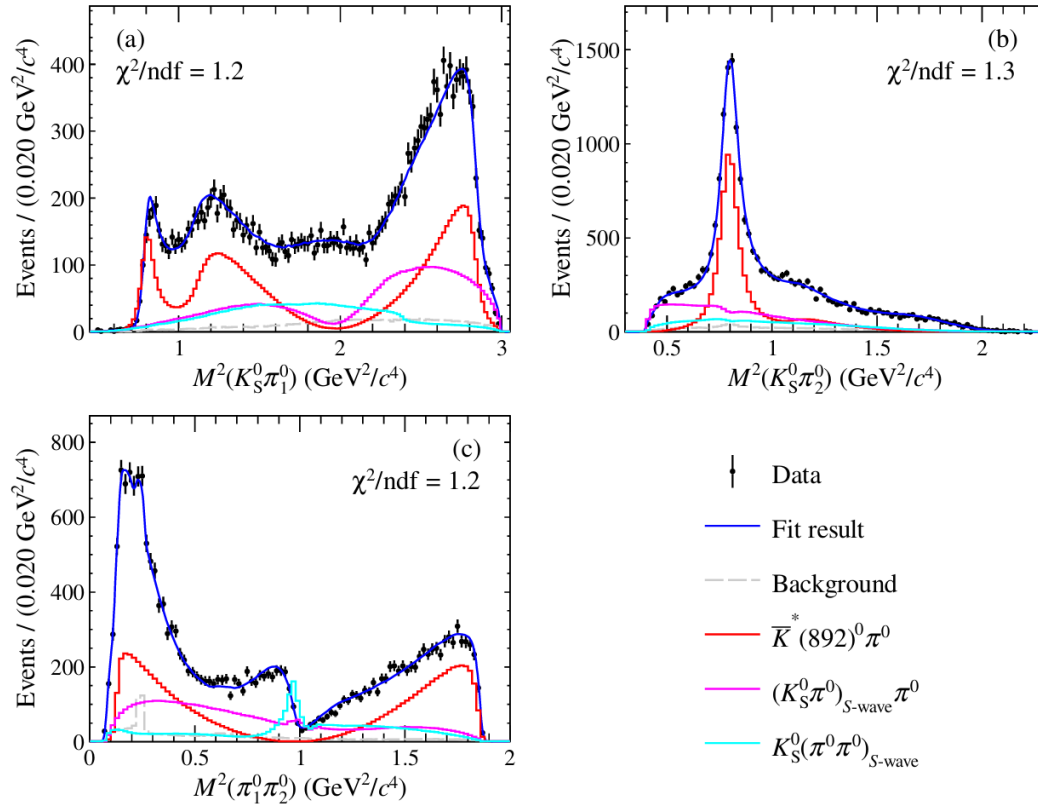

Precise BF measurement of $D^0 \rightarrow K_S^0 \pi^0 \pi^0$

$$\mathcal{B}(D^0 \rightarrow K_S^0 \pi^0 \pi^0) = (1.026 \pm 0.008_{\text{stat.}} \pm 0.009_{\text{syst.}})\%$$

consistent with PDG value $(0.91 \pm 0.11)\%$
with precision improved by a factor of 10

Amplitude	$\mathcal{B}(D^0 \rightarrow \bar{K}^{*0} \pi^0)$ (%)
TDA	3.61 ± 0.18
FAT [mix]	3.25
pole	2.9 ± 1.0
CLEO [from $D^0 \rightarrow K^- \pi^+ \pi^0$]	$2.74 \pm 0.23(\text{stat.}) \pm 0.41(\text{syst.})$
CLEO [from $D^0 \rightarrow K_S^0 \pi^0 \pi^0$]	$4.16 \pm 0.37(\text{stat.}) \pm 0.33(\text{syst.})$
This work	$2.46 \pm 0.06(\text{stat.}) \pm 0.04(\text{syst.})$

Amplitude analysis of $D^+ \rightarrow \pi^+ \pi^0 \pi^0$

arXiv 2512.12397

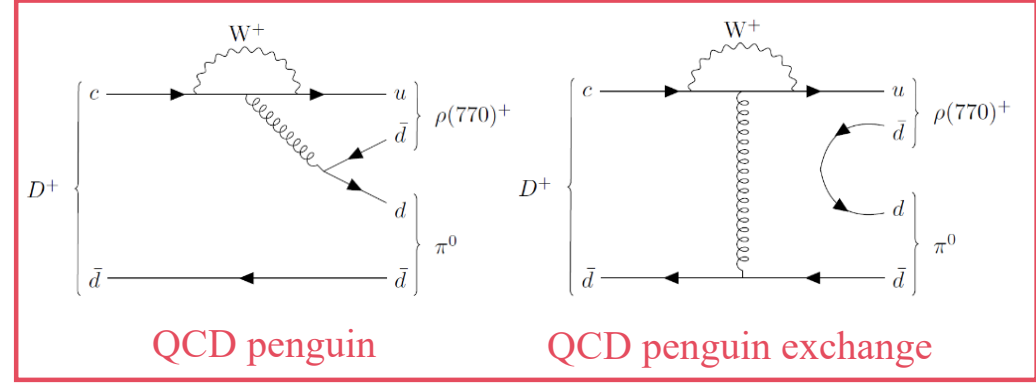
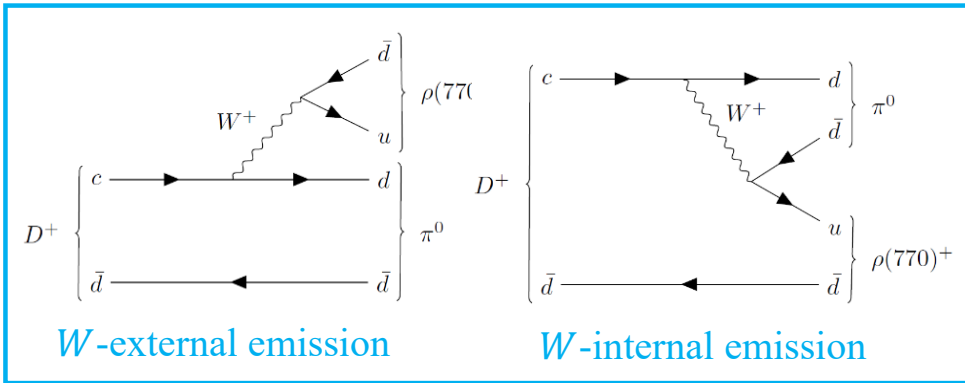
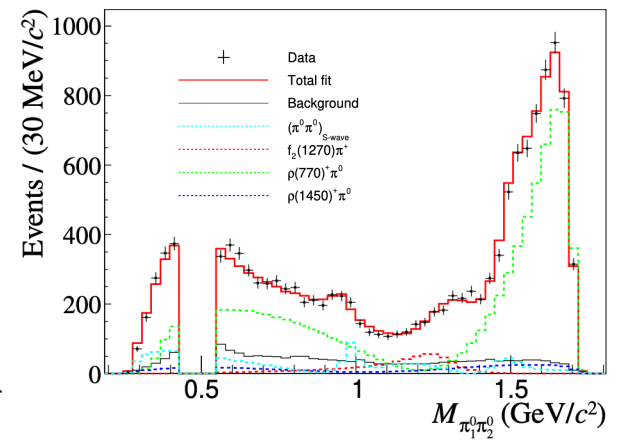
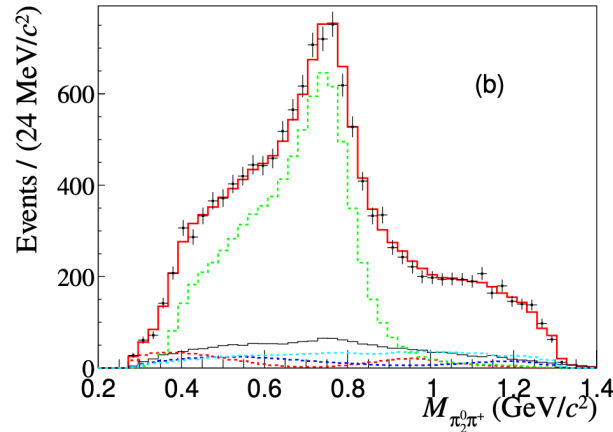
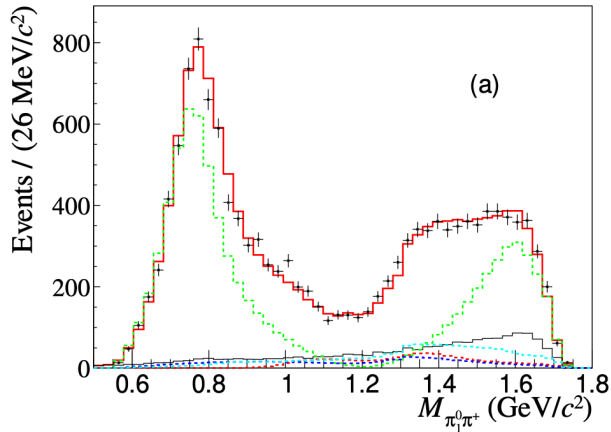

Recall measurements of $D^0 \rightarrow \pi^+ \pi^-$
and $B^+ \rightarrow \pi^+ \pi^- \pi^+$ by LHCb

Testing CP violation

Decay mode	D^+ (%)	D^- (%)	\mathcal{A}_{FF} (%)
$D^{+(-)} \rightarrow \rho(770)^{+(-)} \pi^0$	$64.3 \pm 2.3 \pm 0.9$	$63.2 \pm 2.1 \pm 0.6$	$0.9 \pm 1.8 \pm 0.6$
$D^{+(-)} \rightarrow \rho(1450)^{+(-)} \pi^0$	$4.9 \pm 0.8 \pm 0.8$	$5.6 \pm 0.8 \pm 0.8$	$-7.2 \pm 6.8 \pm 6.8$
$D^{+(-)} \rightarrow f_2(1270) \pi^{+(-)}$	$4.3 \pm 0.4 \pm 0.2$	$4.7 \pm 0.4 \pm 0.2$	$-5.0 \pm 5.7 \pm 2.7$
$D^{+(-)} \rightarrow (\pi^0 \pi^0)_{S\text{-wave}} \pi^{+(-)}$	$11.6 \pm 0.9 \pm 0.5$	$11.4 \pm 0.9 \pm 0.5$	$0.8 \pm 1.8 \pm 1.1$

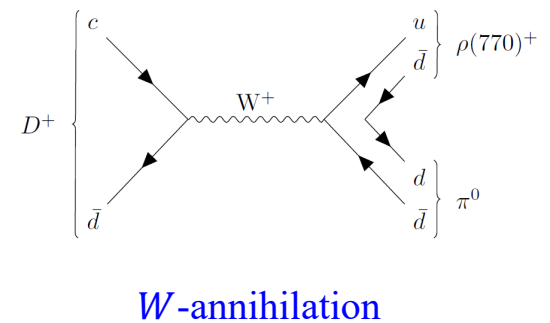

Amplitude analysis of $D_S^+ \rightarrow \pi^+ \pi^0 \eta$

- Observation of $D_S^+ \rightarrow a_0(980)\pi$

PRL123, 112001 (2019)

$D_S^+ \rightarrow \pi^+ \pi^0 \eta$ **Full sample**

Sub-sample with $M_{\pi^+ \pi^0} > 1.0 \text{ GeV}/c^2$

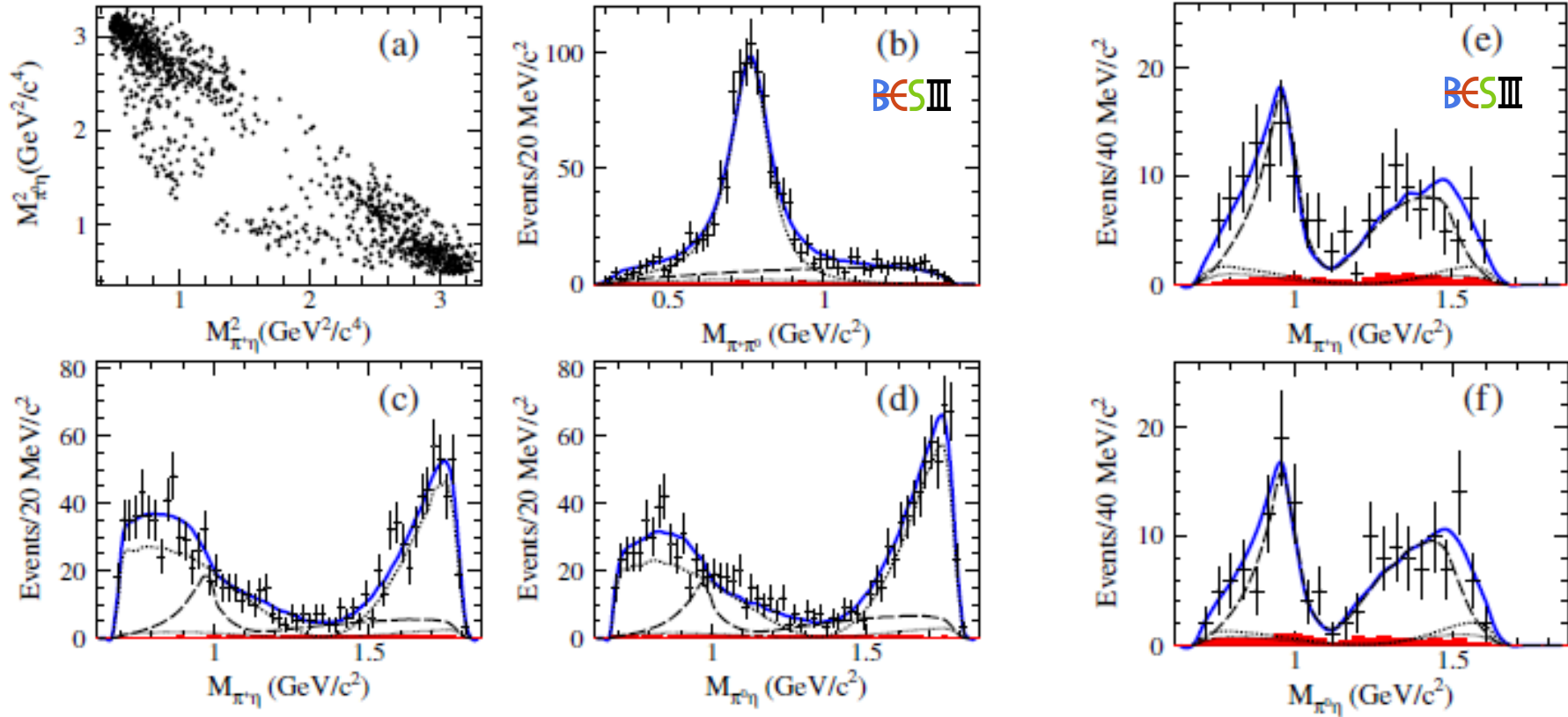

Dots with error bar: data; solid: total fit; dotted: $D_S^+ \rightarrow \rho^+ \eta$; dashed: $D_S^+ \rightarrow a_0(980)\pi$ (**with a stat. significance of 16.2σ**).

Branching Fraction Results of $D_s^+ \rightarrow \pi^+ \pi^0 \eta$

PRL123, 112001 (2019)

Fit to the invariant mass $M_{\pi^+ \pi^0 \eta}$ to get the yield.

$$\mathcal{B}(D_s^+ \rightarrow \pi^+ \pi^0 \eta) = (9.50 \pm 0.28_{stat.} \pm 0.41_{syst.})\%$$

$$\text{PDG value} = (9.2 \pm 1.2)\%$$

$$\text{BF}(\text{sub-mode } n) = \mathcal{B}(D_s^+ \rightarrow \pi^+ \pi^0 \eta) FF(n)$$

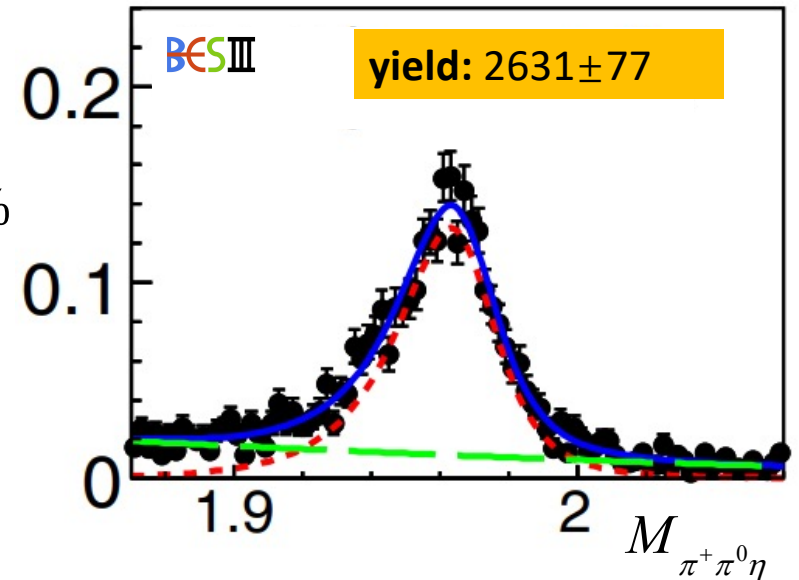

$$\text{PDG value} = (8.9 \pm 0.9)\%$$

First observation !

Branching fraction (%)	BESIII
$\mathcal{B}(D_s^+ \rightarrow \rho^+ \eta)$	$7.44 \pm 0.52_{stat.} \pm 0.38_{sys.}$
$\mathcal{B}(D_s^+ \rightarrow a_0(980)^+ \pi^0)^*$	$1.46 \pm 0.15_{stat.} \pm 0.23_{sys.}$
$\mathcal{B}(D_s^+ \rightarrow a_0(980)^0 \pi^+)^*$	$1.46 \pm 0.15_{stat.} \pm 0.23_{sys.}$

*here, $a_0(980) \rightarrow \pi \eta$

- $\mathcal{B}(D_s^+ \rightarrow a_0(980)^+ \pi^0)$ is larger than other measured pure W -annihilation decays ($D_s^+ \rightarrow p \bar{n}$, $D_s^+ \rightarrow \omega \pi^+$) **by one order**.

Observation of $D \rightarrow a_0(980)\pi$

Phys. Rev. D 110, L111102 (2024)

$D^0 \rightarrow \pi^+\pi^-\eta$

$7.9\text{fb}^{-1}@E_{cm}=3.773\text{ GeV}$

$D^+ \rightarrow \pi^+\pi^0\eta$

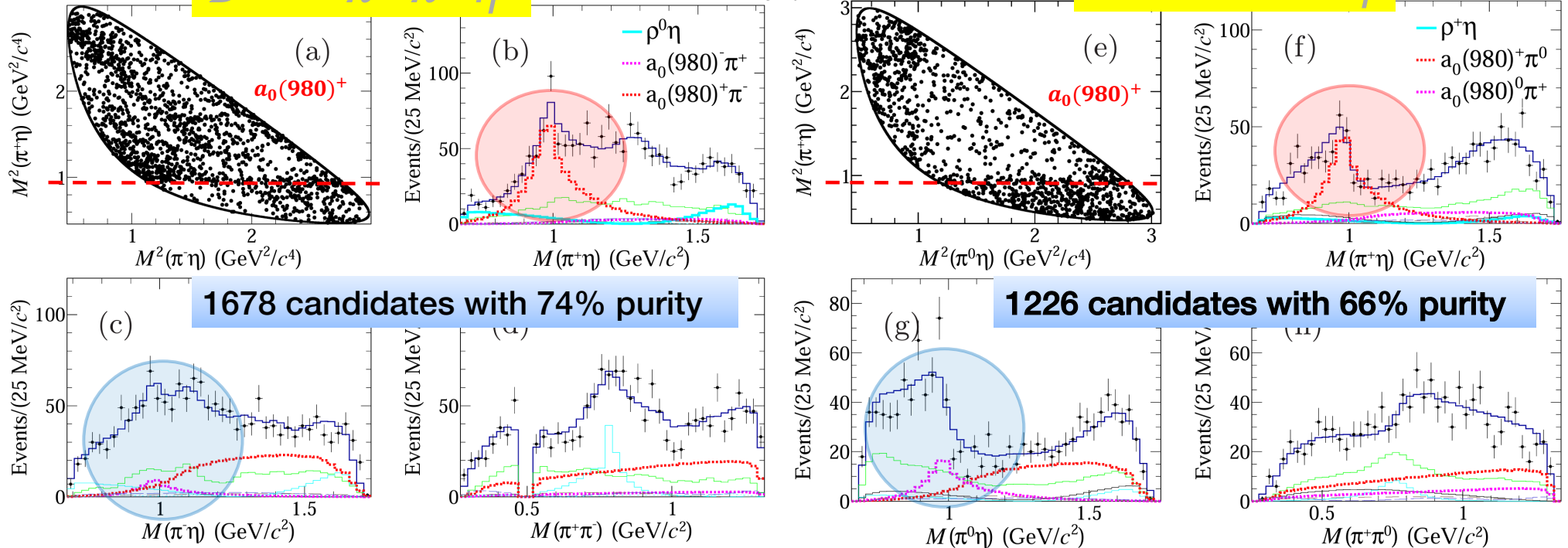

$$\mathcal{B}(D^0 \rightarrow a_0(980)^+\pi^-)/\mathcal{B}(D^0 \rightarrow a_0(980)^-\pi^+) = 7.5^{+2.5}_{-0.8_{\text{stat}}} \pm 1.7_{\text{syst.}}$$

$$\mathcal{B}(D^+ \rightarrow a_0(980)^+\pi^0)/\mathcal{B}(D^+ \rightarrow a_0(980)^0\pi^+) = 2.6 \pm 0.6_{\text{stat.}} \pm 0.3_{\text{syst.}}$$

\Rightarrow Disagrees with theoretical predictions by orders of magnitude in diquark model

The external W-emission diagram dominates the $D \rightarrow a_0(980)\pi$ decays in the diquark scenario, contrary to expectations of its negligible contribution due to the very small $a_0(980)$ decay constant[1].

[1] Phys. Rev. D 110, 094052(2024).

More discussion for $D \rightarrow a_0(980)\pi$

In 2-quark scenario,

Phys. Rev. D 105, 033006(2022) by H. Y. Cheng et al.

$$D^0 \rightarrow a_0^+ \pi^-$$

$$\rightarrow a_0^- \pi^+$$

$$V_{cd}^* V_{ud}(T' + E)$$

$$V_{cd}^* V_{ud}(T + E')$$

$$|T'| \ll |T|$$

In tetraquark scenario,

Phys. Rev. D 110, 094052(2024) by H. Y. Cheng et al.

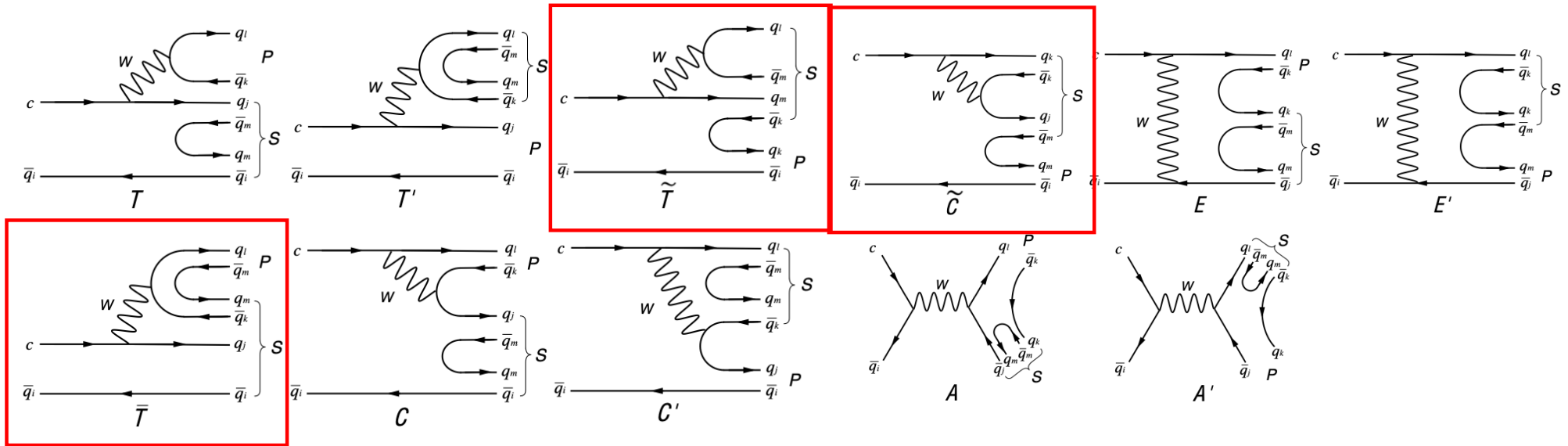

In the 2-quark model the diagrams \bar{T} , \tilde{T} and \tilde{C} are absent

Amplitude analysis of $D_S^+ \rightarrow \pi^+ \pi^+ \pi^- \eta$

PRD 104, L071101 (2021)

2139 events with purity > 85%

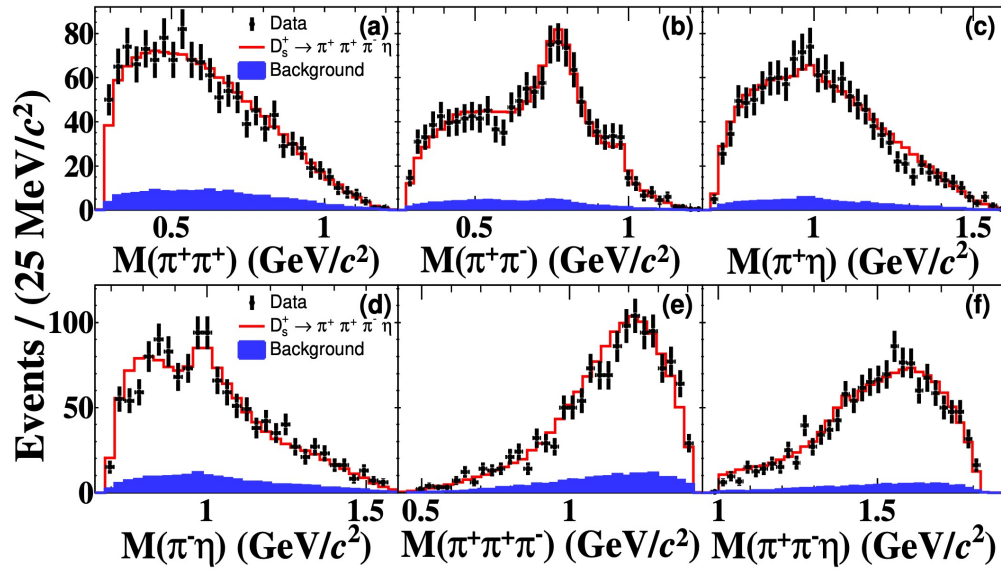

$$\mathcal{B}(D_S^+ \rightarrow \pi^+ \pi^+ \pi^- \eta) = (3.12 \pm 0.13 \pm 0.09)\%$$

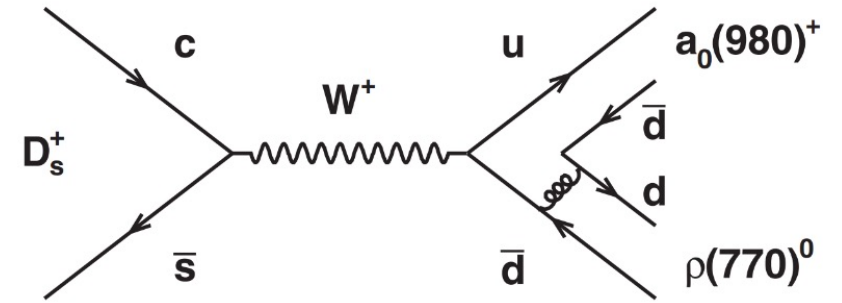

$$\mathcal{B}(D_S^+ \rightarrow a_0^+(980)\rho^0, a_0^+(980) \rightarrow \pi^+\eta) = (0.21 \pm 0.08 \pm 0.05)\%$$

Amplitude	Phase	FF(%)
$a_1(1260)^+(\rho(770)^0\pi^+)\eta$	0.0(fixed)	$55.4 \pm 3.9 \pm 2.0$
$a_1(1260)^+(f_0(500)\pi^+)\eta$	$5.0 \pm 0.1 \pm 0.1$	$8.1 \pm 1.9 \pm 2.1$
$a_0(980)^+\rho(770)^0$	$2.5 \pm 0.1 \pm 0.1$	$6.7 \pm 2.5 \pm 1.5$
$\eta(1405)(a_0(980)^-\pi^+)\pi^+$	$0.2 \pm 0.2 \pm 0.1$	$0.7 \pm 0.2 \pm 0.1$
$\eta(1405)(a_0(980)^+\pi^-)\pi^+$	$0.2 \pm 0.2 \pm 0.1$	$0.7 \pm 0.2 \pm 0.1$
$f_1(1420)(a_0(980)^-\pi^+)\pi^+$	$4.3 \pm 0.2 \pm 0.4$	$1.9 \pm 0.5 \pm 0.3$
$f_1(1420)(a_0(980)^+\pi^-)\pi^+$	$4.3 \pm 0.2 \pm 0.4$	$1.7 \pm 0.5 \pm 0.3$
$[a_0(980)^-\pi^+]_S\pi^+$	$0.1 \pm 0.2 \pm 0.2$	$5.1 \pm 1.2 \pm 0.9$
$[a_0(980)^+\pi^-]_S\pi^+$	$0.1 \pm 0.2 \pm 0.2$	$3.4 \pm 0.8 \pm 0.6$
$[f_0(980)\eta]_S\pi^+$	$1.4 \pm 0.2 \pm 0.3$	$6.2 \pm 1.7 \pm 0.9$
$[f_0(500)\eta]_S\pi^+$	$2.5 \pm 0.2 \pm 0.3$	$12.7 \pm 2.6 \pm 2.0$

Larger than other w-annihilation decays.

How about $D_S^+ \rightarrow a_0^+(980)\rho^0$? Does it have the same branching fraction?

Amplitude analysis of $D_s^+ \rightarrow \pi^+ \pi^0 \pi^0 \eta$

arXiv 2603.18521

$$\mathcal{B}(D_s^+ \rightarrow \pi^+ \pi^0 \pi^0 \eta) = (2.97 \pm 0.23 \pm 0.14)\%$$

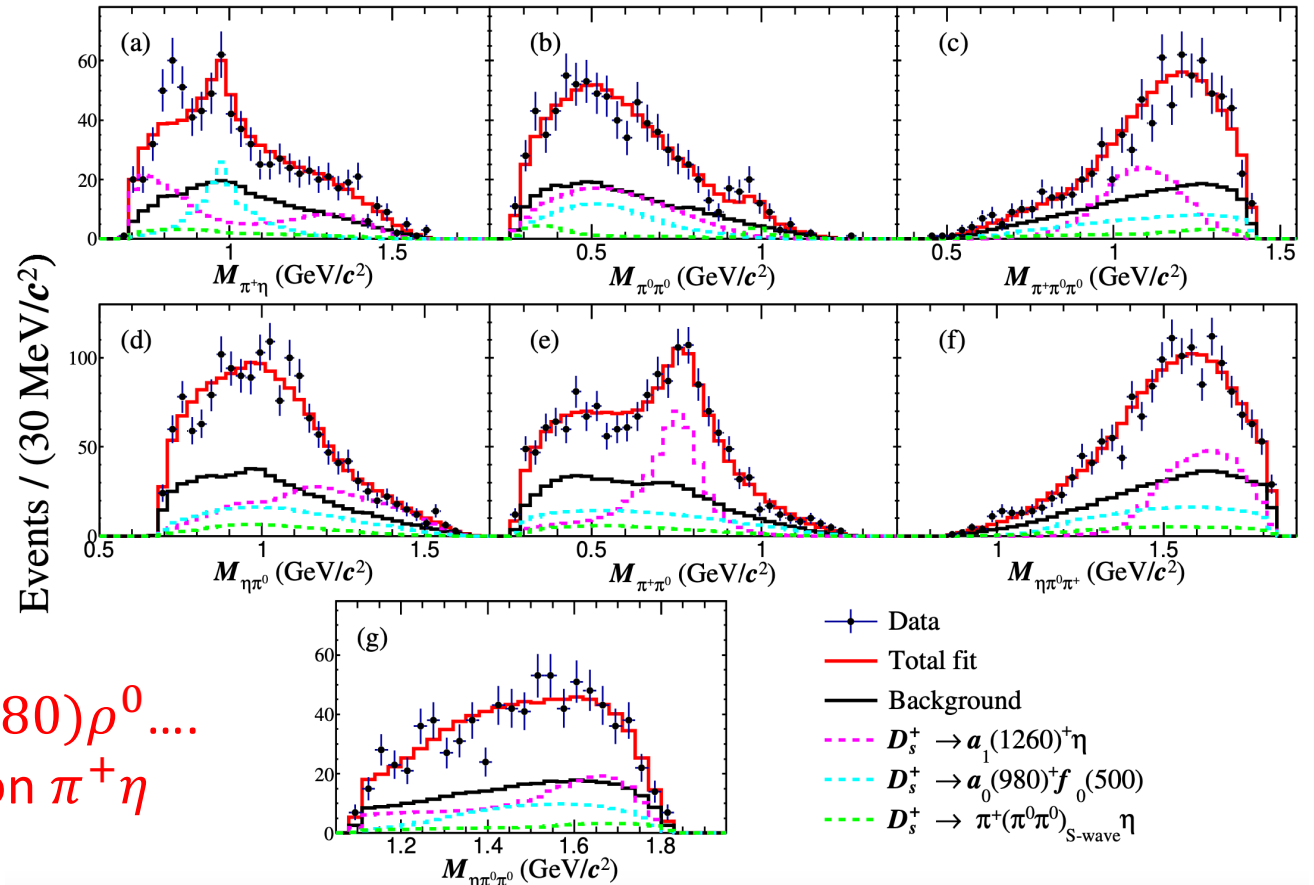

Not observe $D_s^+ \rightarrow a_0^+(980)\rho^0 \dots$
But an interesting peak on $\pi^+ \eta$

Amplitude	Phase (rad)	FF (%)	BF (%)	Significance
$D_s^+ \rightarrow a_1(1260)^+ \eta, a_1(1260)^+ \rightarrow \rho(770)^+ \pi^0$	0.0 (fixed)	$59.7 \pm 5.2 \pm 2.9$	$1.77 \pm 0.21 \pm 0.12$	$> 10\sigma$
$D_s^+ \rightarrow a_0(980)^+ f_0(500)$	$2.8 \pm 0.2 \pm 0.3$	$33.1 \pm 4.9 \pm 6.8$	$0.98 \pm 0.16 \pm 0.22$	$> 10\sigma$
$D_s^+ \rightarrow \pi^+(\pi^0 \pi^0)_{S\text{-wave}} \eta$	$-0.8 \pm 0.2 \pm 0.3$	$9.4 \pm 1.9 \pm 4.1$	$0.28 \pm 0.06 \pm 0.13$	4.5σ

Dominated by $a_1^+(1260)\eta$ and observe $D_s \rightarrow SS$

Amplitude analysis of $D^+ \rightarrow \pi^+ \pi^+ \pi^- \eta$

arXiv 2604.10444

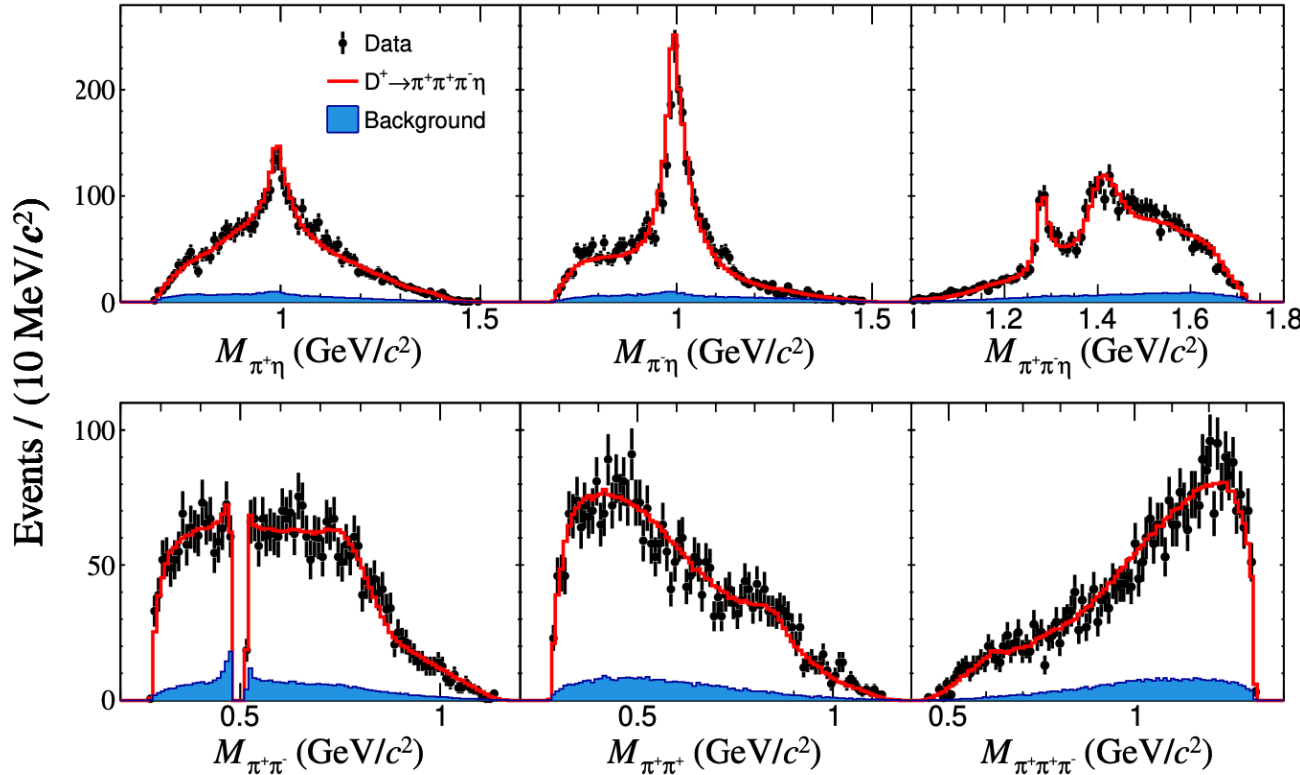

$$\frac{\mathcal{B}(D^+ \rightarrow a_0(980)^+ \rho(770)^0)}{\mathcal{B}(D^+ \rightarrow a_0(980)^0 \rho(770)^+)} = 0.55 \pm 0.08_{\text{stat.}} \pm 0.05_{\text{syst.}}$$

$$\mathcal{B}(D^+ \rightarrow \pi^+ \pi^+ \pi^- \eta |_{\text{non-}\eta'}) = (3.20 \pm 0.06_{\text{stat.}} \pm 0.03_{\text{syst.}}) \times 10^{-3}$$

Amplitude	ϕ	FF(%)	Significance (σ)	BF($\times 10^{-4}$)
$D^+ \rightarrow \pi^+ \pi^+ \pi^- \eta$ decay:				
$D^+ \rightarrow a_0(980)^+ \rho(770)^0$	0 (fixed)	$14.7 \pm 1.1 \pm 1.0$	First observation	$4.7 \pm 0.4 \pm 0.3$
$D^+ \rightarrow a_0(980)^+ f_0(500)$	$5.5 \pm 0.1 \pm 0.2$	$23.2 \pm 2.3 \pm 2.2$	> 10	$7.5 \pm 0.7 \pm 0.7$
$D^+ \rightarrow \eta(1405)\pi^+$	$2.4 \pm 0.1 \pm 0.1$	$11.2 \pm 1.4 \pm 1.5$	> 10	$3.6 \pm 0.5 \pm 0.5$
$D^+ \rightarrow f_1(1285)\pi^+$	$4.9 \pm 0.1 \pm 0.3$	$17.3 \pm 0.9 \pm 0.8$	> 10	$5.5 \pm 0.3 \pm 0.3$
$D^+ \rightarrow f_1(1420)\pi^+$	$6.2 \pm 0.1 \pm 0.1$	$16.4 \pm 1.6 \pm 2.5$	> 10	$5.2 \pm 0.5 \pm 0.8$
$D^+ \rightarrow [a_0(980)^\pm \pi^\mp]_{S\text{-wave}} \pi^+$	$3.5 \pm 0.1 \pm 0.3$	$34.3 \pm 2.8 \pm 3.2$	> 10	$11.0 \pm 0.9 \pm 1.0$

Amplitude analysis of $D^+ \rightarrow \pi^+ \pi^0 \pi^0 \eta$ arXiv 2604.10444

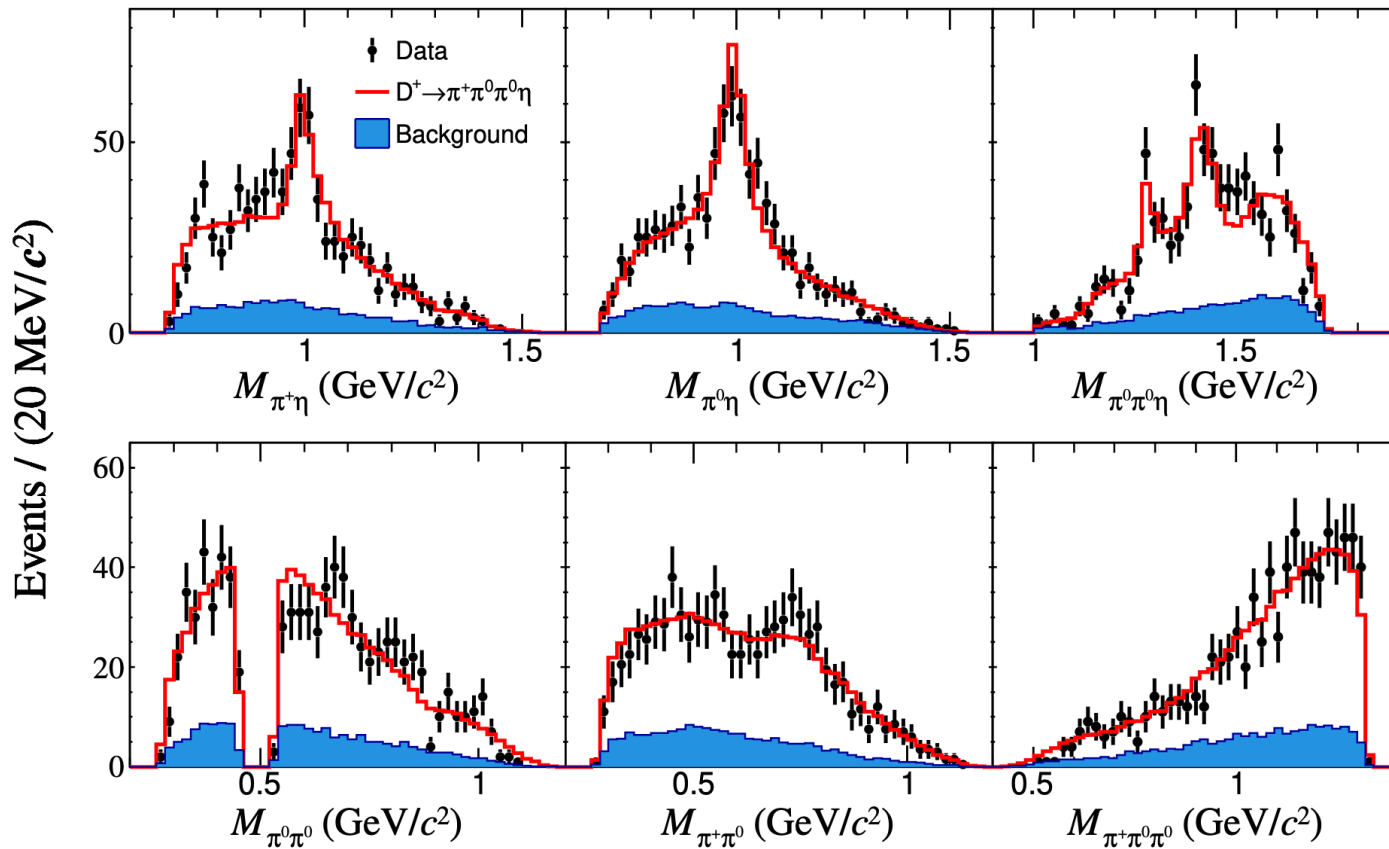

$$\mathcal{B}(D^+ \rightarrow \pi^+ \pi^0 \pi^0 \eta |_{\text{non-}\eta'}) = (2.43 \pm 0.11_{\text{stat.}} \pm 0.04_{\text{syst.}}) \times 10^{-3}$$

$D^+ \rightarrow \pi^+ \pi^0 \pi^0 \eta$ decay:

$D^+ \rightarrow a_0(980)^0 \rho(770)^+$	0 (fixed)	$35.0 \pm 3.5 \pm 2.6$	First observation	$8.5 \pm 0.9 \pm 0.6$
$D^+ \rightarrow a_0(980)^+ f_0(500)$	$0.4 \pm 0.1 \pm 0.0$	$34.6 \pm 3.1 \pm 1.0$	> 10	$8.4 \pm 0.8 \pm 0.3$
$D^+ \rightarrow \eta(1405) \pi^+$	$2.6 \pm 0.3 \pm 0.2$	$4.3 \pm 1.7 \pm 0.7$	5.1	$1.0 \pm 0.4 \pm 0.2$
$D^+ \rightarrow f_1(1285) \pi^+$	$2.9 \pm 0.2 \pm 0.3$	$12.8 \pm 1.9 \pm 0.7$	> 10	$3.1 \pm 0.5 \pm 0.2$
$D^+ \rightarrow f_1(1420) \pi^+$	$5.9 \pm 0.2 \pm 0.3$	$17.8 \pm 3.0 \pm 1.6$	> 10	$4.3 \pm 0.8 \pm 0.4$
$D^+ \rightarrow [a_0(980)^0 \pi^0]_{S\text{-wave}} \pi^+$	$4.4 \pm 0.2 \pm 0.2$	$11.0 \pm 2.6 \pm 0.9$	8.6	$2.7 \pm 0.6 \pm 0.2$

Amplitude analysis of $D_s^+ \rightarrow K^+ K^- \pi^+$

The best precision for Golden mode $D_s^+ \rightarrow \phi \pi^+$

Process	BF (%)	PDG 2024
$D_s^+ \rightarrow \bar{K}^*(892)^0 K^+, \bar{K}^*(892)^0 \rightarrow K^- \pi^+$	$2.64 \pm 0.06_{\text{stat}} \pm 0.07_{\text{sys}}$	2.58 ± 0.06
$D_s^+ \rightarrow \phi(1020) \pi^+, \phi(1020) \rightarrow K^+ K^-$	$2.21 \pm 0.05_{\text{stat}} \pm 0.07_{\text{sys}}$	2.21 ± 0.06
$D_s^+ \rightarrow S(980) \pi^+, S(980) \rightarrow K^+ K^-$	$1.05 \pm 0.04_{\text{stat}} \pm 0.06_{\text{sys}}$	1.11 ± 0.19
$D_s^+ \rightarrow \bar{K}_0^*(1430)^0 K^+, \bar{K}_0^*(1430)^0 \rightarrow K^- \pi^+$	$0.16 \pm 0.03_{\text{stat}} \pm 0.03_{\text{sys}}$	0.18 ± 0.03
$D_s^+ \rightarrow f_0(1710) \pi^+, f_0(1710) \rightarrow K^+ K^-$	$0.10 \pm 0.02_{\text{stat}} \pm 0.03_{\text{sys}}$	0.07 ± 0.03
$D_s^+ \rightarrow f_0(1370) \pi^+, f_0(1370) \rightarrow K^+ K^-$	$0.07 \pm 0.02_{\text{stat}} \pm 0.01_{\text{sys}}$	0.07 ± 0.03
$D_s^+ \rightarrow K^+ K^- \pi^+$ total BF	$5.47 \pm 0.08_{\text{stat}} \pm 0.13_{\text{sys}}$	5.37 ± 0.10

PRD 104. 012016 (2021)

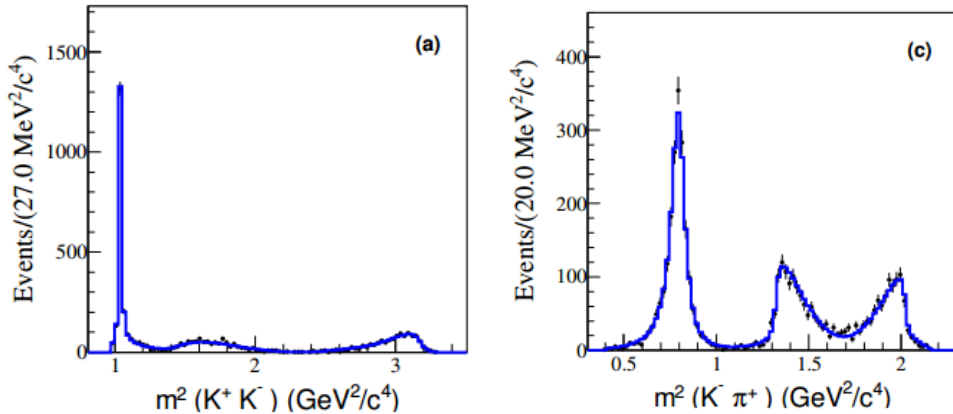

Both $a_0(980)$ and $f_0(980)$ decays to $K^+ K^-$. Impossible to separate them here

Isospin configurations:

$$a_0(980) \ I=1 \rightarrow (|K^+ K^- \rangle - |K^0 \bar{K}^0 \rangle)$$

$$f_0(980) \ I=0 \rightarrow (|K^+ K^- \rangle + |K^0 \bar{K}^0 \rangle)$$

The comparison of $K^+ K^-$ and $K_S^0 K_S^0$ spectrum will reveal more information!

Amplitude analysis of $D_s^+ \rightarrow K_S^0 K_S^0 \pi^+$

PRD 105, L051103

- Observation of interference between scalar mesons

412 events with purity of $(97.3 \pm 0.8)\%$.

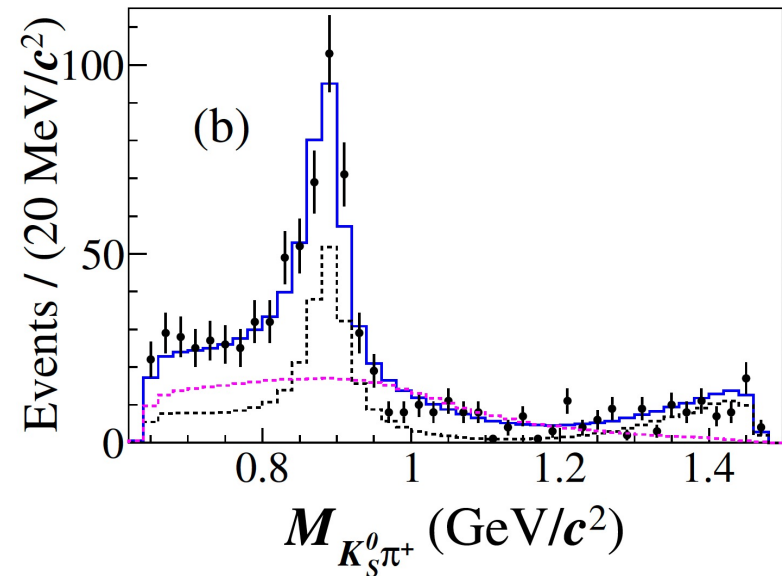
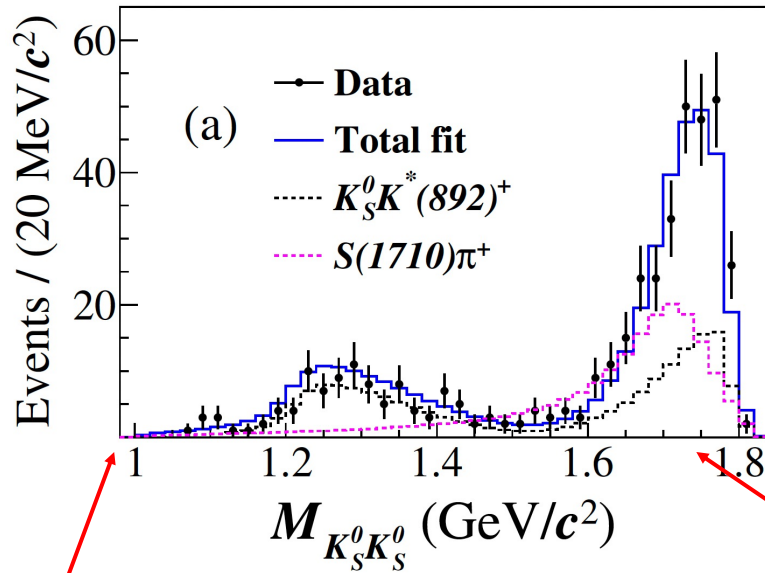

destructive interference: $a_0(980)$ and $f_0(980)$

abnormal enhancement at $f_0(1710)$

$$\mathcal{B}(D_s^+ \rightarrow K_S^0 K_S^0 \pi^+) = (0.68 \pm 0.04_{stat.} \pm 0.01_{syst.})\%$$

Amplitude	BF (10^{-3})
$D_s^+ \rightarrow K_S^0 K^*(892)^+ \rightarrow K_S^0 K_S^0 \pi^+$	$3.0 \pm 0.3 \pm 0.1$
$D_s^+ \rightarrow S(1710)\pi^+ \rightarrow K_S^0 K_S^0 \pi^+$	$3.1 \pm 0.3 \pm 0.1$

Observation of new a_0 -like triplet in D_s decays



PRD 105, L051103

- [1] Eur. Phys. J. C 82, 225 (2022).
 [2] Phys.Rev. D105, 114014 (2022).
 [3] PRD 104, 072002 (2021)

constructive interference: new neutral a_0 -like and $f_0(1710)$

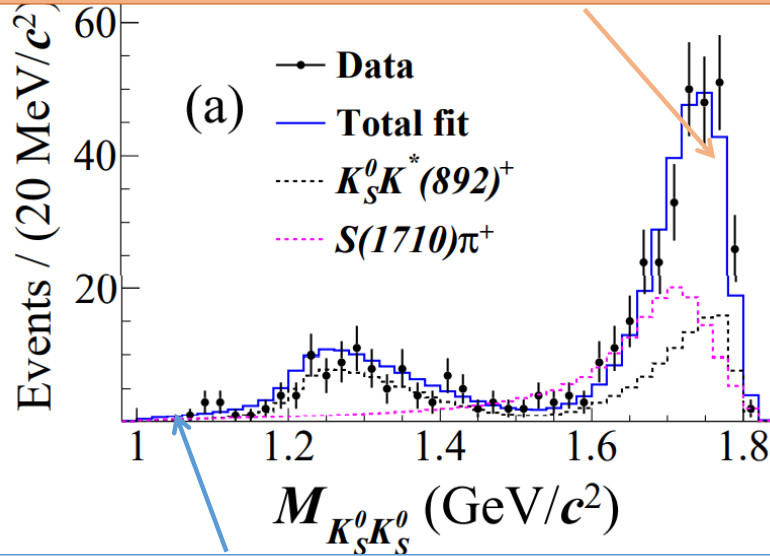

destructive interference: $a_0(980)$ and $f_0(980)$



PRL 129, 182001

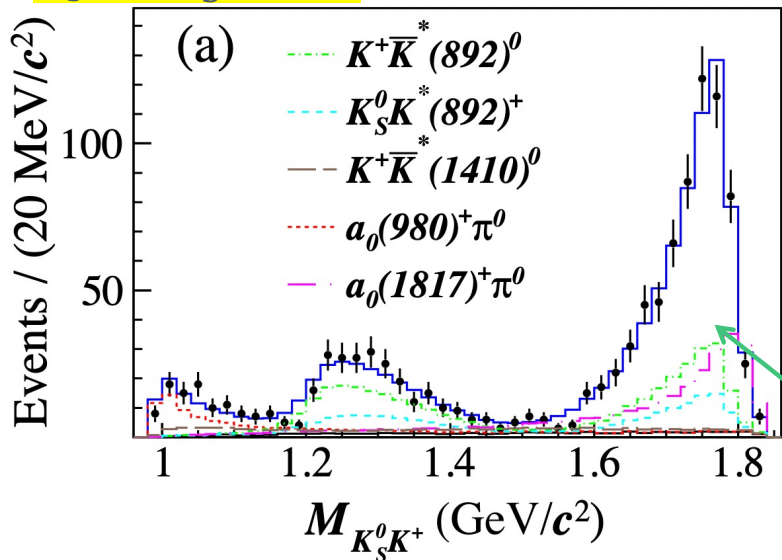

A new a_0 isospin triplet!

Amplitude	BF (10^{-3})
$D_s^+ \rightarrow \bar{K}^*(892)^0 K^+$	$4.77 \pm 0.38 \pm 0.32$
$D_s^+ \rightarrow K^*(892)^+ K_S^0$	$2.03 \pm 0.26 \pm 0.20$
$D_s^+ \rightarrow a_0(980)^+ \pi^0$	$1.12 \pm 0.25 \pm 0.27$
$D_s^+ \rightarrow \bar{K}^*(1410)^0 K^+$	$0.88 \pm 0.21 \pm 0.19$
$D_s^+ \rightarrow a_0(1817)^+ \pi^0$	$3.44 \pm 0.52 \pm 0.32$

- Double tag method
- $D_s^+ \rightarrow a_0(1817)^+ \pi^0$ is observed for the first time
- Significance $> 10\sigma$
- $M = 1.817 \pm 0.008 \pm 0.020 \text{ GeV}/c^2$
- $\Gamma = 0.097 \pm 0.022 \pm 0.015 \text{ GeV}/c^2$
- The isovector partner of $f_0(1710)$ [1] or $X(1812)$?[2]
- Same resonance observed in η_c to $\pi\pi\eta$ by BaBar[3]?

new charged a_0 -like in $K_S^0 K^+$ mass spectrum

Study of $D^+ \rightarrow K_S^0 a_0(980)^+$

PRL 132, 131903 (2024)

Among $D \rightarrow SP$, $D^+ \rightarrow K_S^0 a_0(980)^+$ is, except $\kappa\pi$, the only decay free of weak-annihilation contributions.

2.93fb⁻¹@ $E_{cm}=3.773$ GeV
1113 candidates with 98.2% purity

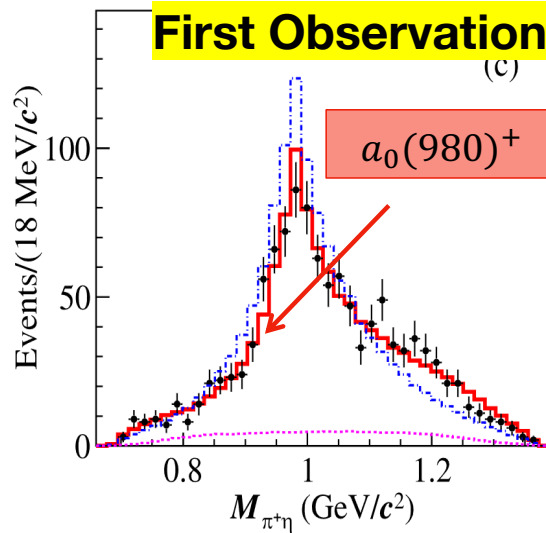

two-quark
internal W-emission

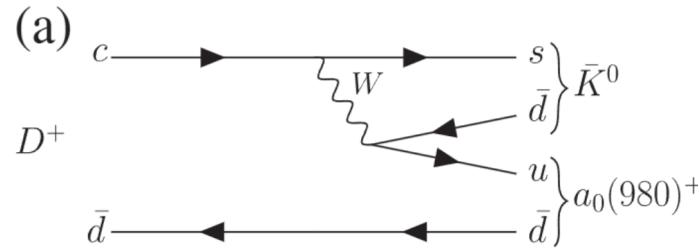

tetraquark state-
rescattering

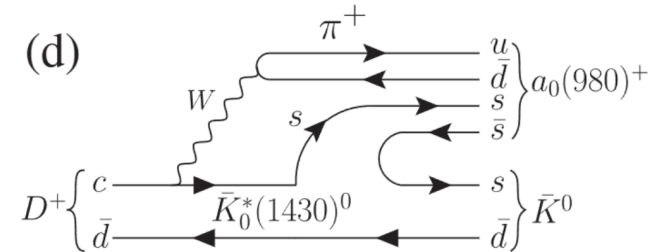

$$\mathcal{B}(D^+ \rightarrow K_S^0 \pi^+ \eta) = (1.27 \pm 0.04_{stat} \pm 0.03_{syst})\%$$

- $\mathcal{B}(D^+ \rightarrow K_S^0 a_0(980)^+, a_0(980)^+ \rightarrow \pi^+ \eta) = (1.33 \pm 0.05_{stat} \pm 0.04_{syst})\%$
- **Provide sensitive constraints in the extraction of contributions from external and internal W-emission diagrams of $D \rightarrow SP$**
- Understand the inconsistency between theory and experiment of the $D \rightarrow a_0(980)^+ P$ [1-3].

[1] Phys. Rev. D 105, 033006 (2022).
[2] Phys. Rev. D 67, 034024 (2003).
[3] Phys. Rev. D 81, 074031 (2010)

Amplitude analysis of $D^0 \rightarrow K_S^0 \pi^0 \eta$

☉ $D^0 \rightarrow \eta \bar{K}^*(892)^0$

arXiv:2512.23389

Impacts predictions from the topological diagram approach, affecting CP violation and DCS branching fraction estimates.

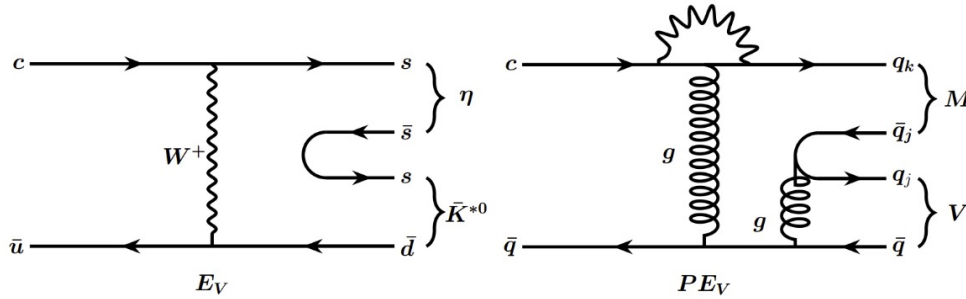

The BF determines the magnitude of E_V

E_V determines the magnitude of the penguin diagram PE_V

PE_V affects predictions for DCS decays and CP violation calculations.

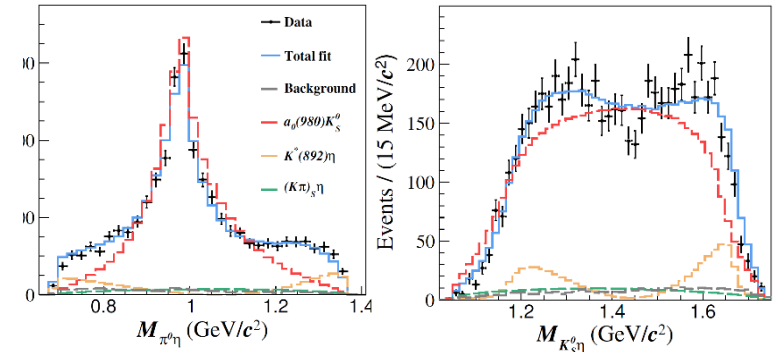
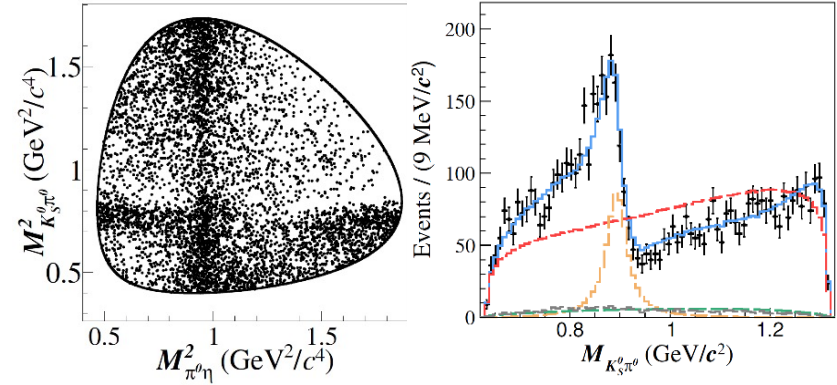

☉ $D^0 \rightarrow K_S^0 a_0(980)^0$

Source	Branching Fraction ($\times 10^{-3}$)	
	D^0 channel	D^+ channel
BESIII	$9.88 \pm 0.37 \pm 0.42$	$13.3 \pm 0.5 \pm 0.4$ [35]
$q\bar{q}$ model	0.55 [2]	6.5 [2]
Tetraquark	9.5-15.0 [2]	13.5 [2]

Favor prediction under tetraquark model

Amplitude	BF (10^{-3})
$D^0 \rightarrow K_S^0 a_0(980)^0, a_0(980)^0 \rightarrow \pi^0 \eta$	$9.88 \pm 0.37 \pm 0.42$
$D^0 \rightarrow K_S^0 a_2(1320)^0, a_2(1320)^0 \rightarrow \pi^0 \eta$	$0.08 \pm 0.11 \pm 0.11$
$D^0 \rightarrow \bar{K}^*(892)^0 \eta, \bar{K}^*(892)^0 \rightarrow K_S^0 \pi^0$	$1.22 \pm 0.09 \pm 0.11$
$D^0 \rightarrow \bar{K}^*(1410)^0 \eta, \bar{K}^*(1410)^0 \rightarrow K_S^0 \pi^0$	$0.56 \pm 0.14 \pm 0.16$
$D^0 \rightarrow (K_S^0 \pi^0)_{S\text{-wave}} \eta$	$0.64 \pm 0.10 \pm 0.10$
$D^0 \rightarrow \bar{K}^*(1680)^0 \pi^0, \bar{K}^*(1680)^0 \rightarrow K_S^0 \eta$	$0.19 \pm 0.07 \pm 0.05$
$D^0 \rightarrow \bar{K}_2^*(1980)^0 \pi^0, \bar{K}_2^*(1980)^0 \rightarrow K_S^0 \eta$	$0.45 \pm 0.15 \pm 0.16$

Helps determine the \bar{T} -diagram contribution

[2] Phys. Rev. D 110, 094052(2024) by H. Y. Cheng et al.

Study of $D_S^+ \rightarrow \phi(\pi^+\pi^-\pi^0, K^+K^-)\pi^+$

$D_S^+ \rightarrow \pi^+\pi^-\pi^0\pi^+$ Phys. Rev. Lett. 134,
011904 (2025)

First Measurement

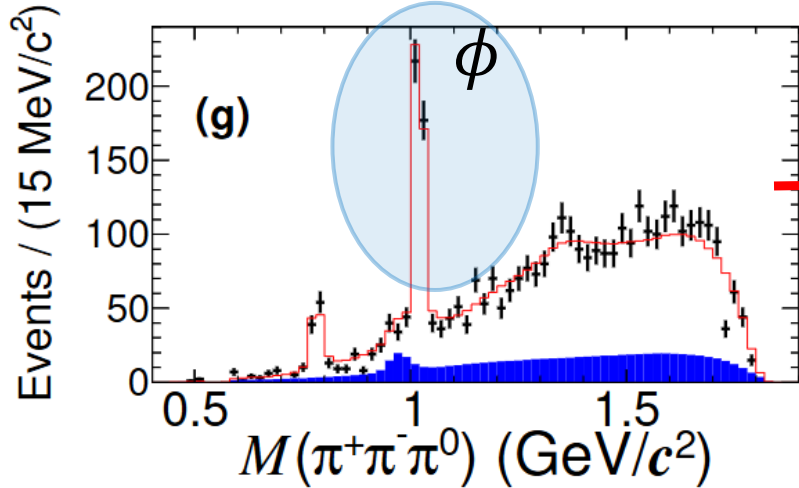

Component	Phase (rad)	FF (%)	BF (10^{-3})
$f_0(1370)\rho^+$	0.0(fixed)	$24.9 \pm 3.8 \pm 2.1$	$5.08 \pm 0.80 \pm 0.43$
$f_0(980)\rho^+$	$3.99 \pm 0.13 \pm 0.07$	$12.6 \pm 2.1 \pm 1.0$	$2.57 \pm 0.44 \pm 0.20$
$f_2(1270)\rho^+$	$1.11 \pm 0.10 \pm 0.10$	$9.5 \pm 1.7 \pm 0.6$	$1.94 \pm 0.36 \pm 0.12$
$(\rho^+\rho^0)_S$	$1.10 \pm 0.18 \pm 0.10$	$3.5 \pm 1.2 \pm 0.6$	$0.71 \pm 0.25 \pm 0.12$
$(\rho(1450)^+\rho^0)_S$	$0.43 \pm 0.18 \pm 0.17$	$4.6 \pm 1.3 \pm 0.8$	$0.94 \pm 0.27 \pm 0.16$
$(\rho^+\rho(1450)^0)_P$	$4.58 \pm 0.16 \pm 0.09$	$8.6 \pm 1.3 \pm 0.4$	$1.75 \pm 0.27 \pm 0.08$
$\phi((\rho\pi) \rightarrow \pi^+\pi^-\pi^0)\pi^+$	$2.90 \pm 0.15 \pm 0.18$	$24.9 \pm 1.2 \pm 0.4$	$5.08 \pm 0.32 \pm 0.10$
$\omega((\rho\pi) \rightarrow \pi^+\pi^-\pi^0)\pi^+$	$3.22 \pm 0.21 \pm 0.09$	$6.9 \pm 0.8 \pm 0.3$	$1.41 \pm 0.17 \pm 0.06$
$a_1^+(\rho^0\pi^+)_S\pi^0$	$3.78 \pm 0.16 \pm 0.12$	$12.5 \pm 1.6 \pm 1.0$	$2.55 \pm 0.34 \pm 0.20$
$a_1^0((\rho\pi)_S \rightarrow \pi^+\pi^-\pi^0)\pi^+$	$4.82 \pm 0.15 \pm 0.12$	$6.3 \pm 1.9 \pm 1.2$	$1.29 \pm 0.39 \pm 0.24$
$\pi(1300)^0((\rho\pi)_P \rightarrow \pi^+\pi^-\pi^0)\pi^+$	$2.22 \pm 0.14 \pm 0.08$	$11.7 \pm 2.3 \pm 2.2$	$2.39 \pm 0.48 \pm 0.45$

- $\mathcal{B}(D_S^+ \rightarrow \phi\pi^+, \phi \rightarrow \pi^+\pi^-\pi^0)$
 $= (5.08 \pm 0.32 \pm 0.10) \times 10^{-3}$
- $\mathcal{B}(D_S^+ \rightarrow \phi\pi^+, \phi \rightarrow K^+K^-)$
 $= (2.21 \pm 0.05 \pm 0.07)\%$

$D_S^+ \rightarrow K^+K^-\pi^+$ PRD 104, 012016

$$\frac{\mathcal{B}(\phi \rightarrow \pi^+\pi^-\pi^0)}{\mathcal{B}(\phi \rightarrow K^+K^-)} = 0.230 \pm 0.014 \pm 0.010$$

deviates from PDG 0.313 ± 0.010 by $> 4\sigma$.

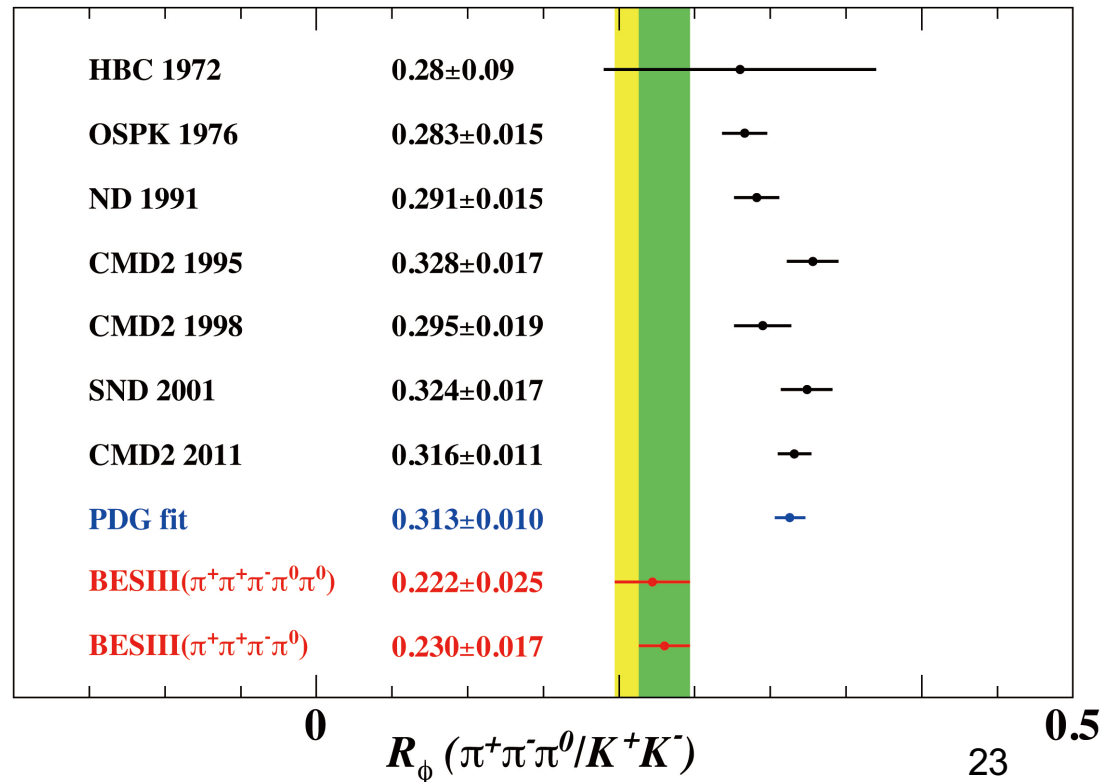

Amplitude analysis of $D_S^+ \rightarrow \phi(K_S^0 K_L^0)\pi^+$

$$D_S^+ \rightarrow K_S^0 K_L^0 \pi^+$$

Phys. Rev. Lett. 135, 161902 (2025)

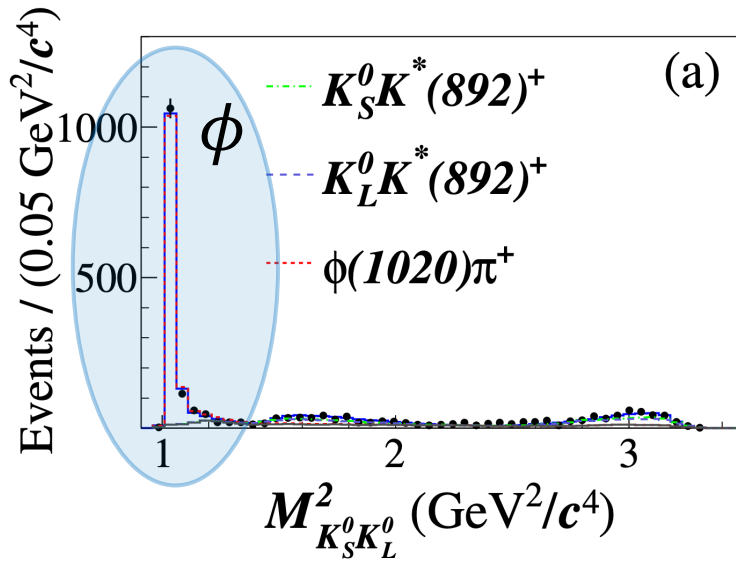

Amplitude	Phase (rad)	FF (%)	BF (%)
$D_S^+ \rightarrow \phi\pi^+$	0.0(fixed)	$70.9 \pm 1.3 \pm 1.5$	$1.32 \pm 0.05 \pm 0.04$
$D_S^+ \rightarrow K_L^0 K^*(892)^+$	$0.68 \pm 0.17 \pm 0.21$	$22.8 \pm 1.3 \pm 1.5$	$0.42 \pm 0.03 \pm 0.03$
$D_S^+ \rightarrow K_S^0 K^*(892)^+$	$-2.40 \pm 0.18 \pm 0.31$	$17.4 \pm 1.2 \pm 0.9$	$0.31 \pm 0.02 \pm 0.02$

✓ Measurement of ϕ

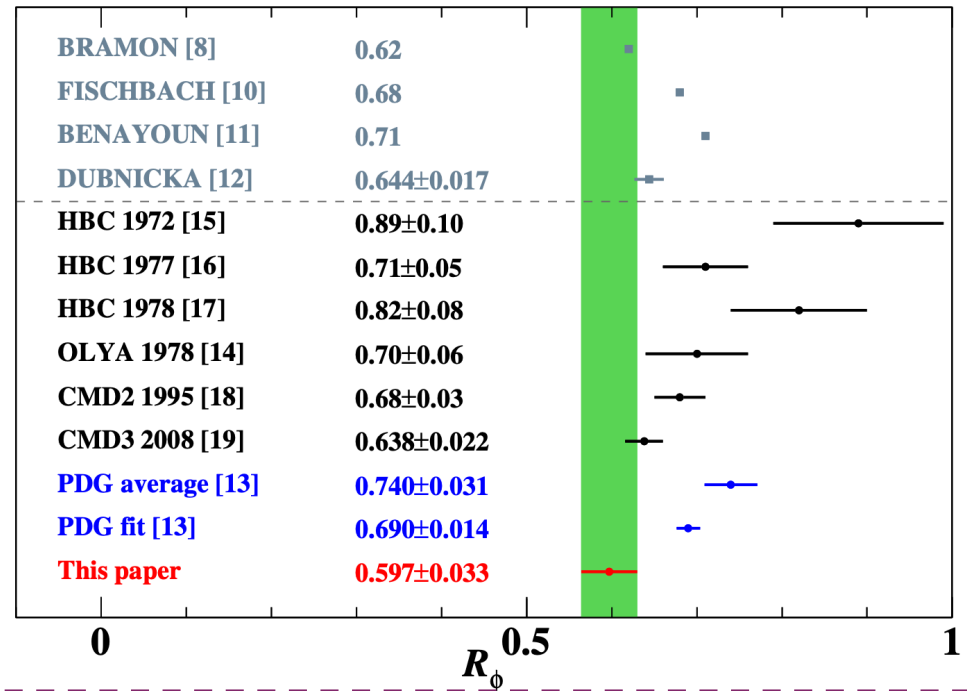

- ✓ Observation of the $K_S^0 - K_L^0$ asymmetry in the $D \rightarrow K_{S/L}^0 V$ (Interference of CF and DCS decays)

$$\frac{\mathcal{B}(D_S^+ \rightarrow K_S^0 K^*(892)^+) - \mathcal{B}(D_S^+ \rightarrow K_L^0 K^*(892)^+)}{\mathcal{B}(D_S^+ \rightarrow K_S^0 K^*(892)^+) + \mathcal{B}(D_S^+ \rightarrow K_L^0 K^*(892)^+)} = -0.134 \pm 0.05_{\text{stat.}} + 0.034_{\text{syst.}}$$

Model	DAT(F4)	DAT(F1')
$D_S^+ \rightarrow \bar{K}^0 K^{*+}$	-0.164 ± 0.032	-0.159 ± 0.028

Predictions by H. Y. Cheng *et al.*, PRD109, 073008

$$\frac{\mathcal{B}(\phi \rightarrow K_S^0 K_L^0)}{\mathcal{B}(\phi \rightarrow K^+ K^-)} = 0.597 \pm 0.023_{\text{stat}} \pm 0.024_{\text{syst}}$$

deviates from PDG (0.740 ± 0.033) by $> 3\sigma$. 24

Amplitude analysis of $D^+ \rightarrow \phi(K_S^0 K_L^0)\pi^+$

$$D^+ \rightarrow K_S^0 K_L^0 \pi^+$$

ArXiv: 2605.11464

Amplitude	Phase (rad)	FF (%)	BF (10^{-3})
$D^+ \rightarrow \phi\pi^+$	0.0(fixed)	$29.24 \pm 0.97 \pm 0.65$	$1.69 \pm 0.06 \pm 0.04$
$D^+ \rightarrow K_L^0 K^*(892)^+$	$2.34 \pm 0.09 \pm 0.09$	$40.21 \pm 0.83 \pm 0.26$	$2.33 \pm 0.06 \pm 0.03$
$D^+ \rightarrow K_S^0 K^*(892)^+$	$5.50 \pm 0.09 \pm 0.09$	$38.06 \pm 0.79 \pm 0.25$	$2.20 \pm 0.06 \pm 0.03$

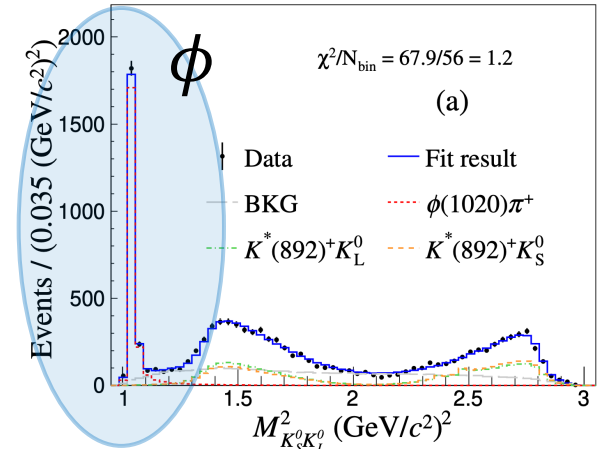

$$\frac{\mathcal{B}(\phi \rightarrow K_S^0 K_L^0)}{\mathcal{B}(\phi \rightarrow K^+ K^-)} = 0.611 \pm 0.023$$

Test isospin symmetry breaking with the $\phi \rightarrow K^+ K^-$ and $\phi \rightarrow K^0 \bar{K}^0$ couplings

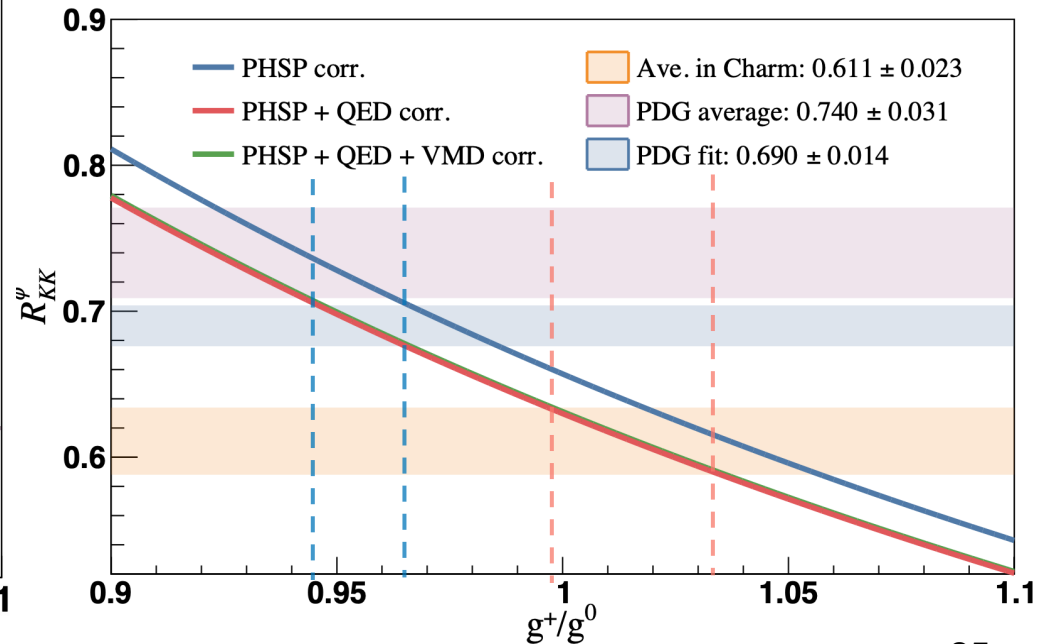
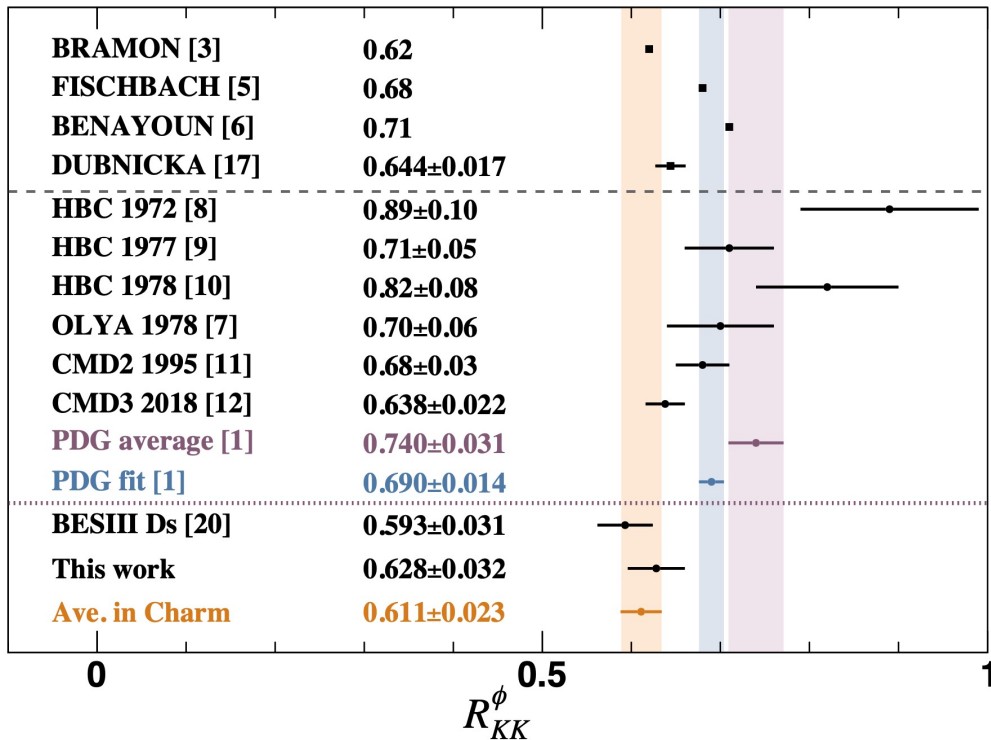

$D \rightarrow VV$ in $D_s^+ \rightarrow \pi^+ \pi^+ \pi^- \pi^0 \pi^0$

PRL 134, 201902 (2025)

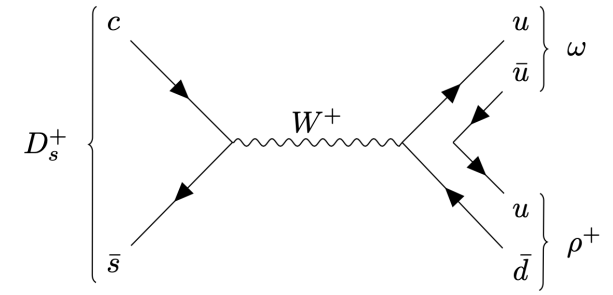
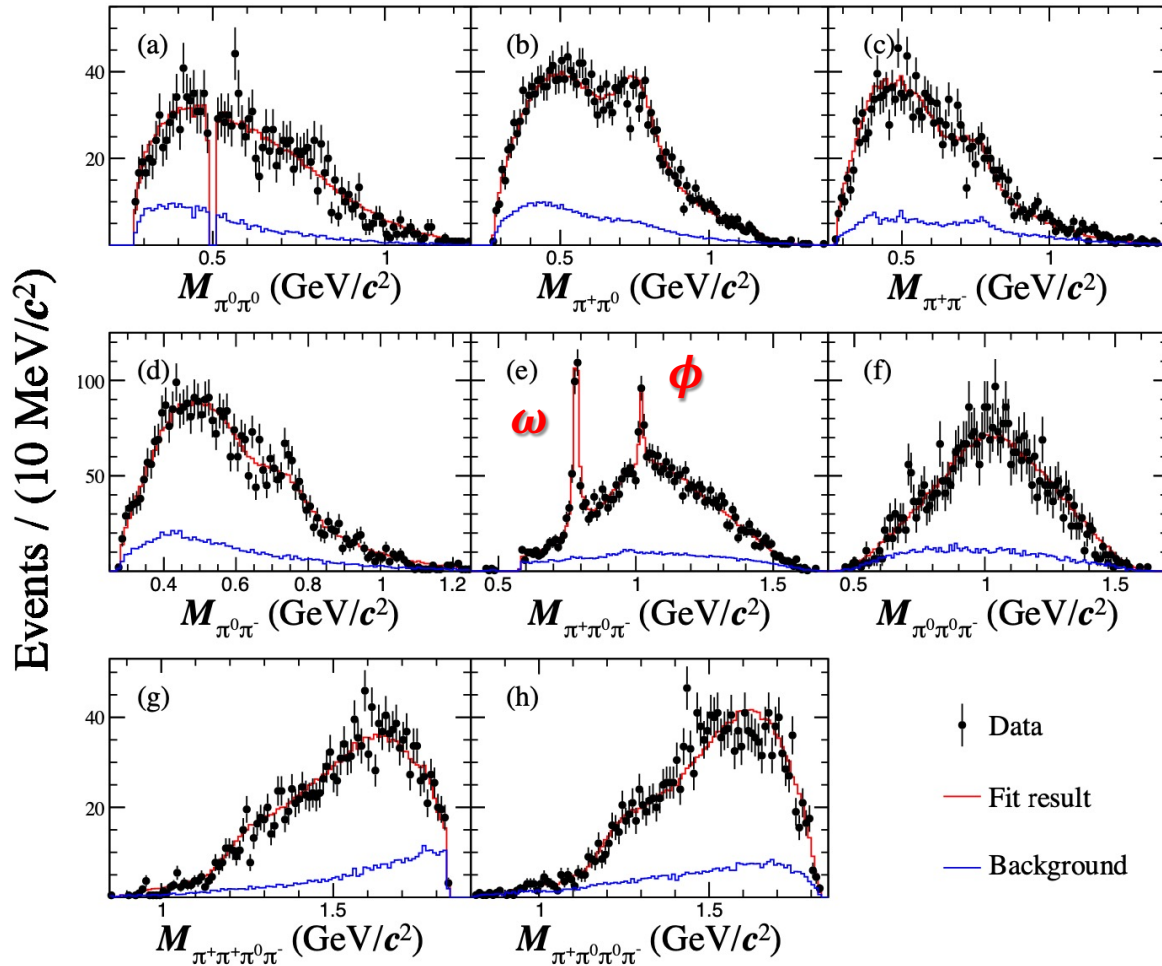

pure W-annihilation $D_s^+ \rightarrow \omega \rho^+$
about 50% D-wave

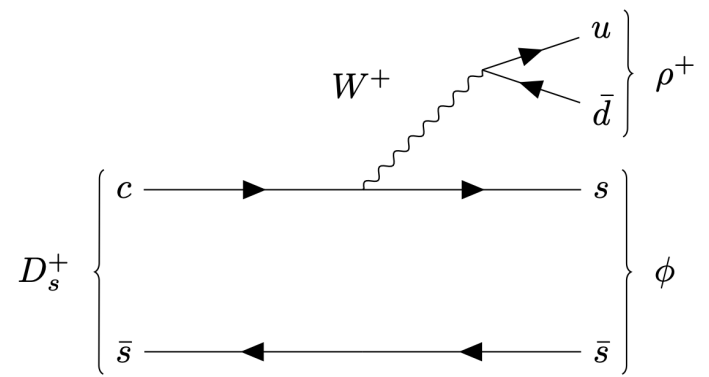

Pure external W emission $D_s^+ \rightarrow \phi \rho^+$
dominated by S-wave

✓ Measurement of ϕ

$$\frac{\mathcal{B}(\phi \rightarrow \pi^+ \pi^- \pi^0)}{\mathcal{B}(\phi \rightarrow K^+ K^-)} = 0.222 \pm 0.019_{\text{stat}} \pm 0.016_{\text{syst}}$$

deviates from PDG $(0.313 \pm 0.010) \%$ by $> 3\sigma$.

Larger than other WA decays

$$\mathcal{B}(D_s^+ \rightarrow \omega \rho^+) = (0.99 \pm 0.08 \pm 0.07)\%$$

$$\mathcal{B}(D_s^+ \rightarrow \phi \rho^+) = (3.98 \pm 0.33 \pm 0.21)\%$$

Amplitude analysis of $D^+ \rightarrow K^- \pi^+ \pi^+ \pi^0$

7.93fb⁻¹@ $E_{cm}=3.773$ GeV
26709 candidates with >98% purity

JHEP 05(2025)195

$D \rightarrow VV$ ✓ Measurement of $D^+ \rightarrow \bar{K}^{*0} \rho^+$
(dominated by S-wave)

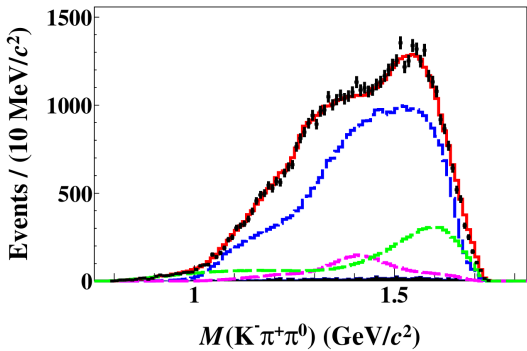
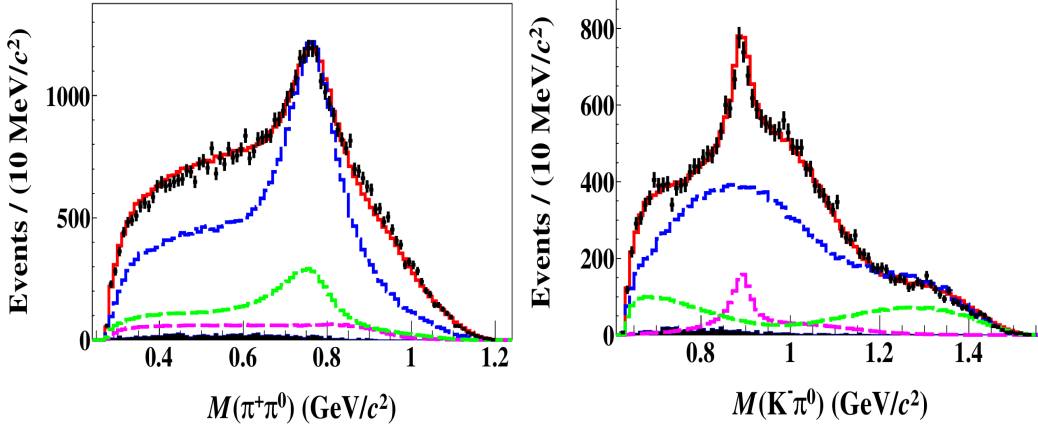
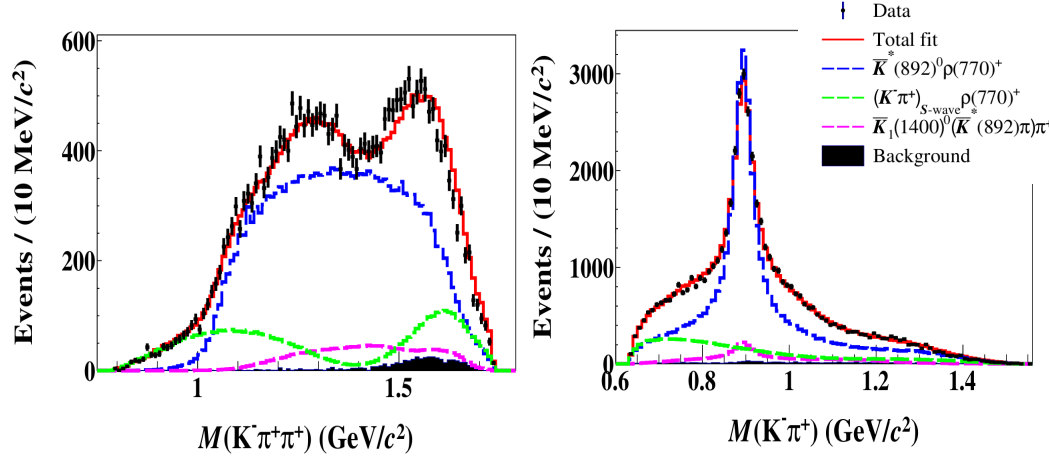

Intermediate process	BF (10 ⁻²)
$D^+ \rightarrow \bar{K}^*(892)^0 \rho(770)^+, \bar{K}^*(892)^0 \rightarrow K^- \pi^+, \rho(770)^+ \rightarrow \pi^+ \pi^0$	$4.35 \pm 0.07 \pm 0.17$
$D^+ \rightarrow \bar{K}_1(1270)^0 \pi^+, \bar{K}_1(1270)^0 \rightarrow K^- \rho(770)^+, \rho(770)^+ \rightarrow \pi^+ \pi^0$	$0.24 \pm 0.02 \pm 0.02$
$D^+ \rightarrow \bar{K}_1(1400)^0 \pi^+, \bar{K}_1(1400)^0 \rightarrow \bar{K}^*(892) \pi, \bar{K}^*(892) \rightarrow K \pi$	$0.46 \pm 0.01 \pm 0.02$
$D^+ \rightarrow \bar{K}^-(1460)^0 \pi^+, \bar{K}^-(1460)^0 \rightarrow \bar{K}^*(892) \pi, \bar{K}^*(892) \rightarrow K \pi$	$0.32 \pm 0.01 \pm 0.02$
$D^+ \rightarrow \bar{K}^-(1680)^0 \pi^+, \bar{K}^-(1680)^0 \rightarrow \bar{K}^*(892) \pi, \bar{K}^*(892) \rightarrow K \pi$	$0.25 \pm 0.02 \pm 0.05$
$D^+ \rightarrow (K^- \pi^+)_{S\text{-wave}} \rho(770)^+, \rho(770)^+ \rightarrow \pi^+ \pi^0$	$1.16 \pm 0.04 \pm 0.05$
$D^+ \rightarrow \bar{K}^-(1460)^0 \pi^+, \bar{K}^-(1460)^0 \rightarrow K^- (\pi^+ \pi^0)_V$	$0.53 \pm 0.05 \pm 0.03$
$D^+ \rightarrow \bar{K}^-(1460)^0 \pi^+, \bar{K}^-(1460)^0 \rightarrow (K^- \pi^0)_V \pi$	$0.22 \pm 0.03 \pm 0.02$
$D^+ \rightarrow (K^- \rho(770)^+)_{A} \pi^+, \rho(770)^+ \rightarrow \pi^+ \pi^0$	$0.11 \pm 0.01 \pm 0.01$
$D^+ \rightarrow (\bar{K}^*(892) \pi)_{A} \pi^+, \bar{K}^*(892) \rightarrow K \pi$	$0.05 \pm 0.01 \pm 0.01$
$D^+ \rightarrow (\bar{K}^*(892) \pi^+)_{A} \pi^0, \bar{K}^*(892)^0 \rightarrow K^- \pi^+$	$0.05 \pm 0.01 \pm 0.02$
$D^+ \rightarrow (K^- \pi^+)_{V} \rho(770)^+, \rho(770)^+ \rightarrow \pi^+ \pi^0$	$0.03 \pm 0.01 \pm 0.01$
$D^+ \rightarrow (K^- (\pi^+ \pi^0)_V)_P \pi^+$	$0.05 \pm 0.01 \pm 0.01$

Decay channel and Collaboration	$\mathcal{B}(D^+ \rightarrow \bar{K}^*(892)^0 \rho(770)^+) (\times 10^{-2})$
$D^+ \rightarrow K^- \pi^+ \pi^+ \pi^0$, current analysis	$6.52 \pm 0.11 \pm 0.26$
$D^+ \rightarrow K^- \pi^+ \pi^+ \pi^0$, MARK-III [4]	$7.2 \pm 1.8 \pm 2.1$
$D^+ \rightarrow K_S^0 \pi^+ \pi^0 \pi^0$, BESIII [21]	$5.82 \pm 0.49 \pm 0.29$

• $\mathcal{B}(D^+ \rightarrow K^- \pi^+ \pi^+ \pi^0) = (6.06 \pm 0.04 \pm 0.07)\%$

Amplitude analysis of $D^0 \rightarrow K^- K^+ \pi^0 \pi^0$

arXiv 2603.25649

$D \rightarrow VV$

✓ Measurement of $D^0 \rightarrow K^{*-} K^{*+}$
(dominated by S-wave)

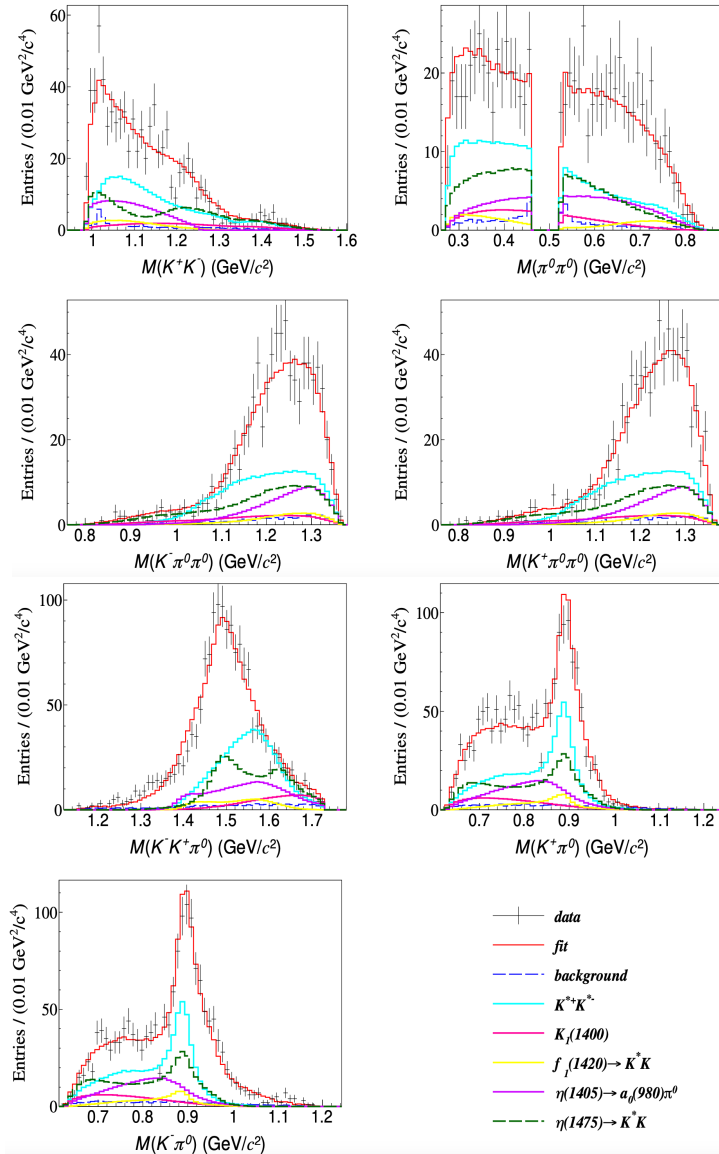

Amplitude	Magnitude	Phase ϕ_n (rad)	FF (%)	Significance (σ)
$D^0[S] \rightarrow K^*(892)^+ K^*(892)^-$	1 (fixed)	0.0 (fixed)	$26.8 \pm 3.5 \pm 1.7$	>10
$D^0[P] \rightarrow K^*(892)^+ K^*(892)^-$	0.70 ± 0.08	$3.00 \pm 0.16 \pm 0.11$	$8.0 \pm 1.8 \pm 0.9$	7.3
$D^0[D] \rightarrow K^*(892)^+ K^*(892)^-$	2.01 ± 0.39	$5.33 \pm 0.20 \pm 0.13$	$4.4 \pm 1.5 \pm 0.5$	3.5
$D^0 \rightarrow K^*(892)^+ K^*(892)^-$	-	-	$40.2 \pm 4.2 \pm 1.5$	-
$D^0 \rightarrow K_1(1400)^+ (\rightarrow K^*(892)^+ \pi^0) K^-$	2.03 ± 0.29	$1.17 \pm 0.18 \pm 0.12$	$8.3 \pm 2.0 \pm 1.5$	6.8
$D^0 \rightarrow f_1(1420) (\rightarrow K^*(892)^+ K^-) \pi^0$	0.85 ± 0.14	$1.38 \pm 0.17 \pm 0.24$	$3.1 \pm 0.8 \pm 0.5$	-
$D^0 \rightarrow f_1(1420) (\rightarrow K^*(892)^- K^+) \pi^0$	0.85 ± 0.14	$1.38 \pm 0.17 \pm 0.24$	$3.1 \pm 0.8 \pm 0.5$	-
$D^0 \rightarrow f_1(1420) \pi^0$	-	-	$8.1 \pm 2.1 \pm 1.1$	7.7
$D^0 \rightarrow \eta(1405) (\rightarrow a_0(980) \pi^0) \pi^0$	1.66 ± 0.18	$2.25 \pm 0.26 \pm 0.30$	$19.0 \pm 2.9 \pm 1.9$	7.8
$D^0 \rightarrow \eta(1475) (\rightarrow K^*(892)^- K^+) \pi^0$	2.06 ± 0.20	$1.20 \pm 0.15 \pm 0.20$	$14.8 \pm 1.7 \pm 1.2$	-
$D^0 \rightarrow \eta(1475) (\rightarrow K^*(892)^+ K^-) \pi^0$	2.06 ± 0.20	$1.20 \pm 0.15 \pm 0.20$	$14.8 \pm 1.7 \pm 1.2$	-
$D^0 \rightarrow \eta(1475) \pi^0$	-	-	$33.7 \pm 3.9 \pm 2.4$	>10
Total			102.3	

$$\mathcal{B}(D^0 \rightarrow K^+ K^- \pi^0 \pi^0) = (0.73 \pm 0.03 \pm 0.01) \times 10^{-3}$$

$D_s^+ \rightarrow K^+ K^+ \pi^- (\pi^0)$

Phys. Rev. D 109, 032011 (2024)

Data: 7.33 fb^{-1} 4.128 - 4.226 GeV

--Doubly Cabibbo-suppressed (DCS) decays

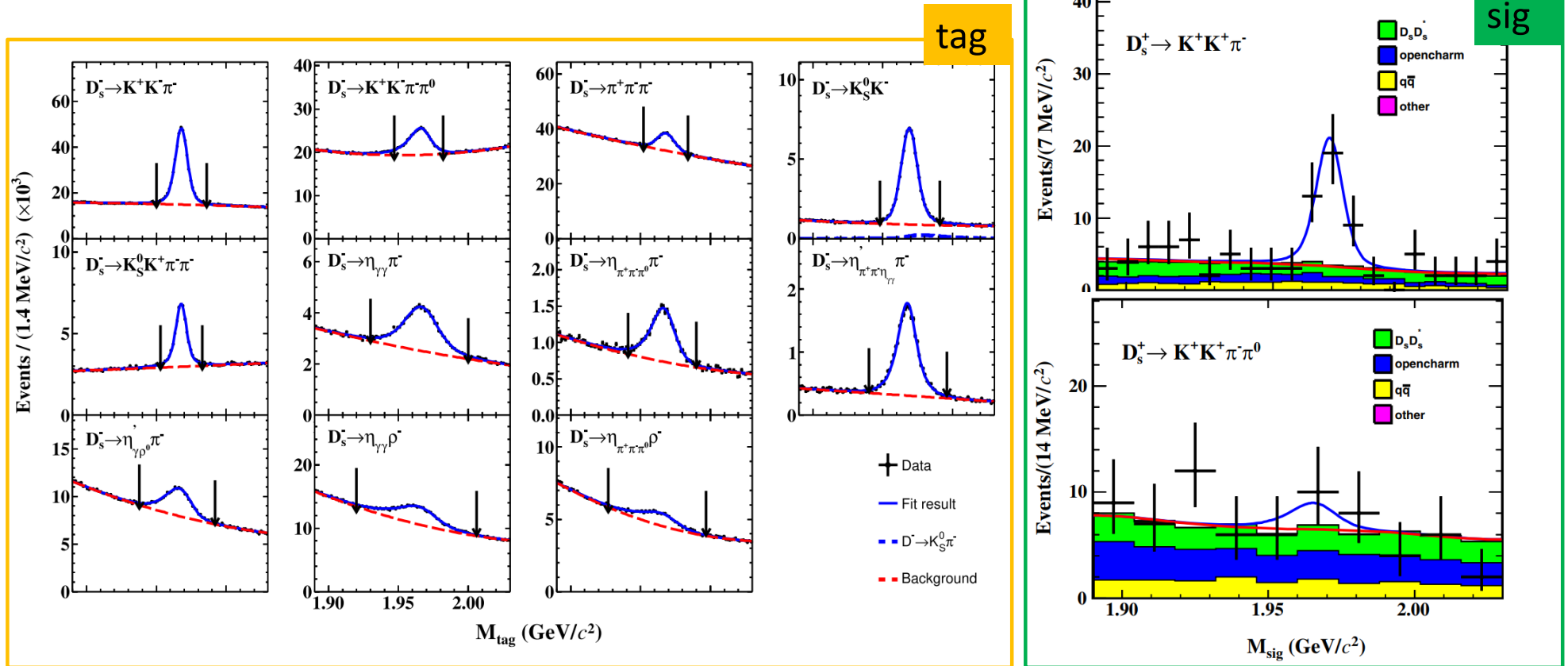

DCS decay	$\mathcal{B}_{\text{DCS}}^{\text{this work}} (\times 10^{-4})$	CF decay	$\mathcal{B}_{\text{CF}}^{\text{PDG}} (\times 10^{-2})$	$\mathcal{B}_{\text{DCS}}^{\text{this work}} / \mathcal{B}_{\text{CF}}^{\text{PDG}} (\times 10^{-3})$	$\times \tan^4 \theta_C$
$D_s^+ \rightarrow K^+ K^+ \pi^-$	$1.24^{+0.28}_{-0.26} \pm 0.06$	$D_s^+ \rightarrow K^+ K^- \pi^+$	5.37 ± 0.10	$2.31^{+0.52}_{-0.48}$	$0.80^{+0.18}_{-0.16}$
$D_s^+ \rightarrow K^+ K^+ \pi^- \pi^0$	< 1.7	$D_s^+ \rightarrow K^+ K^- \pi^+ \pi^0$	5.50 ± 0.24	< 3.09	< 1.07

$D_s^+ \rightarrow K^+ K^+ \pi^-$: $33.3^{+7.6}_{-6.9}$ signal events, $D_s^+ \rightarrow K^+ K^+ \pi^- \pi^0$: No significant signal.

$D^+ \rightarrow K^+ \pi^0, K^+ \eta, K^+ \eta'$

arXiv:2506.15533

Data: 20.3 fb⁻¹ 3.773 GeV

--Doubly Cabibbo-suppressed (DCS) decays

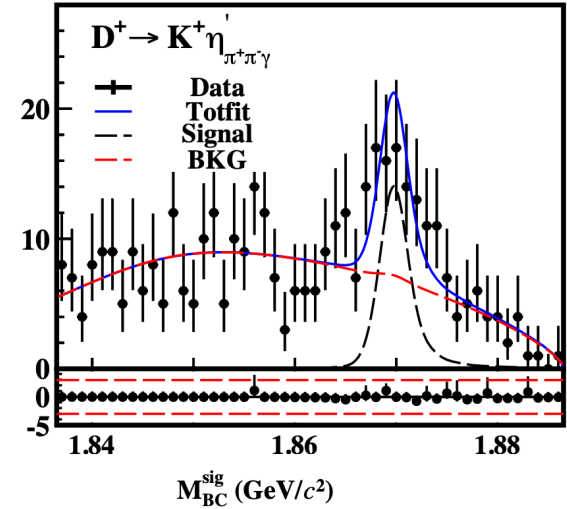
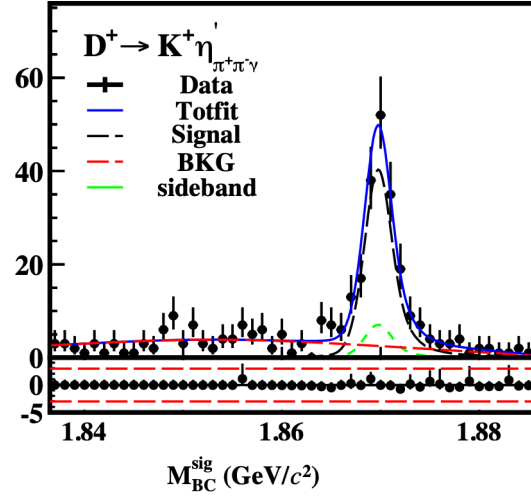
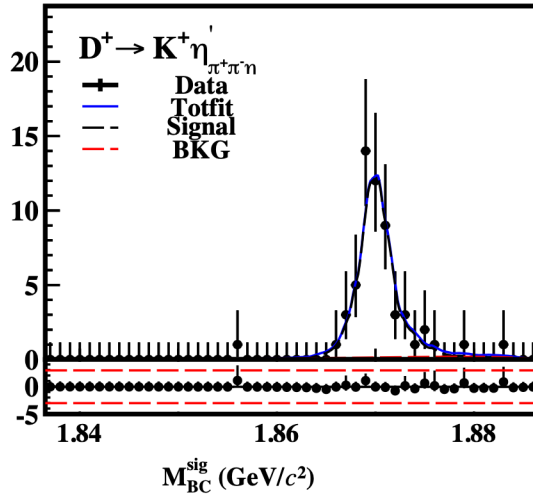

Signal decay	$D^+ \rightarrow K^+ \pi^0$	$D^+ \rightarrow K^+ \eta$	$D^+ \rightarrow K^+ \eta'$
CLEO [12]	$2.28 \pm 0.36 \pm 0.17$
Belle [13]	...	$1.15 \pm 0.16 \pm 0.05$	$1.87 \pm 0.19 \pm 0.05$
BaBar [14]	$2.52 \pm 0.47 \pm 0.26$
BESIII [15]	$2.32 \pm 0.21 \pm 0.06$	$1.51 \pm 0.25 \pm 0.14$	$1.64 \pm 0.51 \pm 0.24$
PDG [16]	2.08 ± 0.21	1.25 ± 0.16	1.85 ± 0.20
DASU(3)L [1]	1.59 ± 0.15	0.98 ± 0.04	0.91 ± 0.17
TASU(3)B [2]	2.54 ± 0.06	1.04 ± 0.01	1.07 ± 0.01
GFRE [3]	2.2 ± 0.4	1.2 ± 0.2	1.0 ± 0.1
FDWC [4]	1.97	0.66	1.14
This work	$1.45 \pm 0.06 \pm 0.06$	$1.17 \pm 0.10 \pm 0.03$	$1.88 \pm 0.15 \pm 0.06$

Quantum Correlation

Quantum correlated data: $e^+ e^- \rightarrow \psi(3770) \rightarrow D^0 \bar{D}^0$

Best laboratory to measure strong-phase parameters

CP-odd: $\psi(3770) = (D^0 \bar{D}^0 - D^+ D^-) = (D_+ D_- - D_- D_+)$

$J^{PC} = 1^{--}$

CP-even eigenstate

CP-odd eigenstate

• Inputs for CPV studies at B experiments

• The CKM angle γ/ϕ_3 :

self-conjugated decay: CP fraction F_+ \rightarrow GLW/GGSZ method;

strong phase $ci(')$ and $si(')$ \rightarrow GGSZ method

non-self-conjugated decay: the coherence factor R and averaged

strong phase difference $\delta \rightarrow$ ADS method

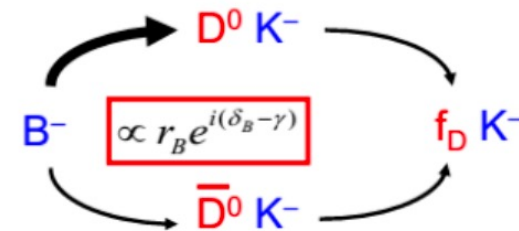

Determination of $\delta_D^{K\pi}$

- An update measurement of the asymmetry between CP-odd and CP-even eigenstate decays into $K^- \pi^+$

$$A_{K\pi} \equiv \frac{\mathcal{B}(D_- \rightarrow K^- \pi^+) - \mathcal{B}(D_+ \rightarrow K^- \pi^+)}{\mathcal{B}(D_- \rightarrow K^- \pi^+) + \mathcal{B}(D_+ \rightarrow K^- \pi^+)} = \frac{-2r_D^{K\pi} \cos \delta_D^{K\pi} + y}{1 + (r_D^{K\pi})^2} = 0.132 \pm 0.011 \pm 0.007$$

30% more precise !

- $\delta_D^{K\pi} = (187.6_{-9.7}^{+8.9+5.4})$

EPJC 82, 1009 (2022)

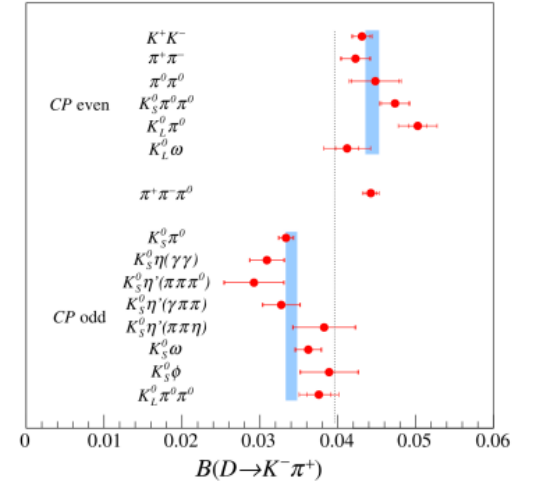

Determination of CP fraction

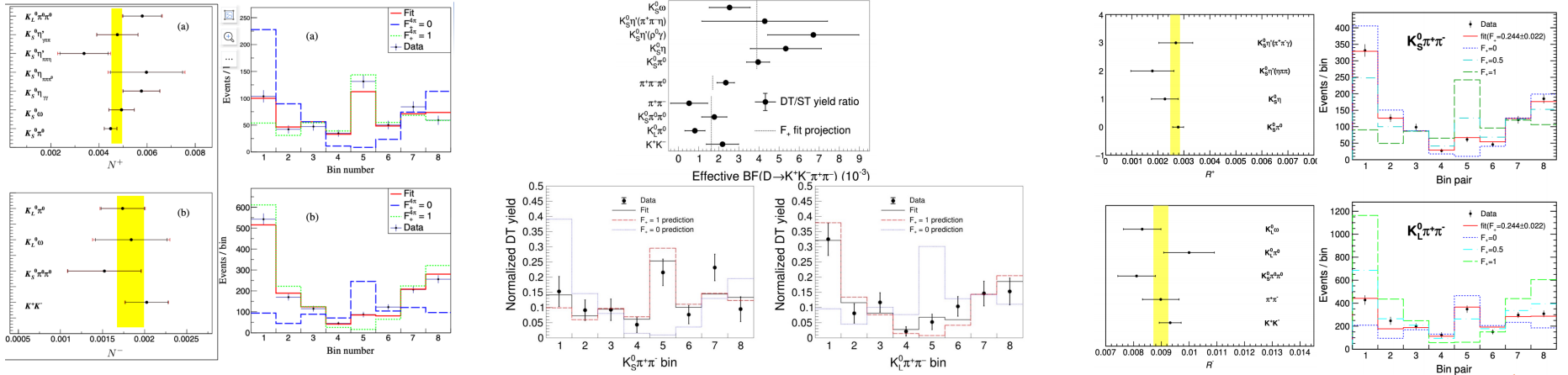

$$D^0 \rightarrow \pi^+ \pi^- \pi^+ \pi^-$$

$$F_+ = 0.735 \pm 0.015 \pm 0.005$$

PRD 106, 092004(2022)

$$D^0 \rightarrow K^+ K^- \pi^+ \pi^-$$

$$F_+ = 0.730 \pm 0.037 \pm 0.021$$

PRD 107, 032009(2023)

$$D^0 \rightarrow K_S^0 \pi^- \pi^+ \pi^0$$

$$F_+ = 0.235 \pm 0.010 \pm 0.002$$

PRD 108, 032003 (2023)

Quantum Correlated $D^0\bar{D}^0$ pairs

7.13 fb⁻¹ @4.13 – 4.23 GeV
arXiv:2506.07906



Studies of quantum correlations in

$$e^+e^- \rightarrow \gamma^* \rightarrow XD\bar{D}$$

→ Quantum correlated C-odd $D^0\bar{D}^0$ pairs used at $\psi(3770)$ for D -decay strong phase measurements

$$\begin{cases} C_\gamma = -1 \\ C_{\pi^0} = +1 \end{cases}$$

First observation of quantum correlations in $e^+e^- \rightarrow XD\bar{D}$ and C-even constrained $D\bar{D}$ pairs

Production mechanism	C
$e^+e^- \rightarrow D\bar{D}$	-1
$e^+e^- \rightarrow D^*\bar{D} \rightarrow D\bar{D} \gamma$	+1
$e^+e^- \rightarrow D^*\bar{D} \rightarrow D\bar{D} \pi^0$	-1
$e^+e^- \rightarrow D^*\bar{D}^* \rightarrow D\bar{D} \gamma\gamma$	-1
$e^+e^- \rightarrow D^*\bar{D}^* \rightarrow D\bar{D} \pi^0\gamma$	+1
$e^+e^- \rightarrow D^*\bar{D}^* \rightarrow D\bar{D} \pi^0\pi^0$	-1

$$\hat{C} |D\bar{D}\rangle = \kappa C_{\text{exp}} |D\bar{D}\rangle - (1 - \kappa) C_{\text{exp}} |D\bar{D}\rangle$$

Contribute more statistics for quantum-correlation studies!!

Production mechanism	κ
$D\bar{D}$	1.015 ± 0.066
$D^*\bar{D} \rightarrow \gamma D\bar{D}$	1.044 ± 0.044
$D^*\bar{D} \rightarrow \pi^0 D\bar{D}$	1.028 ± 0.024
$D^*\bar{D}^* \rightarrow \gamma\pi^0 D\bar{D}$	1.027 ± 0.017
$D^*\bar{D}^* \rightarrow \gamma\gamma/\pi^0\pi^0 D\bar{D}$	0.963 ± 0.060

$\kappa=1$: coherent
 $\kappa=0.5$: incoherent

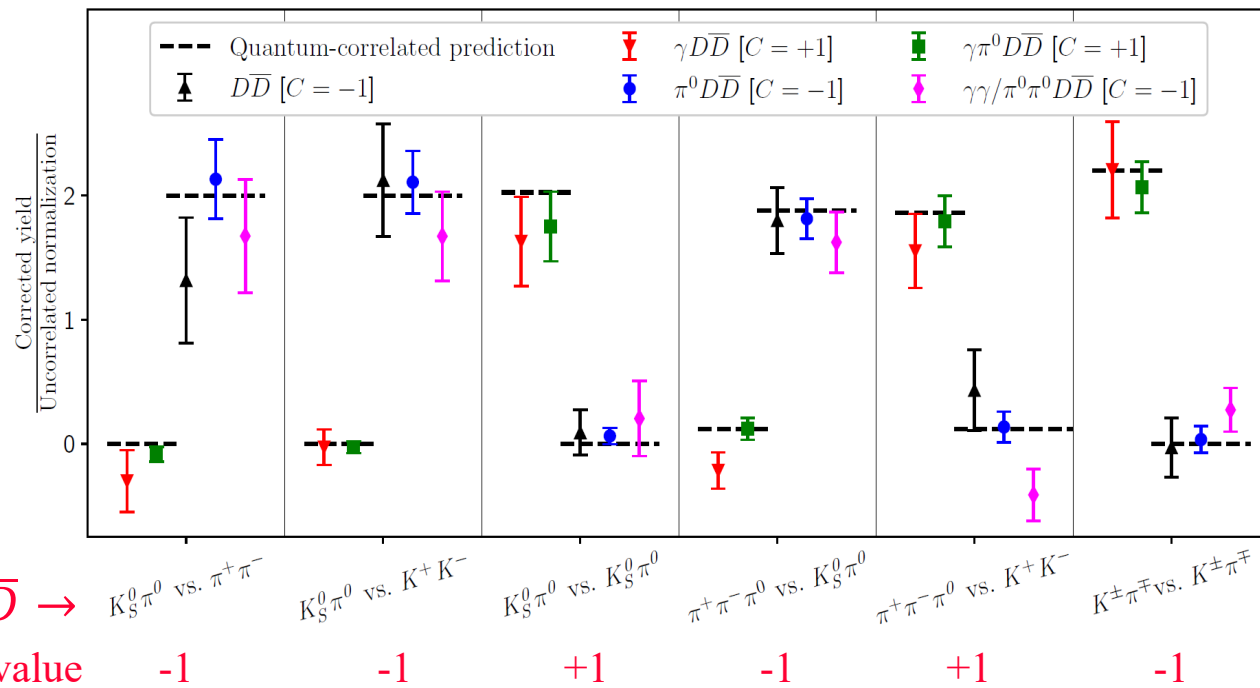

☞ $\delta_{K\pi}$ is the strong-phase difference between $D^0 \rightarrow K^- \pi^+$ and $D^0 \rightarrow K^+ \pi^-$ decays

$$r_{K\pi}^D e^{-i\delta_{K\pi}^D} = \frac{A(\bar{D}^0 \rightarrow K^- \pi^+)}{A(D^0 \rightarrow K^- \pi^+)}, \quad r_{K\pi}^D \text{ is the magnitude of the ratio}$$

key input for measurements of the charm mixing parameters and CKM angle γ

☞ Use the quantum correlated pairs to measure $\delta_{K\pi}$

→ CP tags ($K^+ K^-$, $\pi^+ \pi^-$, $\pi^+ \pi^- \pi^0$, $K_S^0 \pi^0$)
($r_{K\pi} \cos \delta_{K\pi}$)

→ $K_S^0 \pi^+ \pi^-$ tags ($r_{K\pi} \cos \delta_{K\pi}$ and $r_{K\pi} \sin \delta_{K\pi}$)

Source	Observable	Value
$D \rightarrow CP$	$r_{K\pi}^D \cos \delta_{K\pi}^D$	$-0.070 \pm 0.008 \pm 0.0015$
$D \rightarrow K_S^0 \pi^+ \pi^-$	$r_{K\pi}^D \cos \delta_{K\pi}^D$	$-0.044 \pm 0.014 \pm 0.0018$
$D \rightarrow K_S^0 \pi^+ \pi^-$	$r_{K\pi}^D \sin \delta_{K\pi}^D$	$-0.022 \pm 0.017 \pm 0.0031$

☞ Extract $\delta_{K\pi}$

$$\delta_{K\pi}^D = (192.8_{-12.4-2.4}^{+11.0+1.9})^\circ \quad \text{agree with global average} \quad \delta_{K\pi}^D = (190.2 \pm 2.8)^\circ$$

[LHCb, CERN-LHCb-CONF-2024-004]

☞ BESIII combination (with BESIII 2.93 fb⁻¹ $\psi(3770)$ result)

$$\delta_{K\pi}^D = (187.6_{-9.7-6.4}^{+8.9+5.4})^\circ$$

[BESIII, EPJC 82,1009(2022)]

$$\delta_{K\pi}^D = (189.2_{-7.4-3.8}^{+6.9+3.4})^\circ$$

Expected precision for γ

Strong phase measurements with data at $E_{\text{cm}} = 3.773 \text{ GeV}$.

Decay	Parameter	σ_{expected} (20.3 fb ⁻¹)	σ_{expected} (200 fb ⁻¹)	$\sigma(\gamma)/\text{LHCb}$
$K_S^0 h^+ h^-$	c_i, s_i	0.5°	0.2°	~5°/Run 1+2
$K\pi$	δ_D	~5°	~1.5°	-
$K\pi\pi\pi$	R, δ_D	~2.5°	~0.7°	~6°/Run 1+2
$K_S^0 K\pi$	$R\cos\delta_D$ $R\sin\delta_D$	~3.0°	~0.9°	<6°/Toy Run 1+2
$h^+ h^- \pi$	c_i, s_i	-	-	-
$\pi\pi\pi\pi$	c_i, s_i	0.88°	~0.3°	~9°/Run 1+2
$KK\pi\pi$	c_i, s_i	12.7°	~4°	-
$K_S^0 \pi\pi\pi$	c_i, s_i	~1.2°	~0.4°	-

1/5~1/6 smaller (~1°) with LHCb Run 3+4 data

Summary & Outlook

- Charm hadronic decays are key labs to understand non-perturbative QCD
- Amplitude analysis is a robust approach that bridges theory and experiment
 - branching fractions for key $D \rightarrow VP$ decays, including $D \rightarrow K^*\pi$ and $D_s \rightarrow \phi\pi$.
 - branching fractions for decays involving scalar or axial-vector
 - the CP-even fraction for D^0 multi-body decays
 - measurement of the phi decay
 - polarization observables in $D \rightarrow VV$
 - $K_S^0 - K_L^0$ asymmetry, U-spin symmetry, and quantum correlations
- More interesting results are coming using $20.3 \text{ fb}^{-1} \psi(3770)$ data.

Thanks for your attention!