

MIXE Spectrometer based on CZT and HPGe

You Lv, CSNS
On behalf of MELODY Team

International Workshop on Muon Physics at the
Intensity and Precision Frontiers (MIP2026)



中国科学院高能物理研究所
Institute of High Energy Physics Chinese Academy of Sciences



中国散裂中子源

China Spallation Neutron Source

Outlines

- **MELODY Beamlines**
- **MIXE Technique and Applications**
- **MIXE Spectrometer for MELODY**
- **Summary**

CSNS-II Project

CSNS-II have been started construction from March 2024.

◆ CSNS-II upgrade

- Superconducting Linac: 300MeV
- RCS: 1.6GeV, 25Hz, 500kW
- Nine more neutron spectrometers
- High energy proton application terminal
- **MELODY** (Muon station for science, technology and industry)

◆ **The MELODY project will extract 1 pulse from the 25Hz proton beam to hit on a stand-alone target to generate muons.**

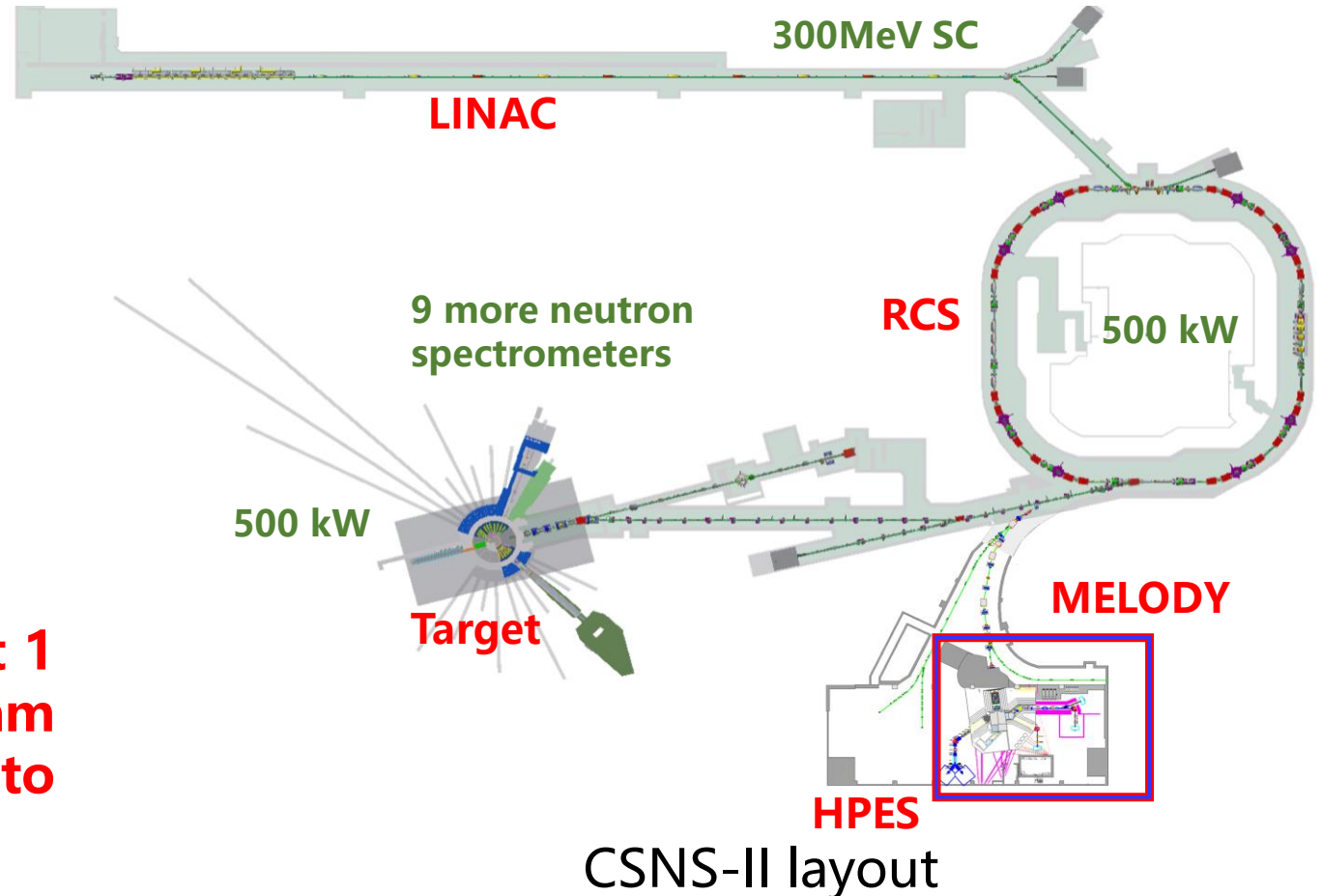

MELODY Project

◆ Proton beam parameters:

- Energy: 1.6 GeV,
- Beam power: 20 kW
- Repetition rate: 1 Hz (double bunches)
- Pulse width: 120 ns

◆ The devices inside the target station will be installed in the last half of this year.



MELODY Beamlines

◆ SMBT (SMT1 & SMT2), NMBT and DMBT are designed

- SMBT: Surface muon, 2 terminals, μ SR, MIXE technique and muon beam study.
- NMBT: Negative muon, 1 terminal, MIXE technique.
- DMBT: Decay muon, 2 terminals, MIXE and μ SR technique.

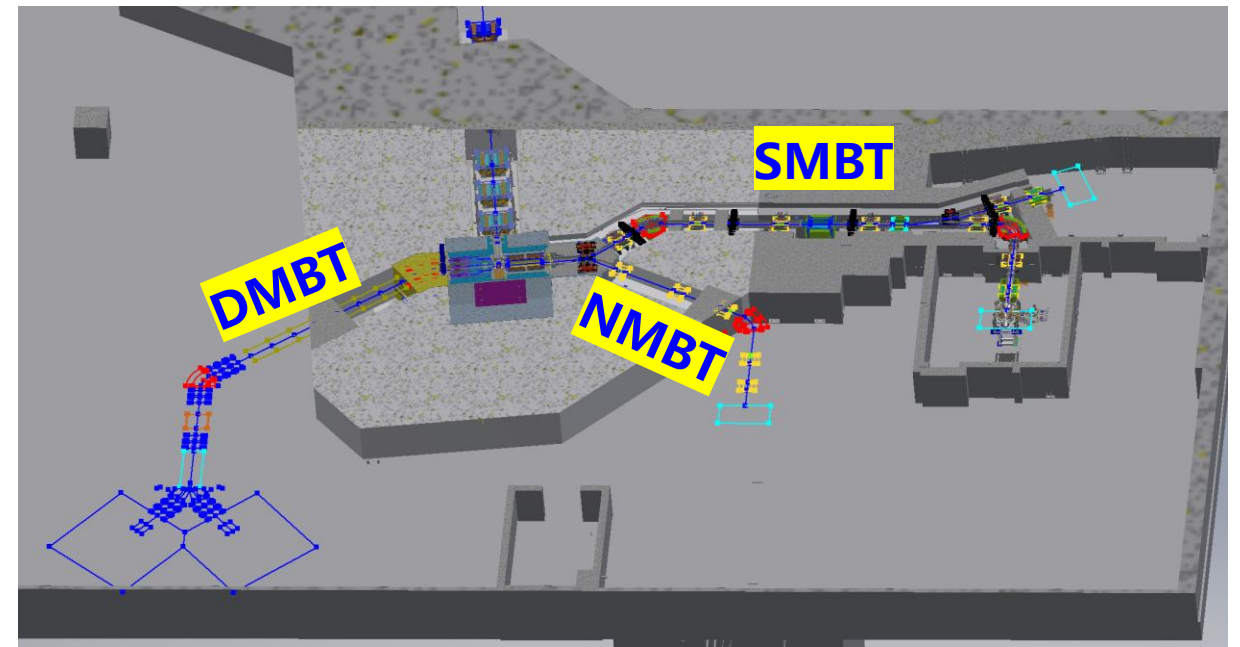
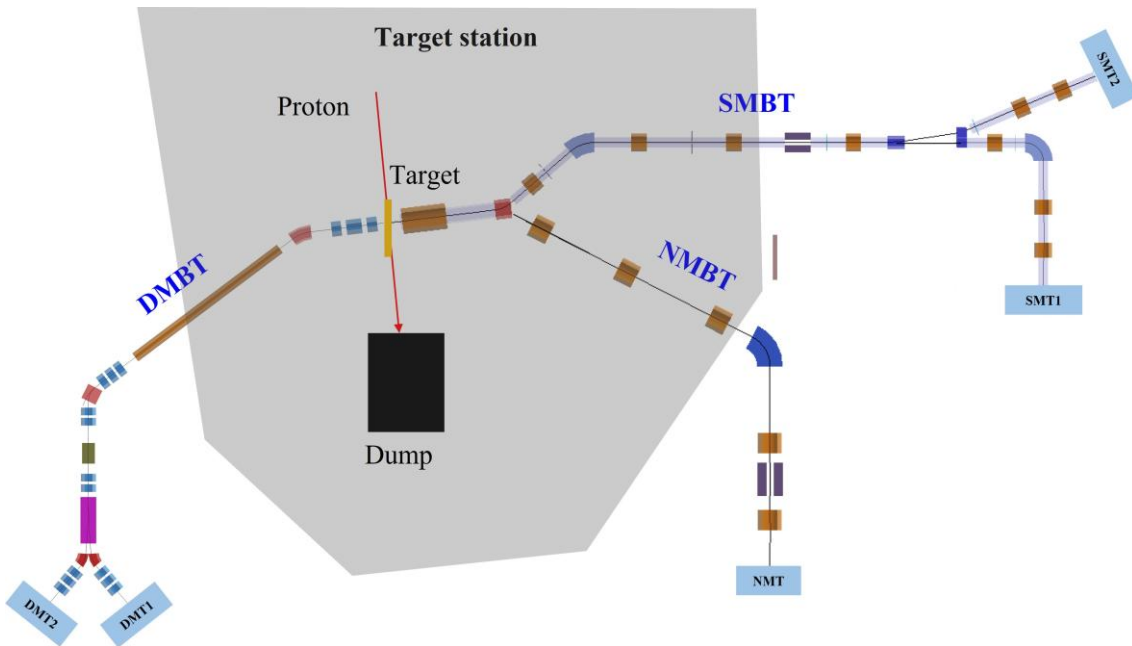

MELODY Beamline layout

Surface muon beamline

◆ SMBT: Transport surface muon (μ SR) or negative muon (MIXE).

- Radiation-Resistant solenoid: capture muon
- Fully solenoids focusing: high acceptance and cost-efficient
- Dipole, Wien Filter, Kicker, Septum, Collimators

1. Momentum: ~ 28 MeV/c, Polarization: $> 95\%$ @ μ^+

2. Intensity: $> 10^7$ μ^+ /s, $> 10^5$ μ^- /s

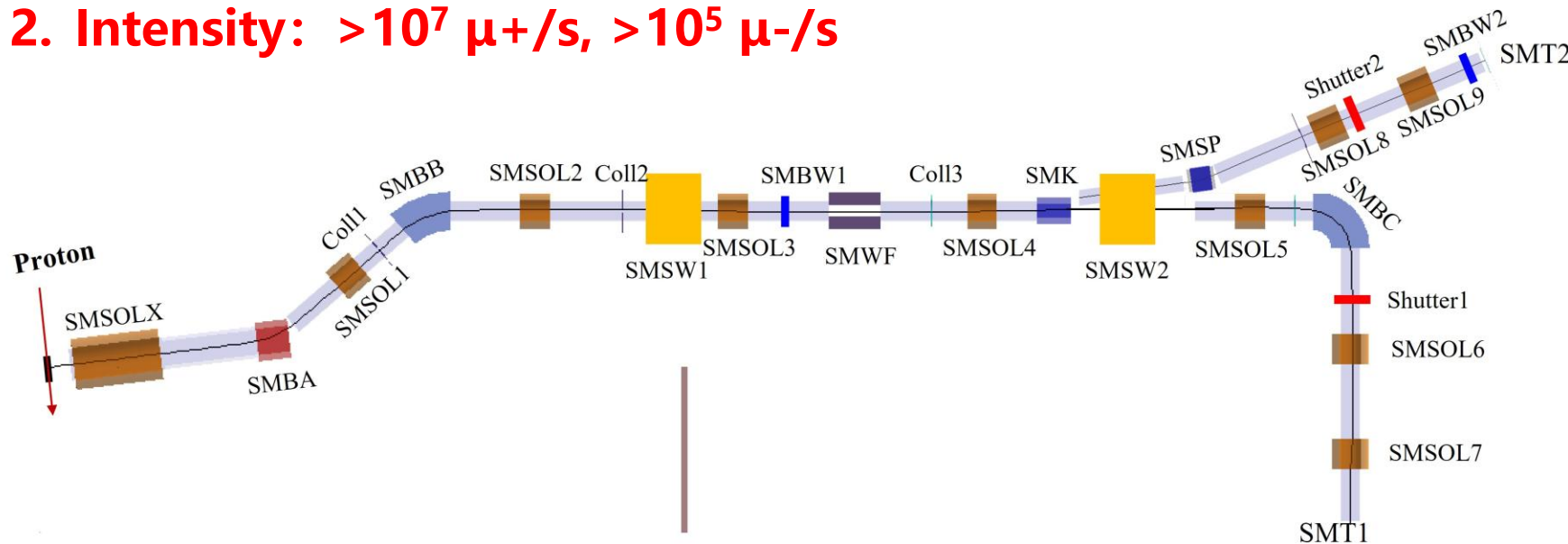

SMBT layout

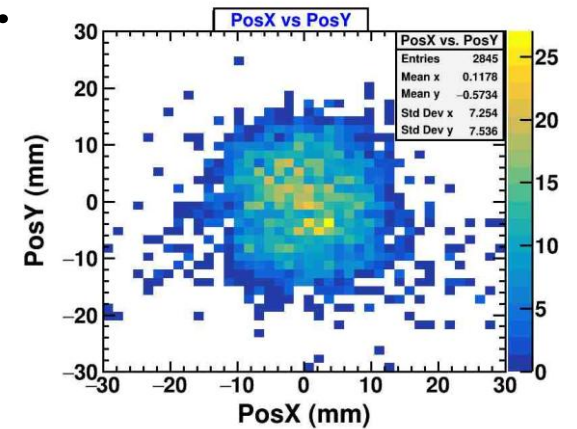

Beam spot @ $\Phi 30$ mm

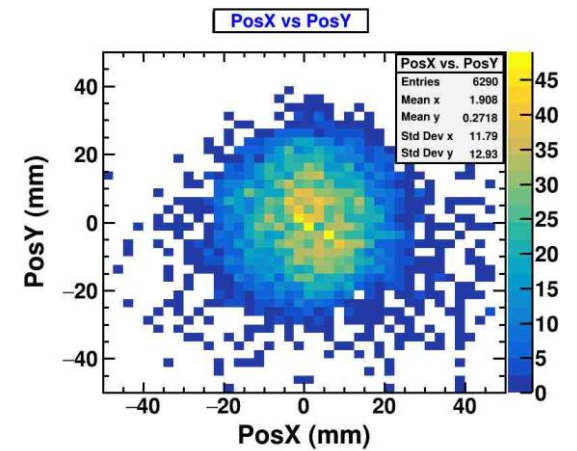

Beam spot @ $\Phi 50$ mm

Negative Muon Beamline

◆ NMBT: dedicated for MIXE application, operation simultaneously with the SMBT.

◆ NMBA, NMBB: Dipole Corrector magnets to transport different momentum of negative muons.

- Fully solenoids focusing: high acceptance and cost-efficient
- Wien Filter, Collimators

1. Momentum: 20 to 60 MeV/c

2. Intensity: 10^4 to 10^6 μ^-/s

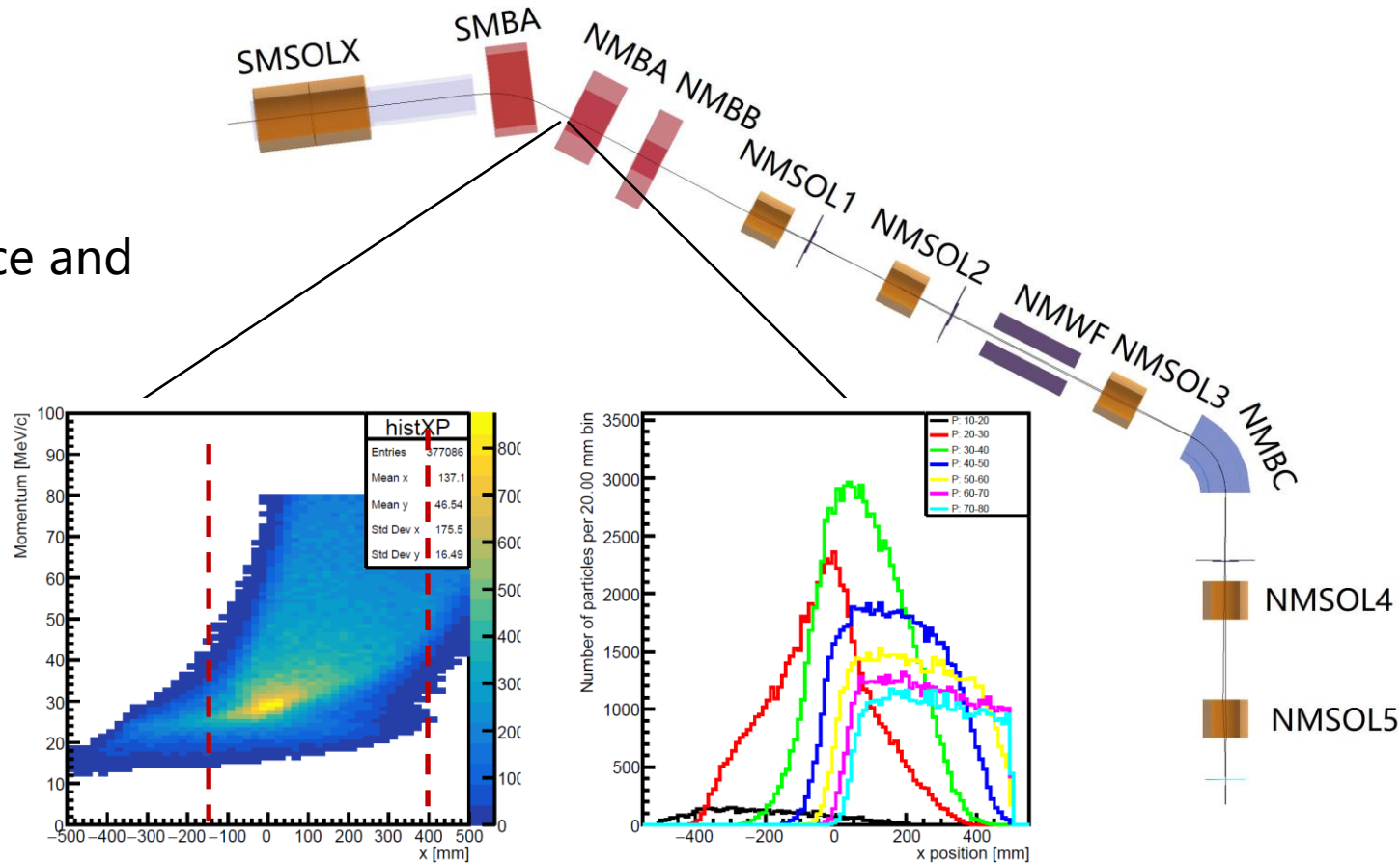

Muon distribution before NMBA

Decay Muon Beamline

◆ DMBT: MIXE and μ SR applications.

- π -collecting section: Quadrupole to collect the pion and muons.
- Decay section: SC magnet to capture muon decay from pion.
- Transport section: Quadrupole to focus muon

1. **Momentum: 20-120 MeV/c**
2. **Intensity: $6 \times 10^5 \mu^- / s$ @ 120 MeV/c**
3. **Momentum dispersion: 5% @120 MeV/c**

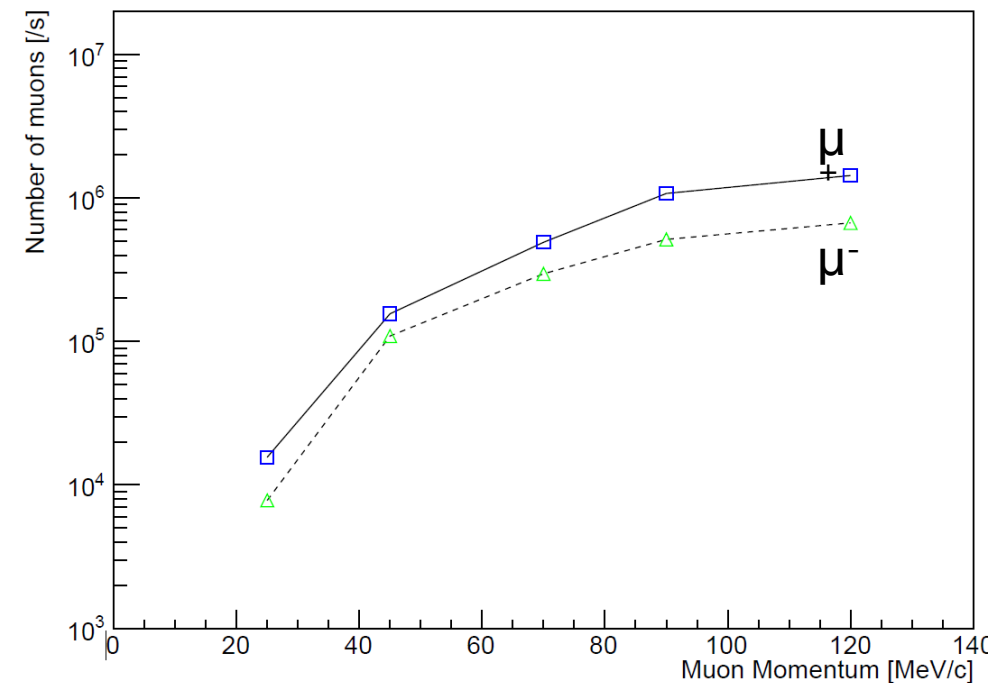
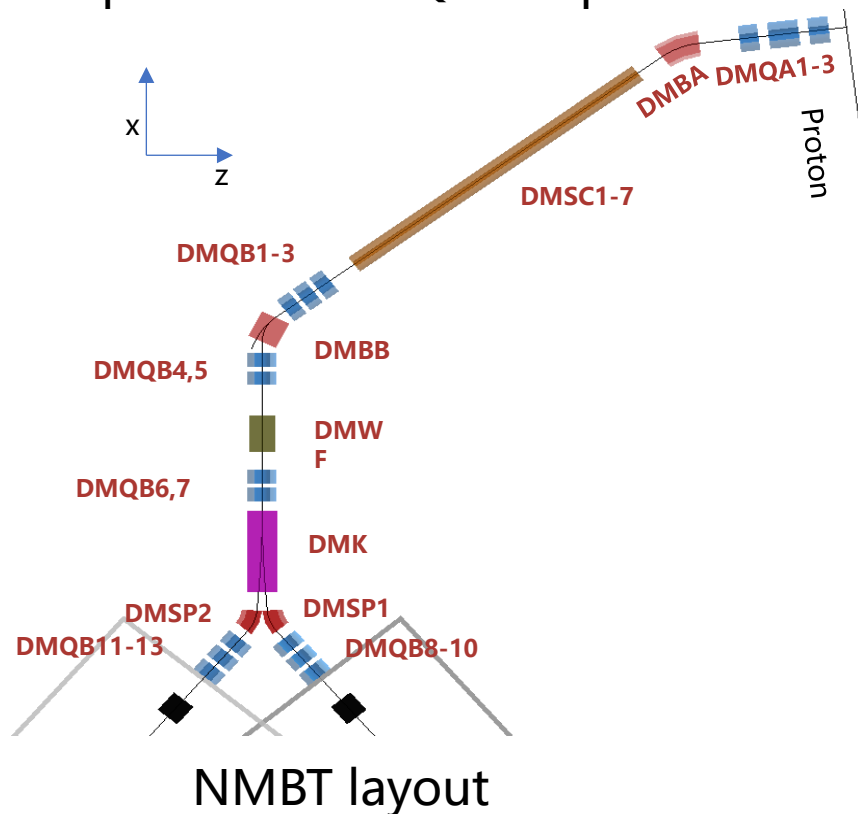

Beam intensity vs. Momentum

MELODY Parameters

Beamline	Terminal	Intensity (μ/s)	Polarization	Momentum (MeV/c)	Momentum dispersion (FWHM)
SMBT	SMT1	1.6×10^7 @ $\mu+$ 1.8×10^5 @ $\mu-$	95% *	28	~7%
	SMT2	1.8×10^7 @ $\mu+$	95%	28	~6%
NMBT	NMT	6×10^5 @ $\mu-$	*	20-60	13%
DMBT	DMT1	3.5×10^6 @ $\Phi 30$	*	20-120	8%
	DMT2	3.5×10^6 @ $\Phi 30$	*	20-120	8%

Timeline of MELODY

MELODY will open operation in 2029.

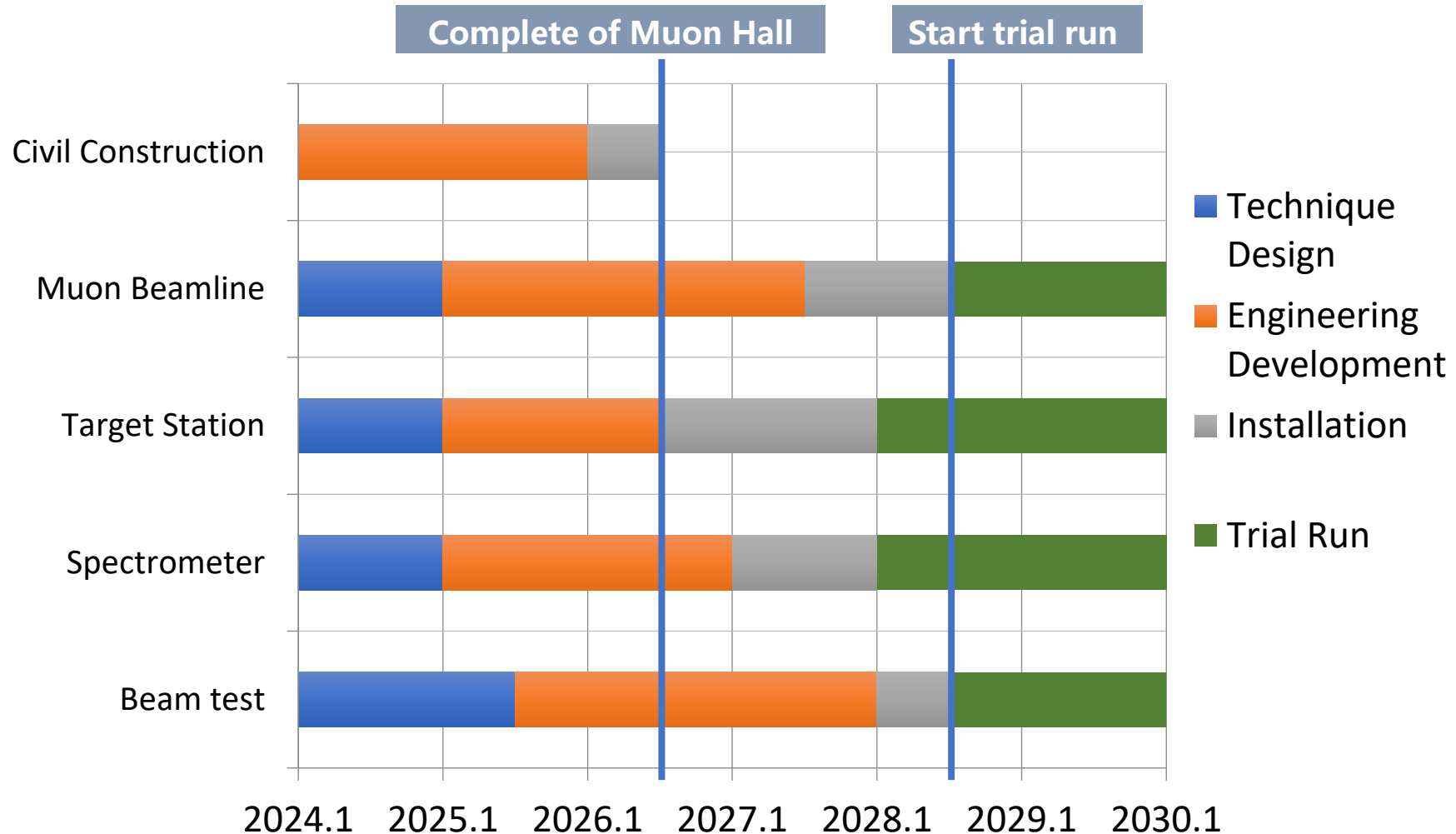

Outlines

- MELODY Beamlines
- **MIXE Technique and Applications**
- MIXE Spectrometer for MELODY
- Summary

MIXE Technique

◆ MIXE: Muon Induced Xray Emission

- μ^- injected into a material and captured by the nucleus, forming muonic atom.
- muonic atom de-excite and emit X-rays.
- Nucleus identifying according the μ -Xray energy.

μ -Xray Energy:

$$E_{i \rightarrow f, \mu} = \frac{m_{\mu}}{m_e} R \left(\frac{1}{n_f^2} - \frac{1}{n_i^2} \right) \approx \frac{m_{\mu}}{m_e} E_{i \rightarrow f, e} \approx 207 \times E_{i \rightarrow f, e}$$

Element	Ka	Kb	La	Lb
C	76	89	14	19
O	134	158	25	34
Al	347	422	66	89
Fe	1256	1704	264	357

μ -Xray energy of typical element

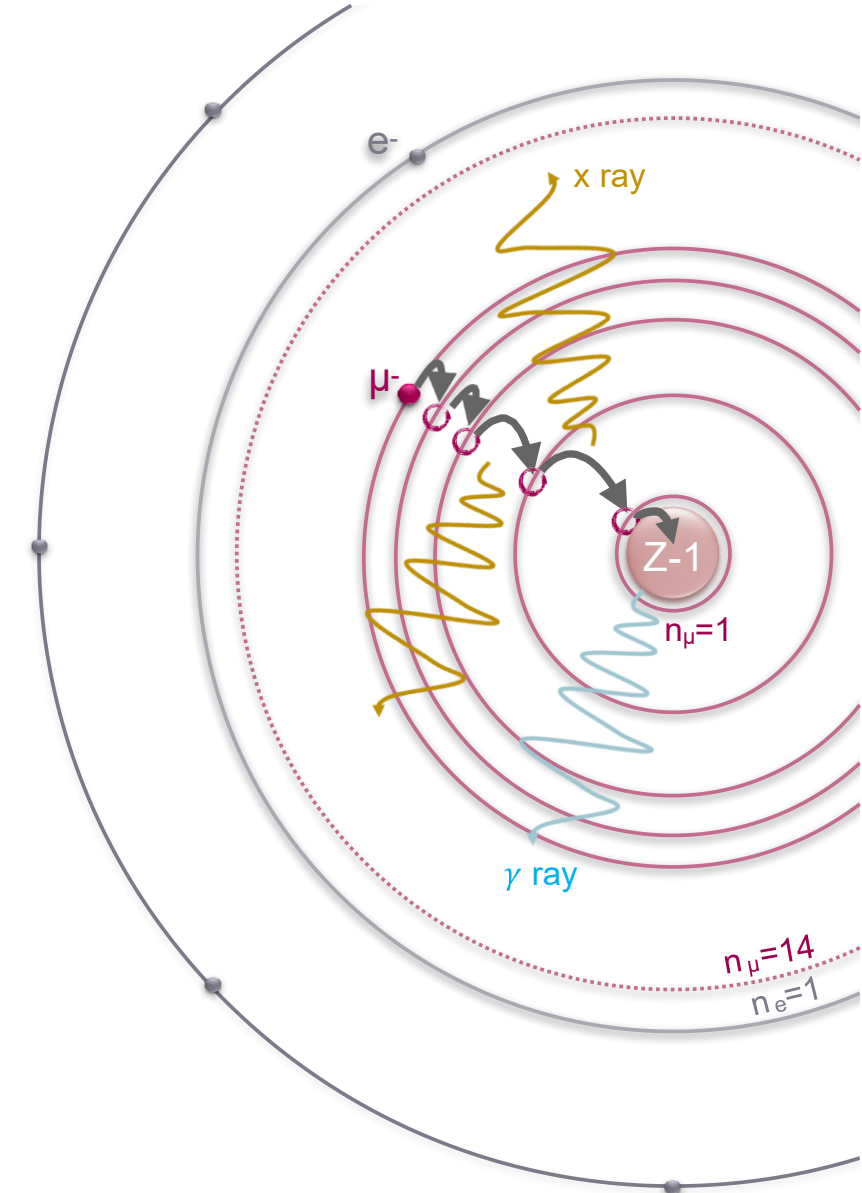

Characteristics of MIXE

◆ MIXE Features

- Non-destructive elemental analysis
- Depth scanning
- High sensitivity to low Z materials
- 3D elemental tomography

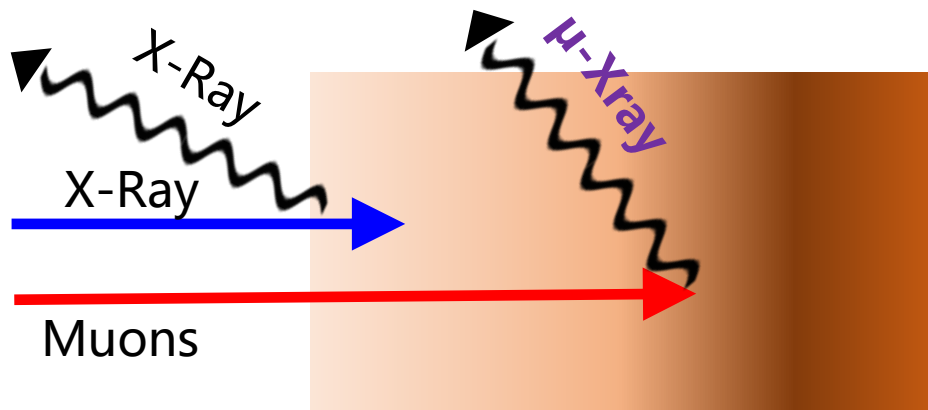

- **XRF: Depth @ μm ~100 μm , $Z > 11$**
- **MIXE: Depth @ μm ~10cm, almost all elements**

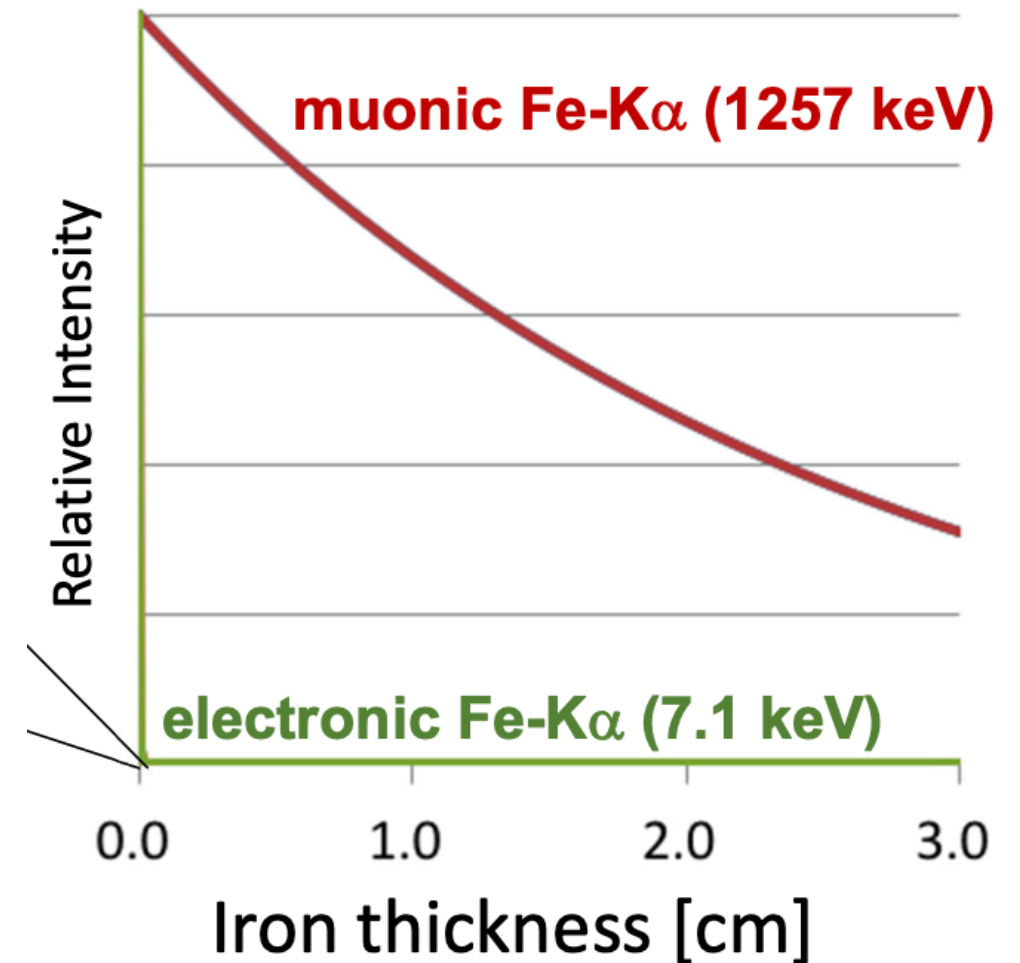

MIXE Spectrometer

◆ HpGe detector array: the commonly used detector

- High efficiency and excellent energy resolution
- Need cooling to reduce noise, expensive

◆ Double-sided strip CdTe: imaging detector system

- High detection granularity
- Better energy resolution: $\sim 2.7\%$ @60keV

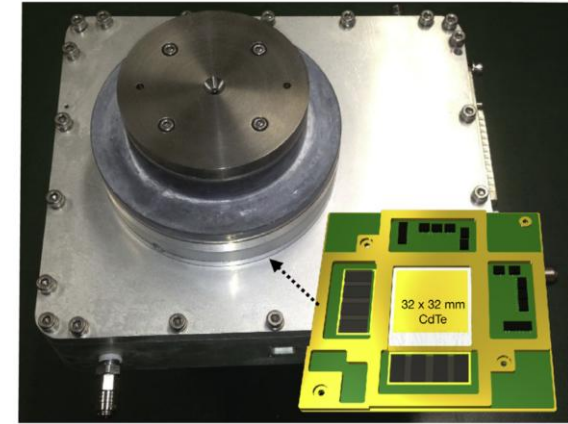

CdTe @ double-sided strip

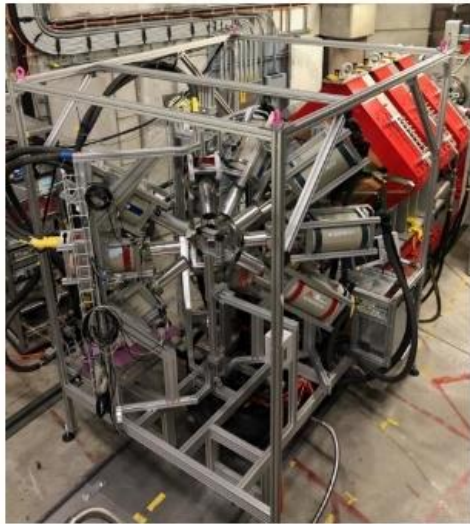

PSI HpGe array

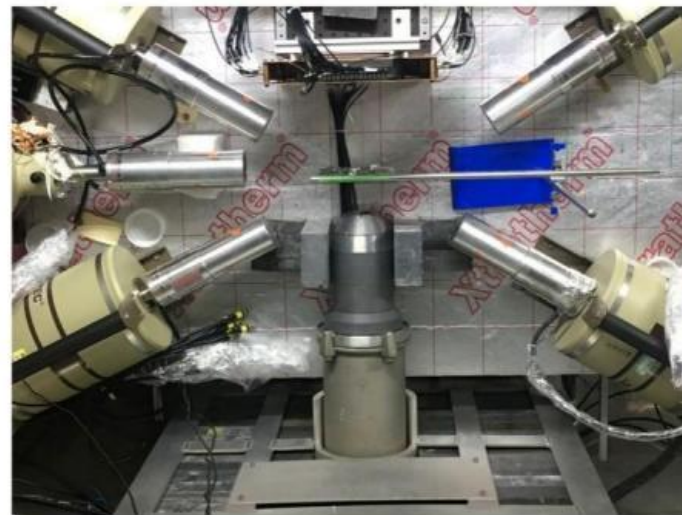

ISIS HpGe array

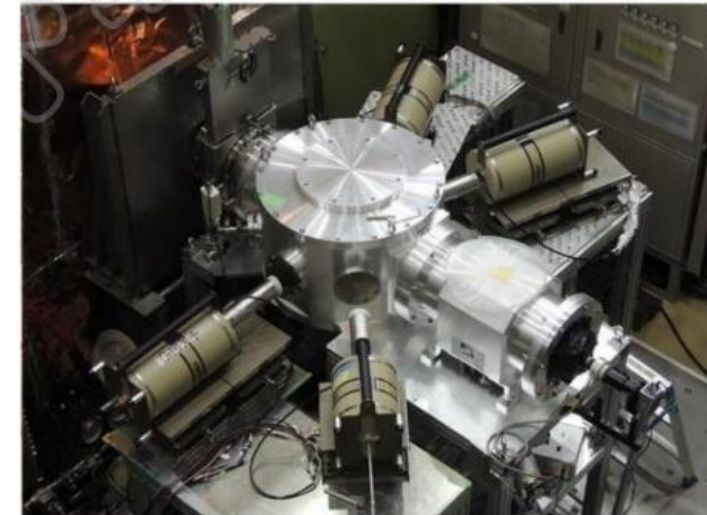

J-PARC HpGe array

MIXE Application

- ◆ Archeology
- ◆ Extraterrestrial samples
- ◆ Li battery
- ◆ ...

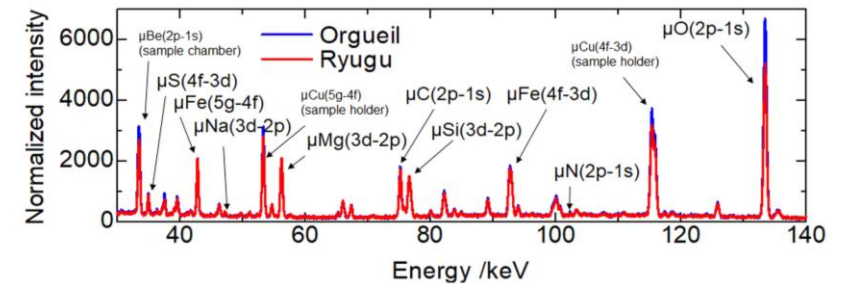
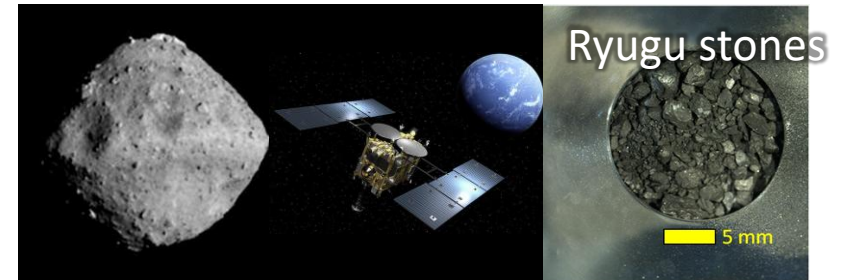
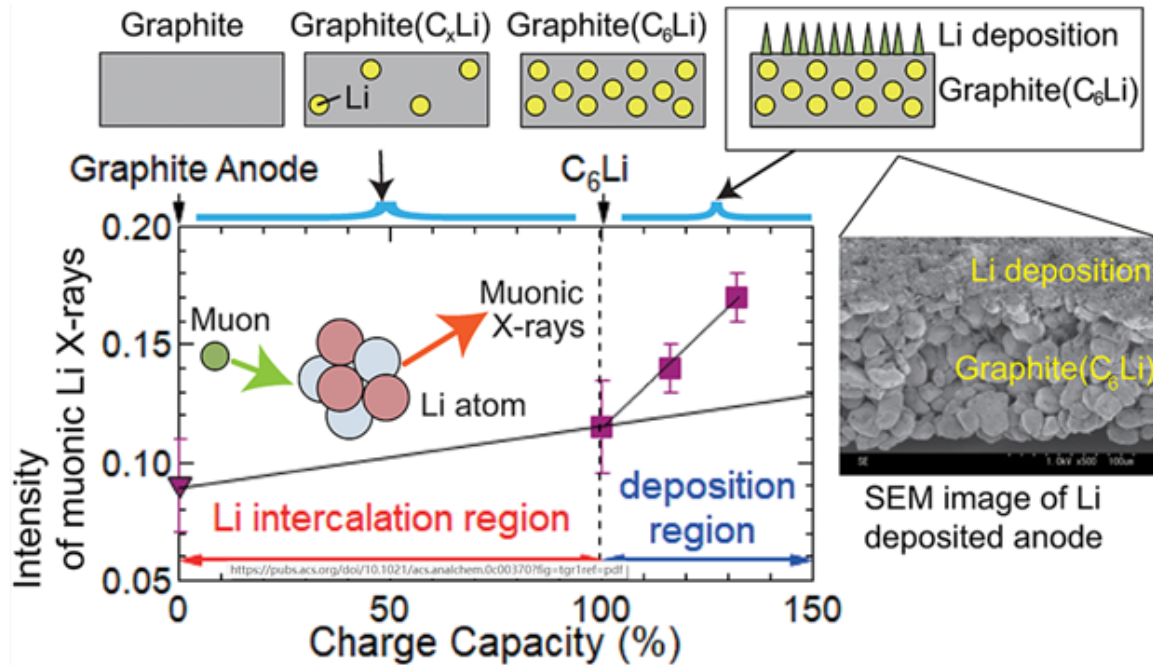
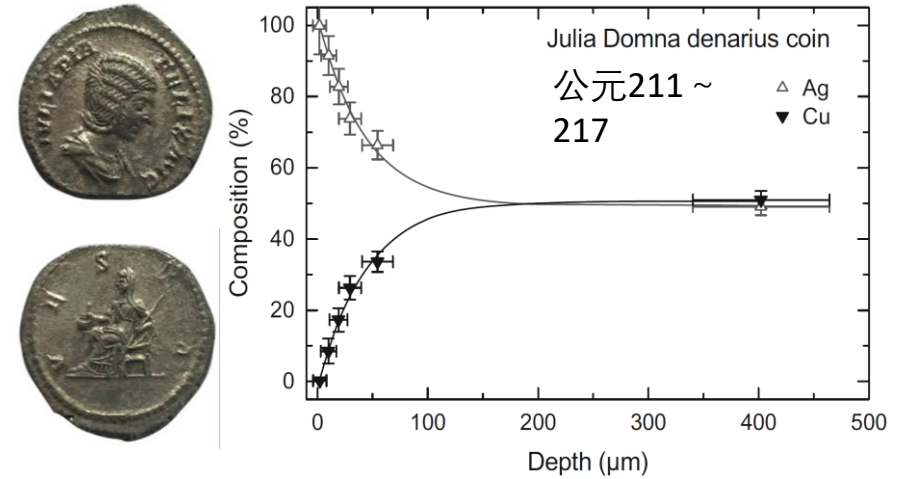

MIXE serves as a reliable solution for sample preservation across different operational environments

MIXE Imaging

◆ PSI: Continuous muon beam

- GEM-based TPCs are used to track the muons in the X-Y plane.
- The muon incident depth (Z) is calculated from the muon momentum.

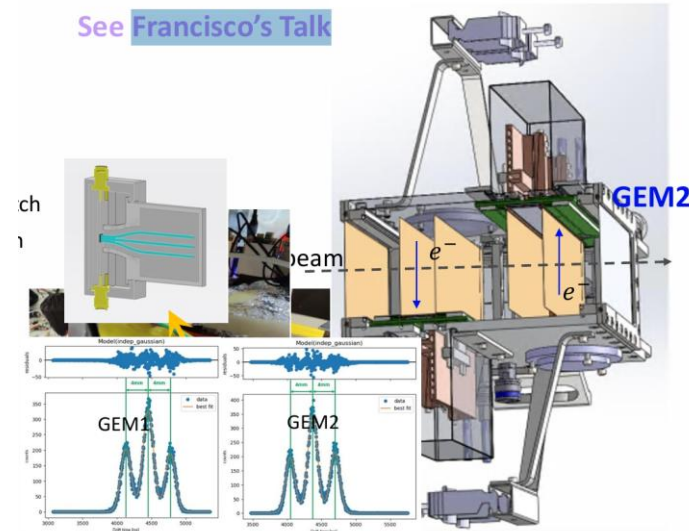

PSI MuX imaging technique

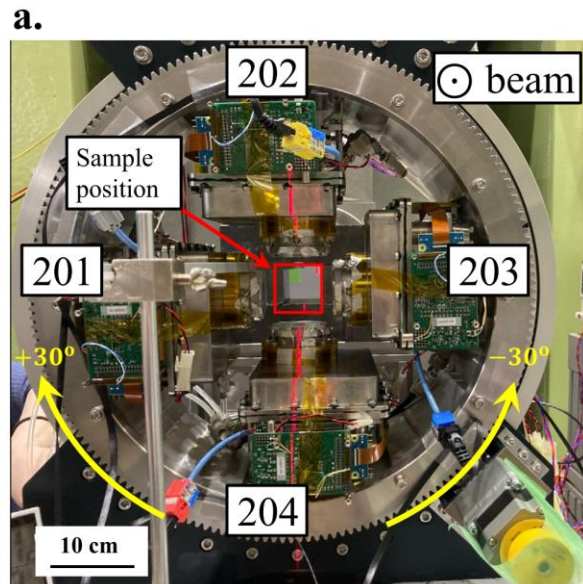

J-PARC imaging

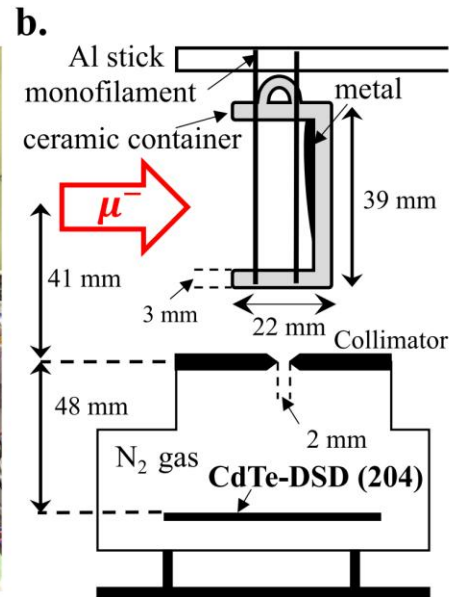

◆ J-PARC: Pulsed muon beam

- Pinhole imaging
- High spatial resolution is achieved through a small aperture collimator.
- 3D image reconstruction is performed using multi-angle scanning.

MIXE Imaging Application

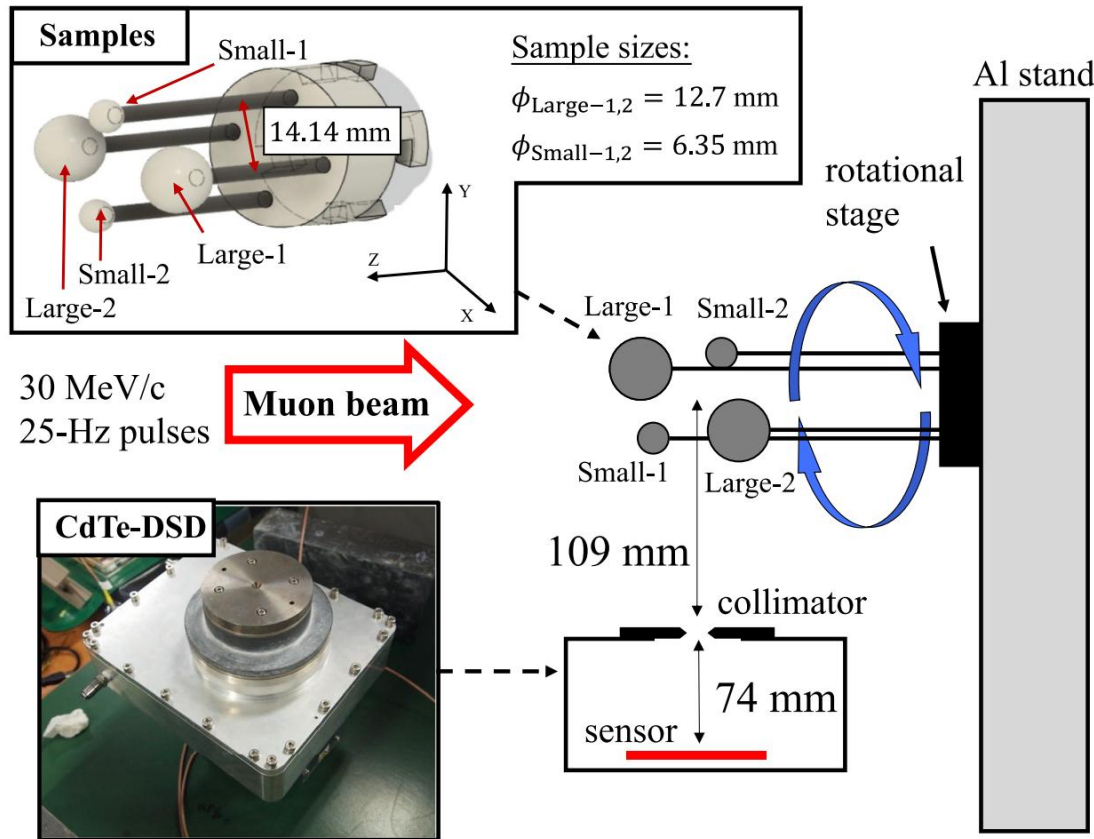

Figure 1. Geometry of the imaging experiment.

Chiu I H, Takeda S, Kajino M, et al. Non-destructive 3D imaging method using muonic X-rays and a CdTe double-sided strip detector[J]. Scientific Reports, 2022, 12(1): 5261.

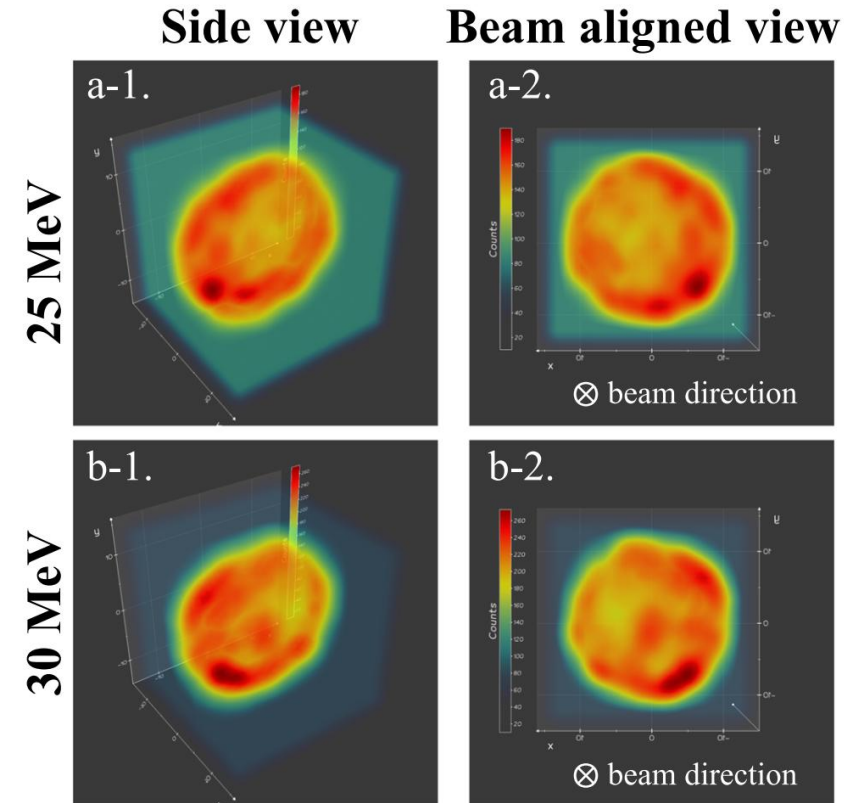

Fig. 9 | Side view (left) and beam-aligned view (right) of the reconstructed 3D phantom showing SiO_2 distribution at the crucible's bottom, as measured using muon momenta of 25 MeV/c(top) and 30 MeV/c(bottom).

Chiu I H, Osawa T, Ninomiya K, et al. Nondestructive 3D elemental imaging of Edo's archaeological artifacts via muonic X-ray measurements[J]. npj Heritage Science, 2025, 13(1): 154.

Outlines

- MELODY Beamlines
- MIXE Technique and Applications
- **MIXE Spectrometer for MELODY**
- Summary

Counting Rates of MIXE

◆ MELODY parameters:

- Repetition rate: 1 Hz
- Pulse width: ~120 ns
- Intensity: $10^5 \sim 10^6 \mu\text{-/pulse}$

◆ Detector requirement:

- Lower acceptance: reduce pile-up
- Higher granularity: Higher rates
- Hit num distribution: Poisson/unit
- Pile-up effect can be negligible at 0.3 hits/pulse (see table)

$$P(X = K) = \frac{\lambda^K e^{-\lambda}}{K!}$$

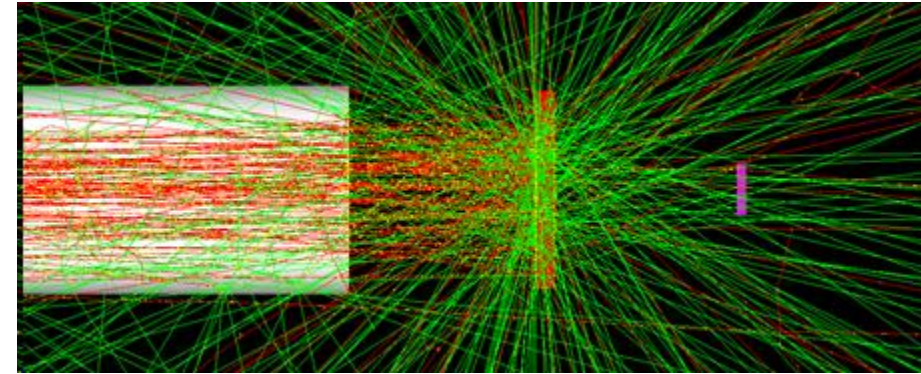

Average Hit Num (/unit)	1	0.5	0.3	0.1
P(X=0)	0.368	0.607	0.741	0.905
P(X=1)	0.368	0.304	0.222	0.091
P(X>1)	0.184	0.076	0.033	0.005

Pile-up effect in the MIXE spectrometer

- ◆ The counting rate of MIXE depends on the beam repetition rate and the number of detector units.

$$R = \lambda \square N_D \square f$$

MIXE Spectrometer for MELODY

- ◆ A funding (**Instrument Development Project**) from the **Chinese Academy of Sciences** to construct a MIXE spectrometer.

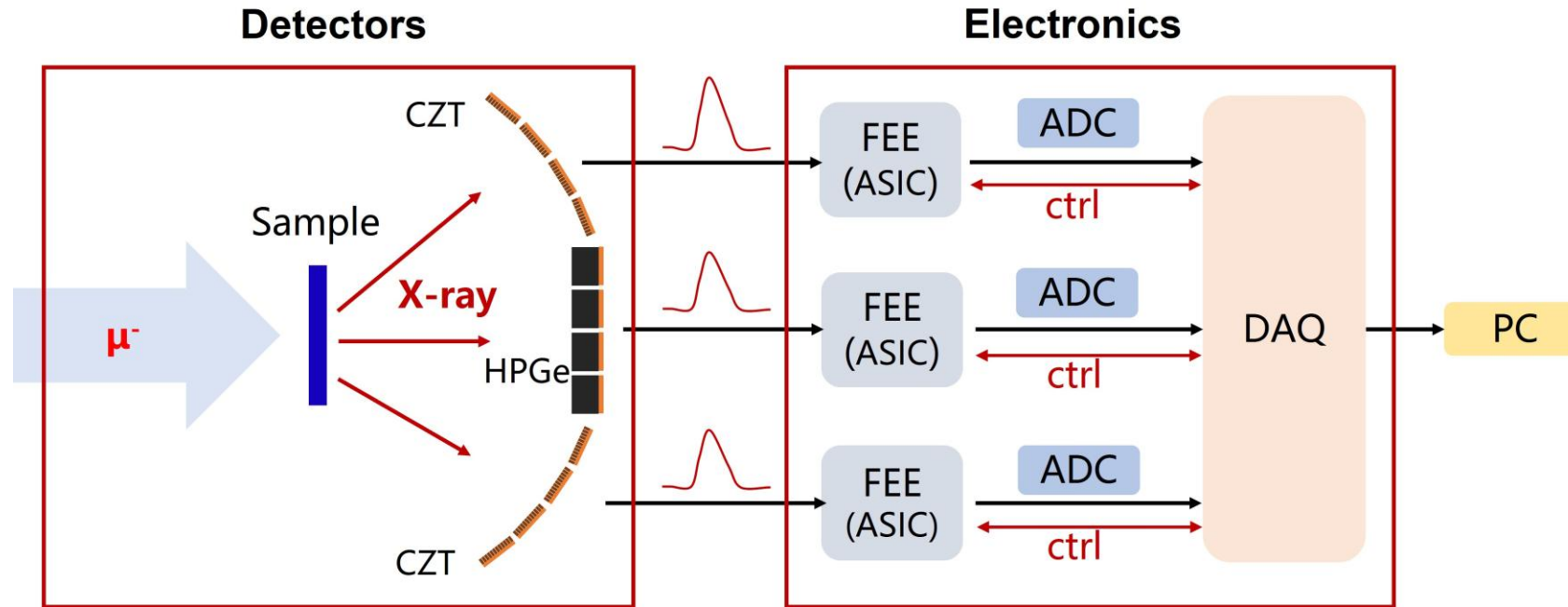

Schematic layout of the MIXE spectrometer designed for MELODY

- ◆ A hybrid MIXE spectrometer combining HPGe detectors and pixel-readout CZT (Cadmium Zinc Telluride) detectors was proposed.

MIXE spectrometer for MELODY

- ◆ Project period: 2026 to 2029, coinciding with the MELODY construction timeline.
- ◆ 4 HPGe detectors and 2000 channel CZT detector array.

	Items	Goal
MIXE spectrometer	Counting Rates	>200/pulse
CZT detector system	Channel	2000
	Energy Resolution	1.5%@662keV
HPGe detector	Units	4
	Energy Resolution	<0.3%@662keV

Parameters of the MIXE spectrometer designed for MELODY

HPGe Detector

- ◆ Provides accurate calibration of muonic X-ray peak positions.
 - Excellent resolution: 0.2% @1.33 MeV
 - Higher efficiency: 40% (1.33 MeV, ^{60}Co , 25 cm)

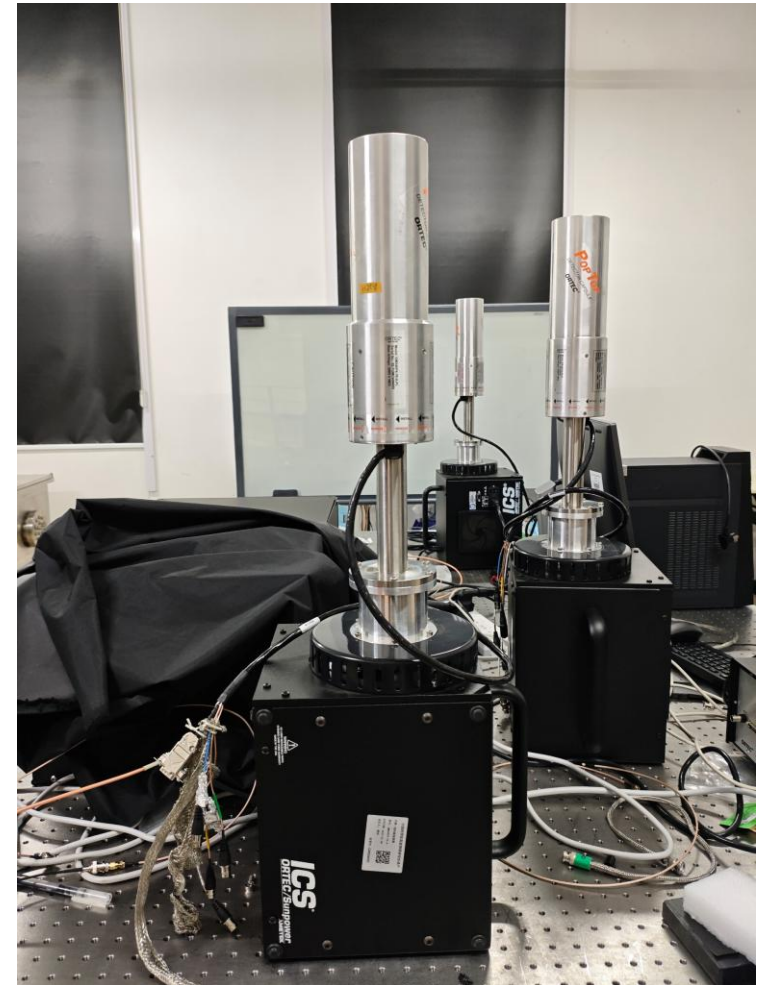
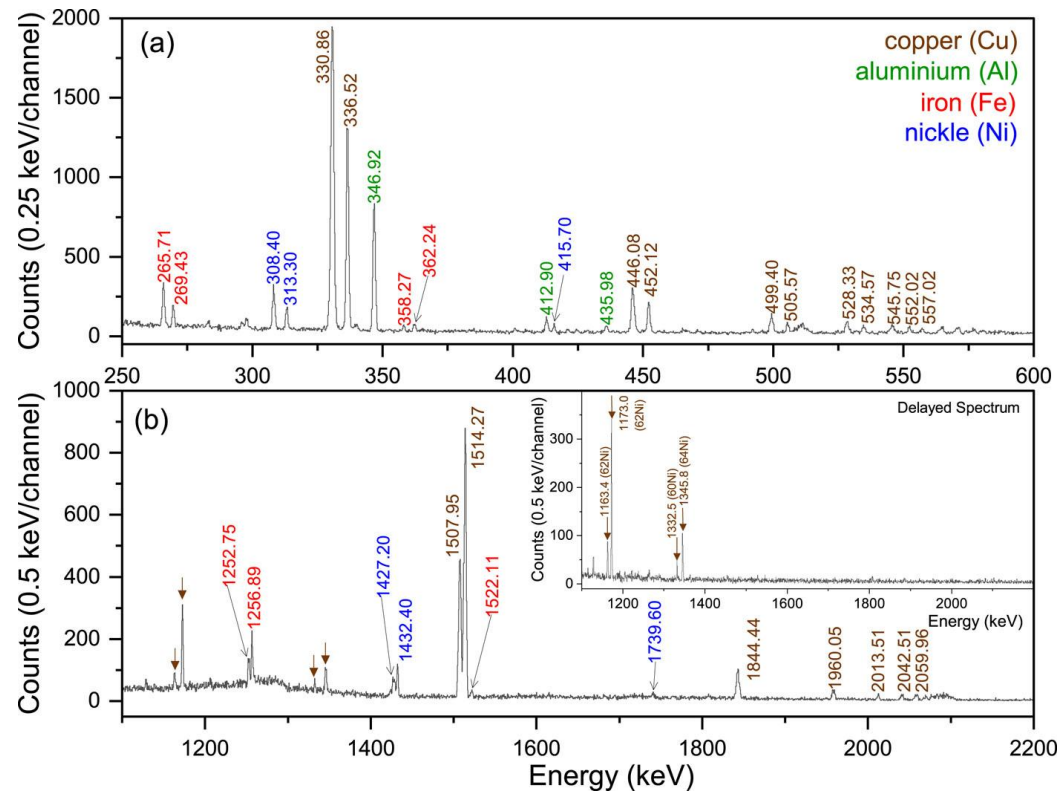

HPGe detector @Back-n CSNS

MIXE spectrometer for Aluminium bronze sample @PSI

CZT Detector

◆ CZT (Cadmium Zinc Telluride)

- Wide bandgap, room temperature operation
- Better energy resolution: low leakage current, small Fano factor
- High detection efficiency ($Z = 49$)

◆ Defects of CZT

- The hole mean free path is significantly shorter than that of electrons.
- The energy resolution is influenced by the incident depth of gamma rays.

◆ Ramo Theorem

$$Q_{induced} = q \cdot [\phi_w(b) - \phi_w(a)]$$

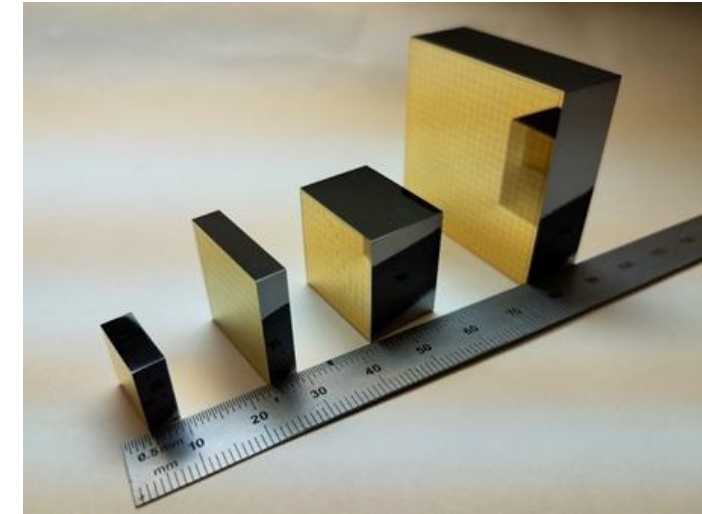

CZT Crystals

Crystal	density (g/cm ³)	Electron drift velocity (cm ² /V/s)	Hole drift velocity (cm ² /V/s)	Electron lifetime (s)	Hole lifetime (s)
CZT	5.78	1000	50	3×10⁻⁶	10⁻⁶
Ge	2.33	1400	480	>10 ⁻³	2×10 ⁻³
Si	5.33	3900	1900	>10 ⁻³	10 ⁻³

CZT, Ge, Si Parameters

Pixelated CZT

- ◆ **Small pixel effect:** Weighting field is strongly localized around the anode
- ◆ **Depth insensitivity:** Signal contribution of hole is much lower than electron.
- ◆ **Improved energy resolution:** reduced charge trapping effects
 - Pixel size: mm
 - Thickness: mm to cm
 - Energy resolution: $\sim 2\%$ @662keV

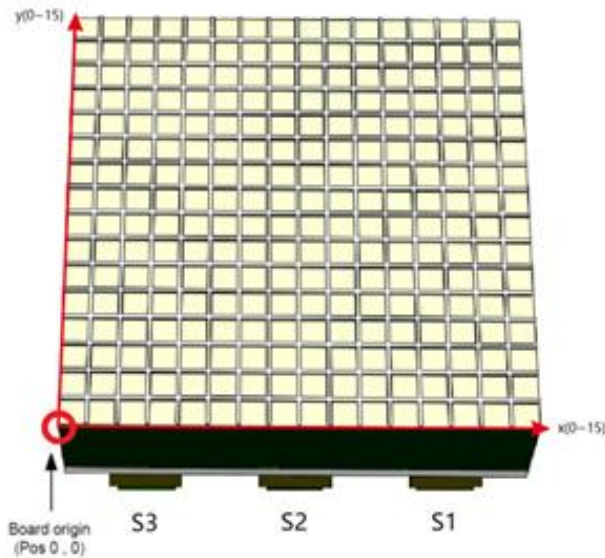
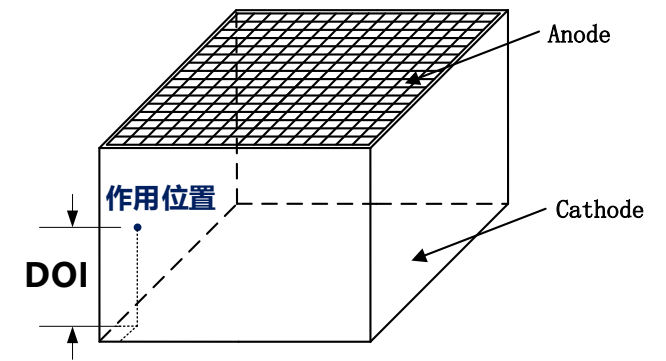

Pixelated CZT

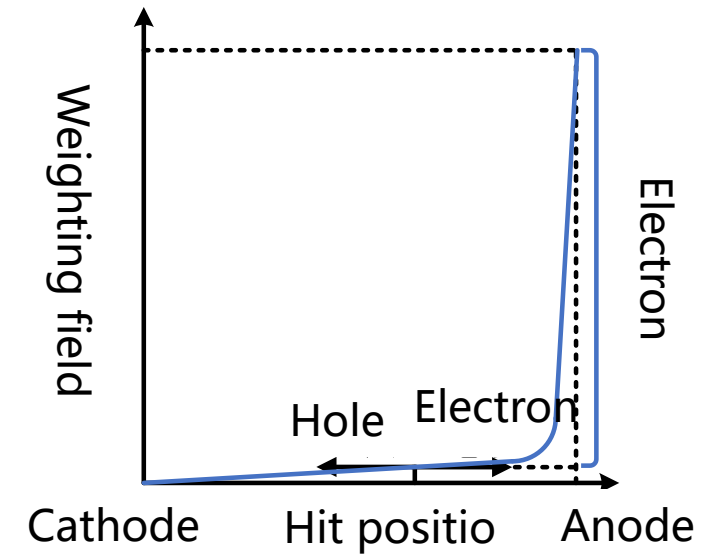
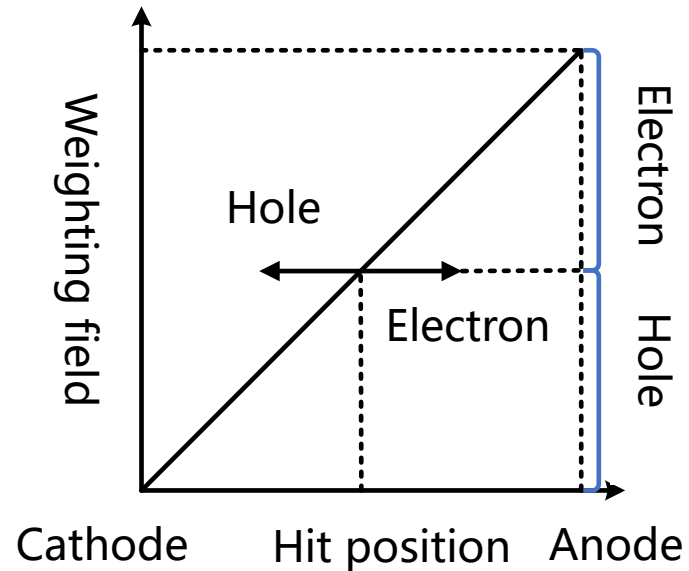

Weighting field of Plane-CZT and Pixel-CZT

CZT Detector Prototype

- ◆ In collaboration with USTC, a Pixel-CZT detector prototype was developed.
 - Two pixelated CZT detectors: produced by Redlen Technologies, $20 \times 20 \times 10 \text{ mm}^3$, 11×11 pixelated anode array with a pixel pitch of 1.72 mm.
 - Two signal readout electronic modules: Front-end module and Data Acquisition module
- ◆ Detector signals are amplified by ASIC chips, digitized by an FPGA, and the timing and amplitude information are saved.

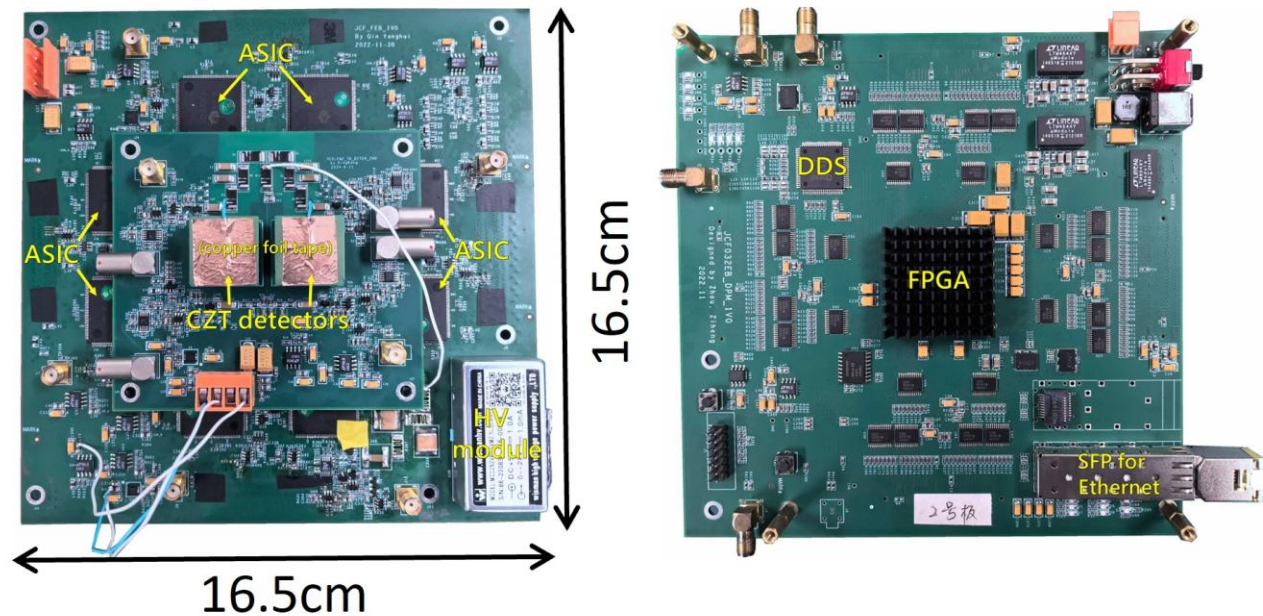
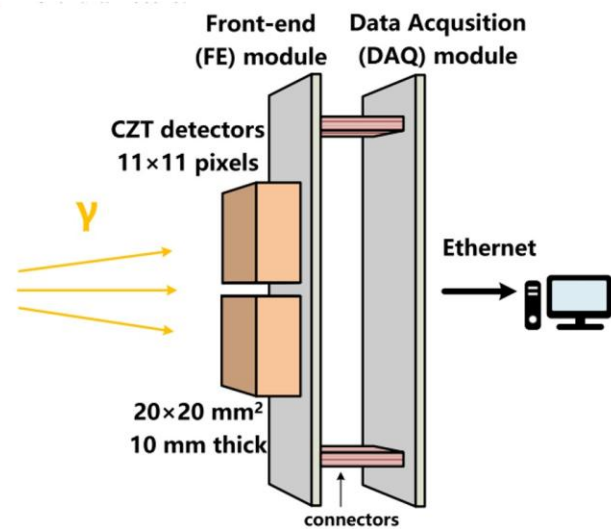

Pixel-CZT detector prototype

Zhou Z, Feng C, Qin Y, et al. A Prototype Gamma Imaging System for Measuring High-Intensity Proton Beam Spots Based on Pixelated CdZnTe Detectors[J]. IEEE Transactions on Nuclear Science, 2024, 72(3): 936-945.

Energy Resolution

- ◆ Energy spectrum with ^{137}Cs and ^{22}Na radioactive source
- ◆ The ratio of cathode to anode signals was used to determine the incident depth for energy resolution correction.
- ◆ Typical Resolution after correction: $\sim 1.2\%$

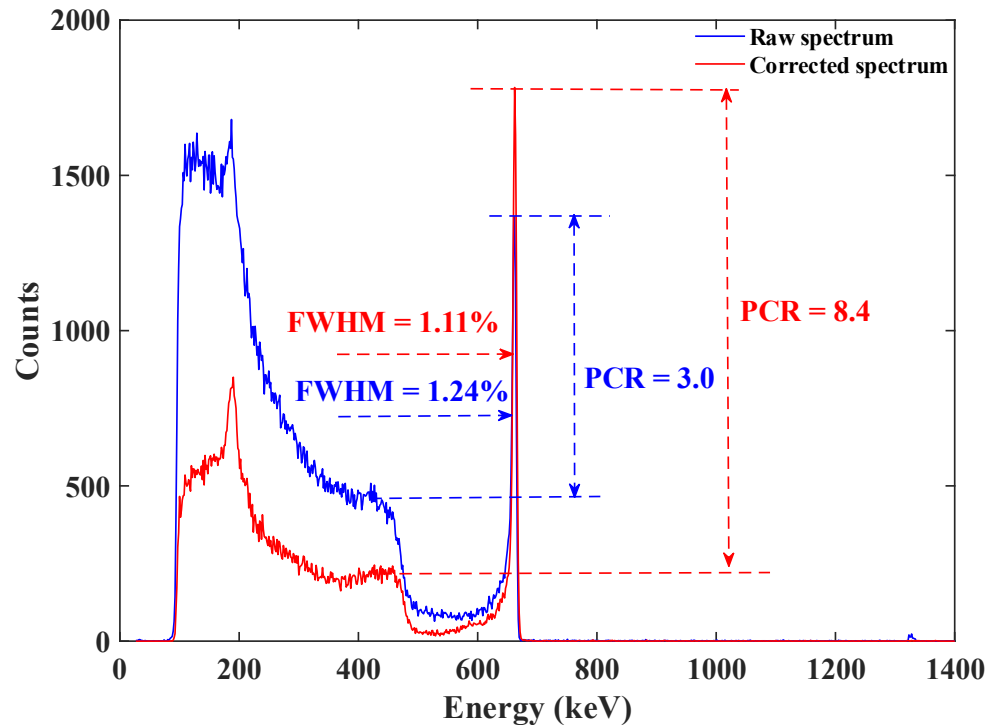

^{137}Cs source @662keV

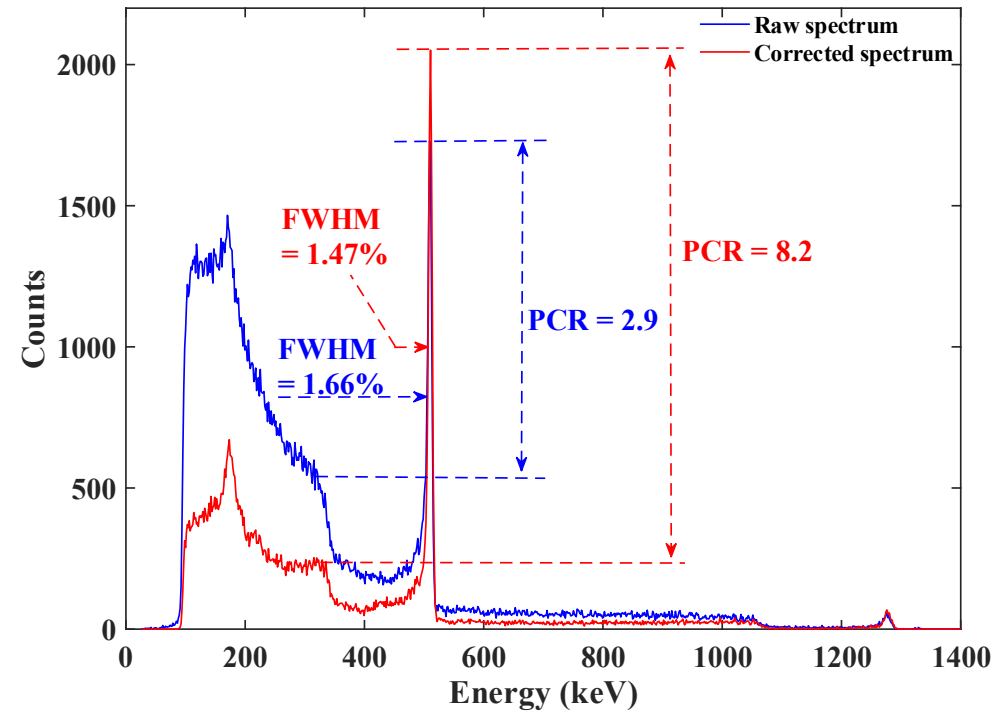

^{22}Na source @511keV

Uniformity

- ◆ Better resolution in central area, worse in the edge.
- ◆ The electronic routing scheme causes this resolution difference: longer signal traces for edge pixels introduce increased noise.
- ◆ We will improve the prototype design to optimize energy resolution.

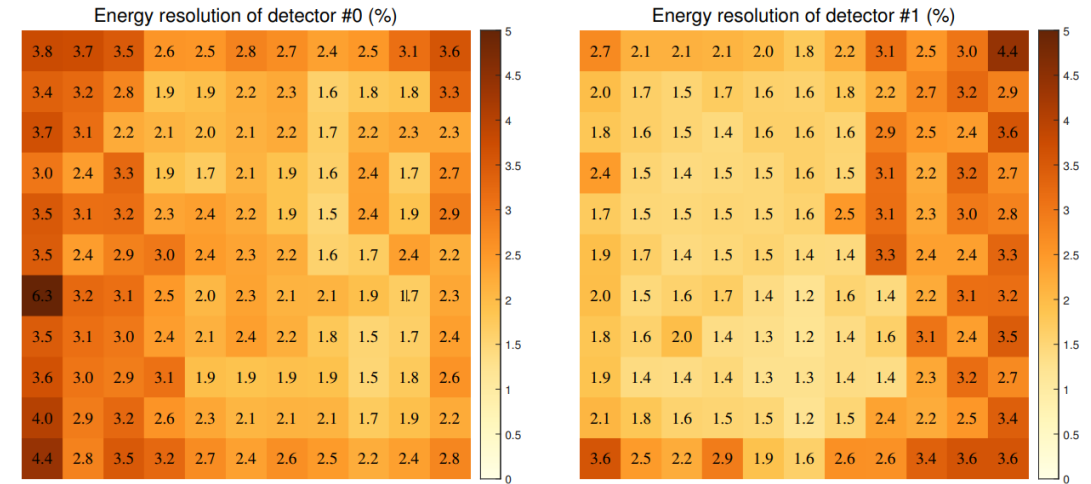

Before correction

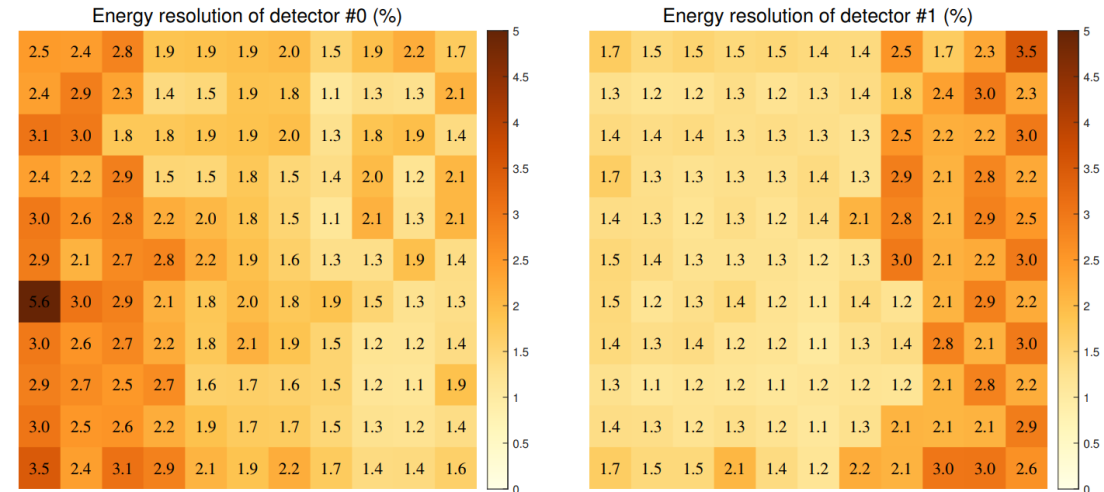

After correction

Pinhole Imaging Research

- ◆ The millimeter-scale position resolution offers significant potential for MIXE imaging.
- ◆ An imaging experiment was conducted at APEP CSNS for beam profile measurement.

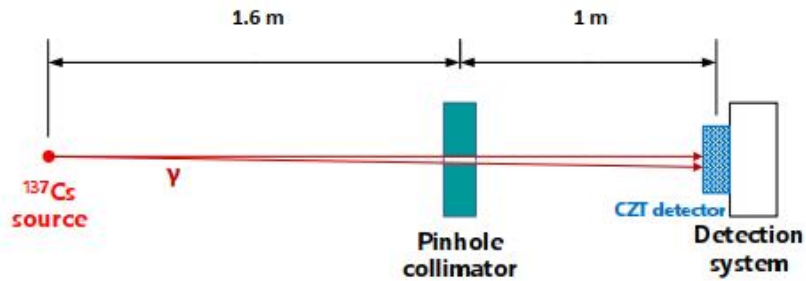

(a) Schematic of the imaging test



(b) Site photograph of the imaging test

Beam profile measured by screen

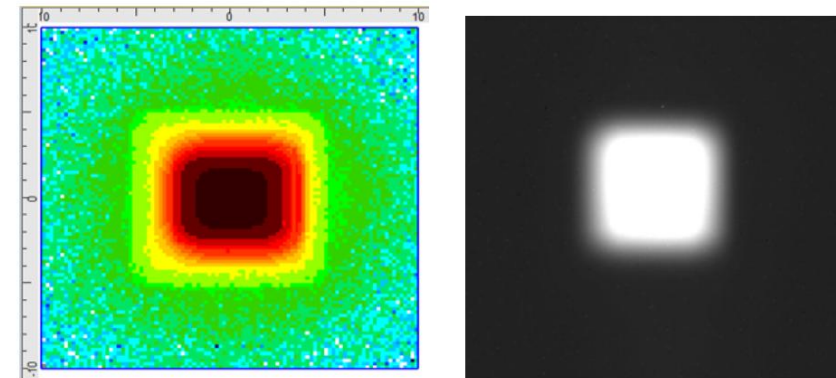

Beam profile measured by CZT @pinhole imaging

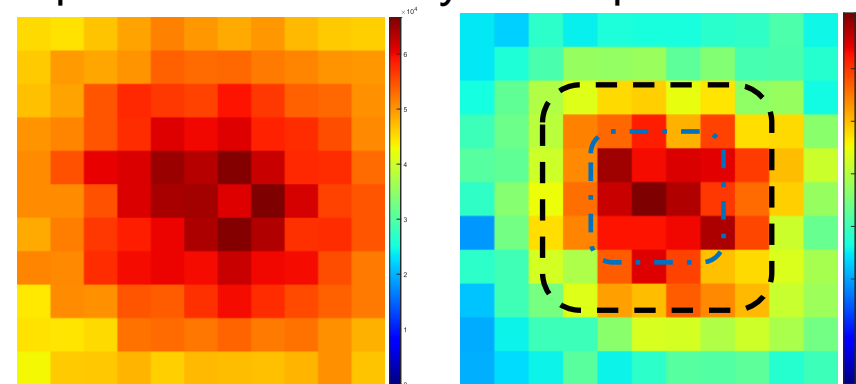

Zhou Z, Feng C, Qin Y, et al. A Prototype Gamma Imaging System for Measuring High-Intensity Proton Beam Spots Based on Pixelated CdZnTe Detectors[J]. IEEE Transactions on Nuclear Science, 2024, 72(3): 936-945.

Compton Imaging

- ◆ Compton MIXE imaging based on High pressure TPC and Pixel-CZT
- ◆ TPC: scattering detector, used to track the scattering electron.
- ◆ Pixel-CZT: absorbing detector, track the scattering photon.
- Collimator-Free.
- Higher imaging efficiency.
- 3D Imaging Capability

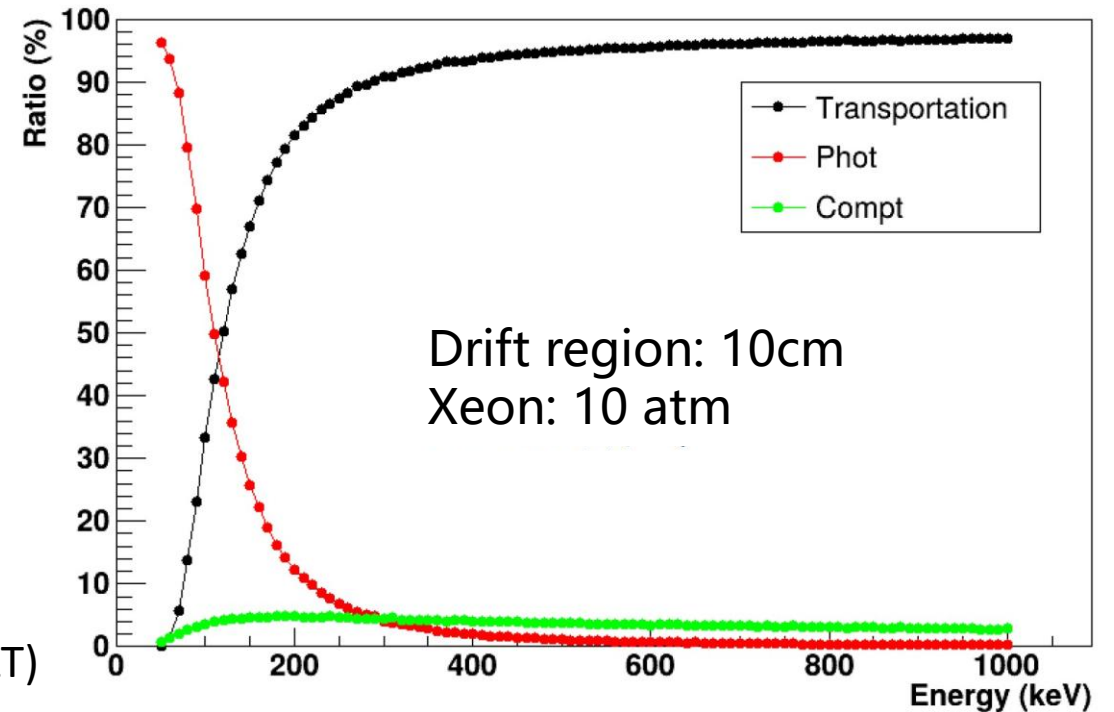
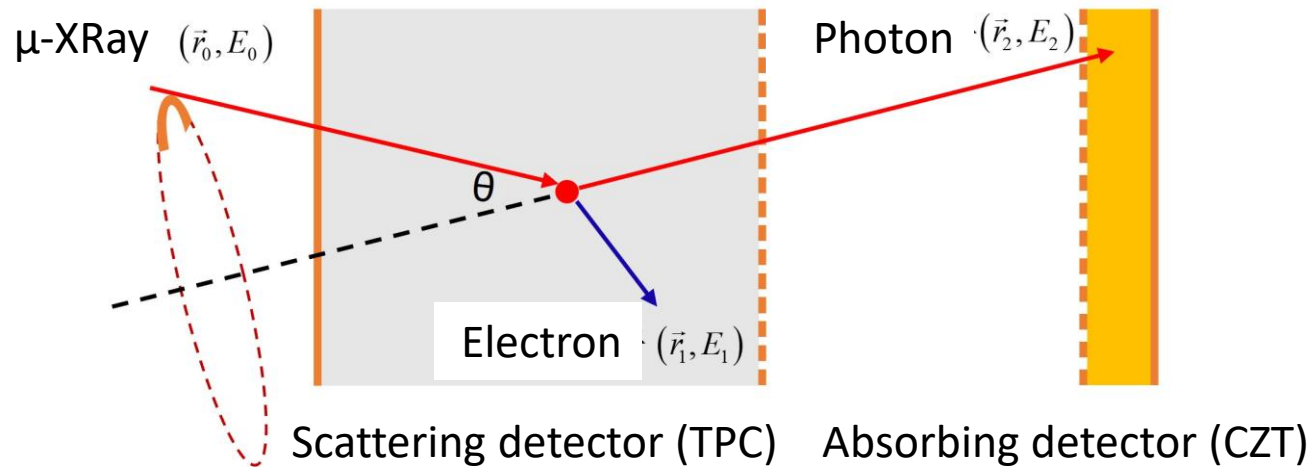

- ◆ μ -Xrays exhibit a larger Compton scattering cross-section in high-pressure TPCs.

Beam test plan

- ◆ In collaboration with the Palace Museum and the Xi'an Institute of Archaeology, we obtained beamtime at the PSI MuX terminal in August this year .
- ◆ We hope to bring the Pixel-CZT detector prototype to perform the beam test at the MuX.

Blue-and-White porcelain

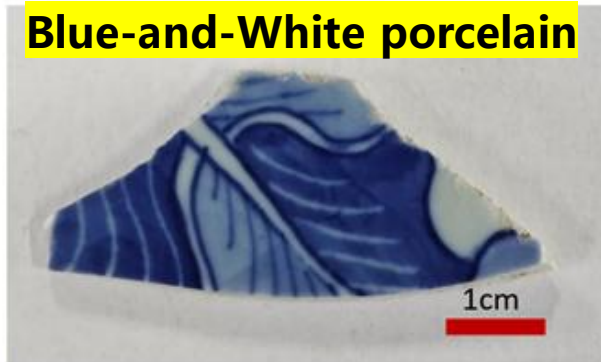

Please note that the overbooking factors for all the instruments were again very high (up to 3.6) for this round. Even though quite an important portion of the beamtime usually reserved for commissioning and developments was exceptionally allocated to external users, the overbooking situation has led to an important proposal rejection or cuts of the beamtime allocation.

Proposal	20251248
Instrument	GIANT/MIXE
Title	Quantitative Analysis of Elements in Chinese Blue-and-White Porcelain by MIXE
Requested	3 Shifts on GIANT/MIXE
Allocated	3 Shifts
Scheduled	30 AUG 2026 16:00 - 31 AUG 2026 00:00 (1 Shift) 31 AUG 2026 00:00 - 31 AUG 2026 16:00 (2 Shifts)
Pgroup	p23174
Status	Accepted

(a) Song Dynasty Iron Coins



Please note that the overbooking factors for all the instruments were again very high (up to 3.6) for this round. Even though quite an important portion of the beamtime usually reserved for commissioning and developments was exceptionally allocated to external users, the overbooking situation has led to an important proposal rejection or cuts of the beamtime allocation.

Proposal	20251251
Instrument	GIANT/MIXE
Title	Elemental Analysis of Northern Song Dynasty Iron Coins using MIXE
Requested	2 Shift on GIANT/MIXE
Allocated	1 Shift
Scheduled	30 AUG 2026 08:00 - 30 AUG 2026 16:00 (1 Shift)
Pgroup	p23176
Status	Accepted

Comments of the proposal review committee:

Summary

1. MELODY is currently under construction and is expected to deliver both **surface muon beams** and **negative muon beams by 2029**.
2. We have **received funding from the Chinese Academy of Sciences** to construct a MIXE spectrometer in China. Based on the MELODY beamline, a **hybrid MIXE spectrometer** combining HPGe detectors and pixel-CZT detectors has been proposed and designed.
3. A **pixel-CZT detector prototype** was developed and tested with radioactive sources in the laboratory, achieving an energy resolution of better than 1.2% at 662 keV.
4. The MIXE spectrometer is **scheduled for completion by 2029**, and then the MIXE experiment will be conducted at MELODY.