

International
Muon Collider
Collaboration



MuCol

Muon Collider

D. Schulte

On behalf of the International Muon Collider Collaboration

MIP2026, Huizhou, April, 2026



Funded by the European Union (EU). Views and opinions expressed are however those of the author(s) only and do not necessarily reflect those of the EU or European Research Executive Agency (REA). Neither the EU nor the REA can be held responsible for them.

Muon Collider Concept

The main challenge is the short muon lifetime $\tau = \gamma \times 2.2 \mu\text{s}$
Up to 100 ms at collision energy

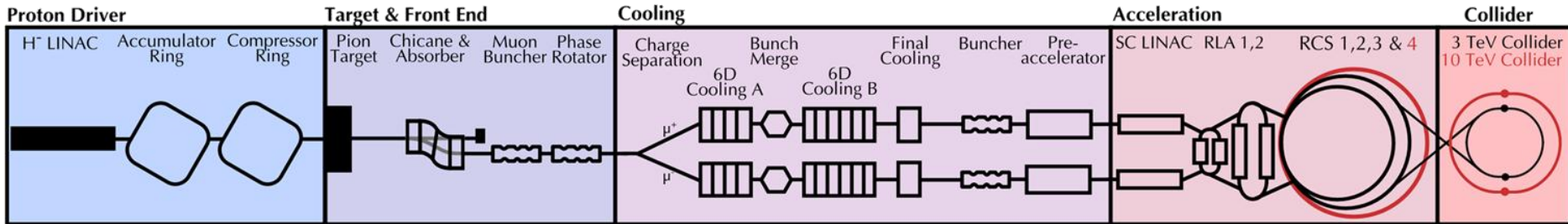

Short, intense
proton bunch

Protons produce
pions which decay
into muons which are
captured

Ionisation cooling of
muon in matter

Acceleration to
collision energy

Collision

IMCC

International Muon Collider Collaboration



Develop high-energy muon collider as option for particle physics:

- Implement globally defined accelerator R&D roadmap to justify CDR phase
- Mid-term roadmap review found 75% of goal achieved

Focus on feasibility of **10 TeV with 10 ab⁻¹** (site independent)

- Explore **initial stage by around 2050**, maybe with 3 TeV with 1 ab⁻¹ or lower luminosity 10 TeV

Explore implementation at specific sites reusing infrastructure

Provided ESPPU with

- **Assessment of muon collider**
- An **R&D plan** for the next 10 years
- **Implementation considerations** (including site, timeline, ...)
- **Back-up document** (406p, 450 signatories)

In US the National Lab Accelerator Study Group for the Muon Collider identifies how the US labs can best engage

Param.	Unit	3 TeV	10 TeV
L/IP	10 ³⁴ cm ⁻² s ⁻¹	1.8	17.5
N	10 ¹²	2.2	1.8
f _r	Hz	5	5
C	km	4.5	11.4
B _{dipole}	T	11	14
Collider techn.		Nb3Sn	HTS

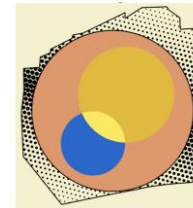

IMCC Partners



IEIO	CERN
FR	CEA-IRFU
	CNRS-LNCMI
	<i>Ecoles des Mines St-Etienne</i>
DE	DESY
	Technical University of Darmstadt
	University of Rostock
	KIT
UK	RAL
	UK Research and Innovation
	University of Lancaster
	University of Southampton
	University of Strathclyde
	University of Sussex
	Imperial College London
	Royal Holloway
	University of Huddersfield
	University of Oxford
	University of Warwick
	University of Durham
	University of Birmingham
	<i>University of Cambridge</i>
NL	University of Twente

IT	INFN
	INFN, Univ., Polit. Torino
	INFN, LASA, Univ. Milano
	INFN, Univ. Padova
	INFN, Univ. Pavia
	INFN, Univ. Bologna
	INFN Trieste
	INFN, Univ. Bari
	INFN, Univ. Roma 1
	<i>ENEA</i>
	INFN Frascati
	INFN, Univ. Ferrara
	INFN, Univ. Roma 3
	INFN Legnaro
	INFN, Univ. Milano Bicocca
	INFN Genova
	INFN Laboratori del Sud
	INFN Napoli
Mal	Univ. of Malta
EST	Tartu University
PT	LIP
SE	ESS
	University of Uppsala

FI	Tampere University
	<i>HIP, University of Helsinki</i>
LAT	Riga Technical University
CH	PSI
	University of Geneva
	EPFL
	HEIA-FR
BE	Univ. Louvain
AU	HEPHY
	TU Wien
ES	I3M
	<i>IFIC/CSIC</i>
	ICMAB
China	<i>Sun Yat-sen University</i>
	IHEP
	Peking University
	Inst. Of Mod. Physics, CAS
	University of CAS
KO	Kyungpook National University
	Yonsei University
	Seoul National University
India	CHEP

Signed MoC (61), requested MoC, contributor

CA	Université Laval
US	Iowa State University
	University of Iowa
	Wisconsin-Madison
	<i>University of Pittsburgh</i>
	Old Dominion
	Chicago University
	Florida State University
	RICE University
	Tennessee University
	<i>MIT Plasma science center</i>
	Pittsburgh PAC
	Yale
	<i>Princeton</i>
	Stony Brook
	Stanford/SLAC
	...
DoE labs	FNAL
	LBNL
	JLAB
	BNL
Brazil	CNPEN

Physics Case for Leptons at 10 TeV



Physics case is pointed out in many places, just one example from last year:

National Academy of Science

A collider with approximately **10 times the energy of the Large Hadron Collider (LHC)** is crucial for addressing the big questions of particle physics and making discoveries.

A **10-TeV muon collider** on the Fermi National Accelerator Laboratory (Fermilab) site would have **similar discovery reach as a 100-TeV proton collider**.

A muon collider combines the physics **advantages** of an **electron-positron** and a **proton-proton collider**, with a **much smaller size**.

Strong physics case complementary to FCC-ee + FCC-hh exists, see for example Snowmass and NAS report

M. Spiropulu (*Co-Chair*), M. S. Turner (*Co-Chair*), N. Arkani-Hamed, B. C. Barish, J. F. Beacom, PH. H. Bucksbaum, M. Carena, B. Fleming, F. Gianotti, D. J. Gross, S. Habib, Y.-K. Kim, P. J. Oddone, J. R. Patterson, F. Pilat, C. Prescod-Weinstein, N. Roe, T. M.P. Tait,
Staff: T. Konchady, D. Nagasawa, L. Walker, D. Wise, C. N. Hartman, A. Mozhi

Muon Collider Target Parameters

Requires emittance preservation and advanced lattice design

$$\mathcal{L} \propto \gamma \langle B \rangle \sigma_\delta \frac{N_0}{\epsilon \epsilon_L} f_r N_0 \gamma$$

High energy \rightarrow γ
 High field in collider ring \rightarrow $\langle B \rangle$
 Large energy acceptance \rightarrow σ_δ
 Dense beam \rightarrow N_0
 High beam power \rightarrow $f_r N_0 \gamma$

Param.	Unit	Site independent	
Sqrt(s)	TeV	3	10
Int L	ab ⁻¹	1	10
L/IP	10 ³⁴ cm ⁻² s ⁻¹	1.8	17.5
Acc. time	years	2+2.8	2+2.9

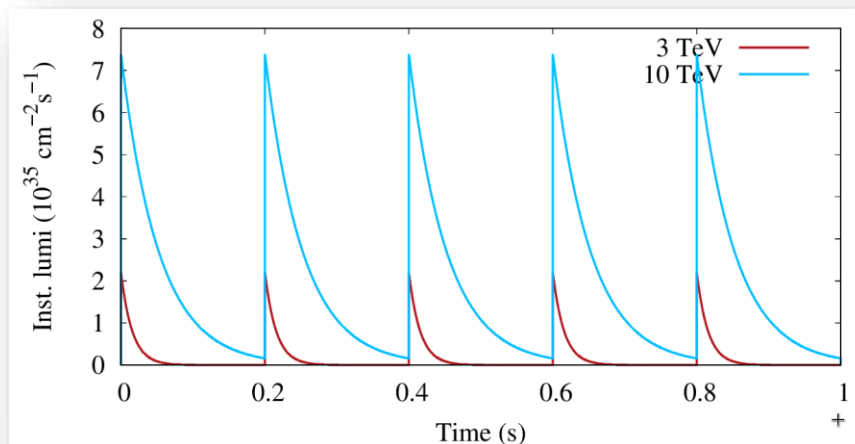
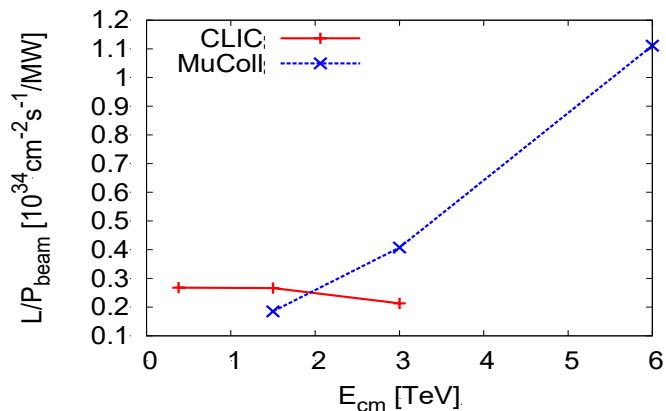

Muon Beam Production and Transmission



Subsystem	Energy GeV	Length m	Achieved Transm. %	Achieved μ^- /bunch 10^{12}	Target μ^- /bunch 10^{12}
Proton Driver	5 (p^+)	1500	–	500 (p^+)	
Front End	0.17	150	9	45.0	
Charge Sep.	0.17	12	95	42.8	
Rectilinear A	0.14	363	50	21.4	
Bunch Merge	0.12	134	78	16.7	
Rectilinear B	0.14	424	32	5.3	
Final Cooling	0.005	100	60	3.2	
Pre-Acc.	0.25	140	86	2.8	4.0
Low-Energy Acc.	5	–	90*	2.5	
RLA2	62.5	o2430	90	2.3	
RCS1	314	o5990	90	2.1	
RCS2	750	o5990	90	1.9	
RCS3	1500	o10700	90	1.7	
3 TeV Collider	1500	o4500	–	1.7	2.2
RCS4	5000	o35000	90	1.5	
10 TeV Collider	5000	o10000	–	1.5	1.8

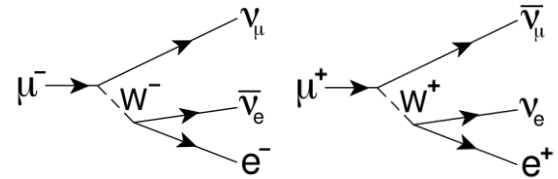

Need to produce many muons

Efficient muon transport is key to the luminosity

- Need to have compact cooling system
- Need fast acceleration

Need some improvement in muon production or in transport

- Being studied

Note: μ^+ can be 30% higher

Muon Collider CTEs

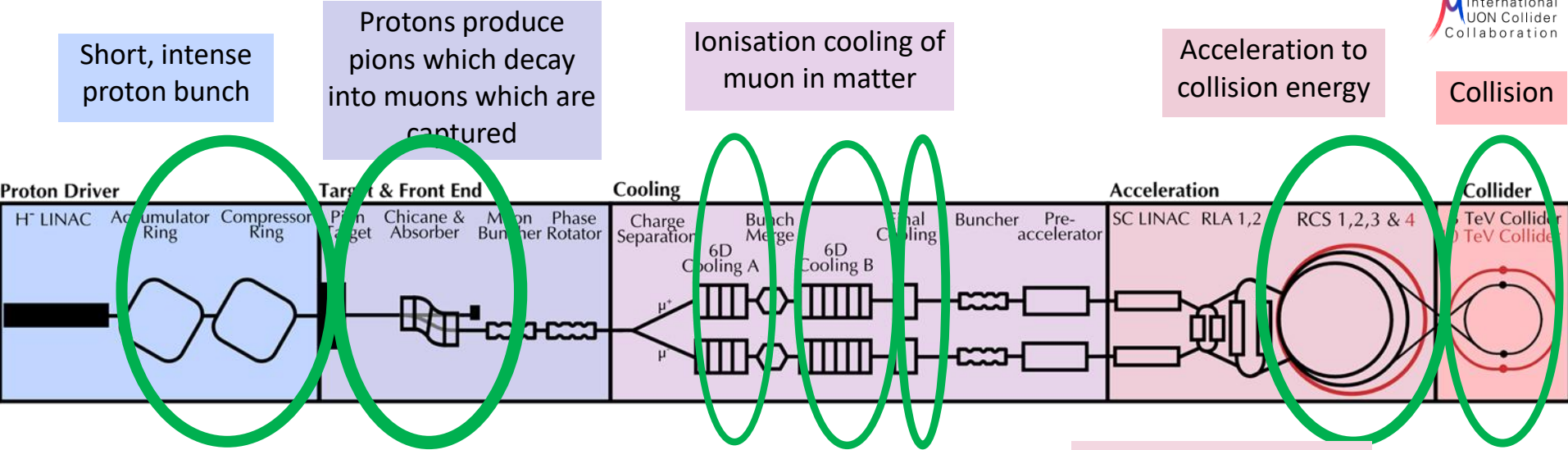

Short, intense proton bunch

Protons produce pions which decay into muons which are captured

Ionisation cooling of muon in matter

Acceleration to collision energy

Collision

- Proton pulse accumulation and compression

- Graphite target
- Target solenoid

- Muon cooling design
- 6D cooling solenoids
- 6D cooling RF cavities
- Final cooling solenoids

- Pulsed magnets and power converters
- RCS RF system

- Collider ring dipoles
- Final focus quadrupoles
- Machine-detector interface
- Neutrino flux

Identified and prioritized with community
Other areas need now also to be addressed
(some work started)

Physics and Detector Concepts

Challenges:

Muon decay can give important background

- 40 000 muons/m/bunch crossing
- 1/3 of energy in electrons and positrons

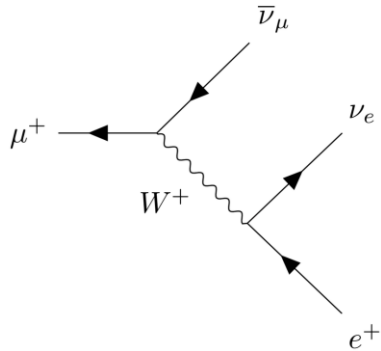

MUSIC

(MUon Smasher for Interesting Collisions)

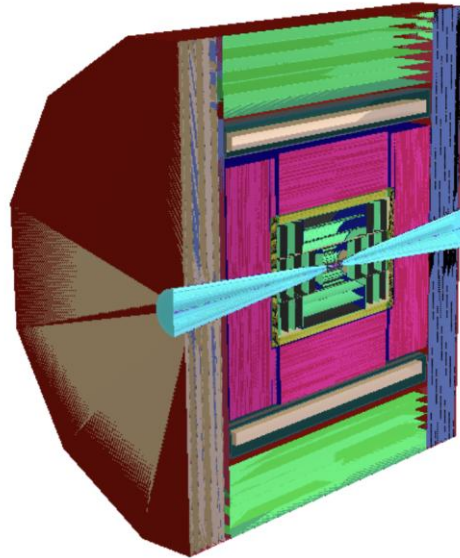

MAIA

(Muon Accelerator Instrumented Apparatus)

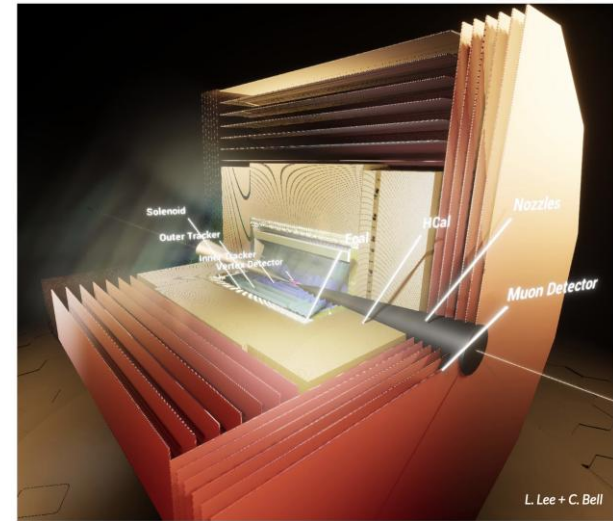

Two detector concepts are being developed

Beam-induced Background

Achievements:

- Two conceptual detector designs
- Simulation studies with background also from machine
- Studies of different lattices
- Reconstruction algorithms
- Physics studies

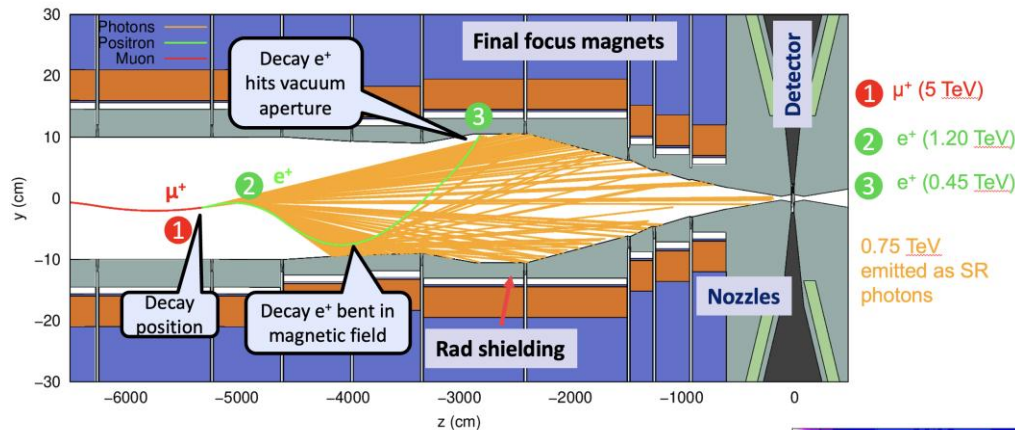

Detailed studies with FLUKA

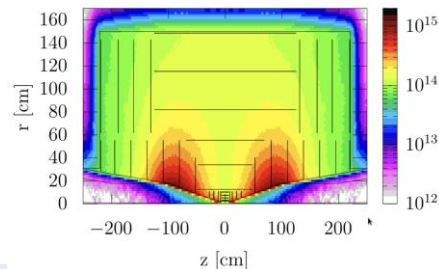
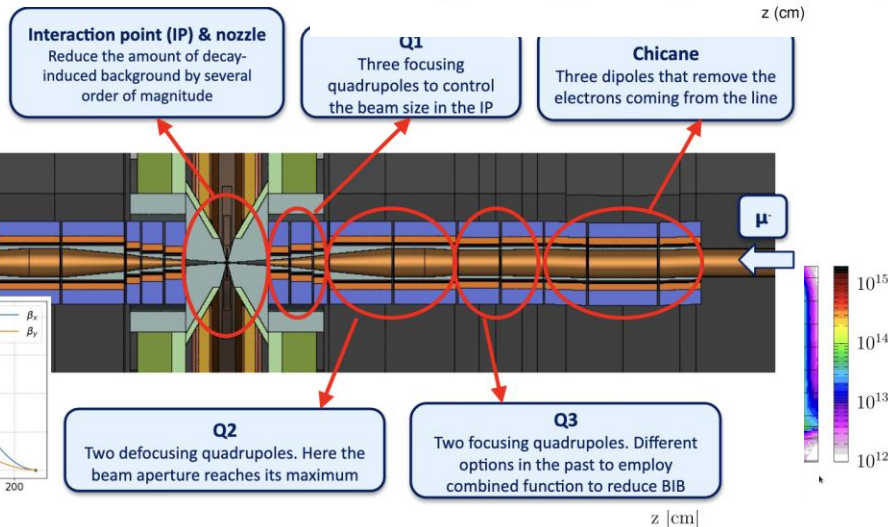

Conclusions:

- Can do the physics
 - Also thanks to HL-LHC technology
- But room for improvement
- Radiation level similar to HL-LHC

Proton Complex



International
UON Collider
Laboratory

Challenge:

- 2 MW, 5 GeV, 5 Hz,
- 5×10^{14} protons/pulse
- Proton pulse accumulator and compressor rings

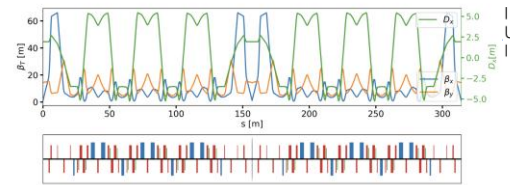
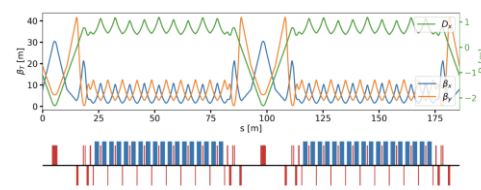
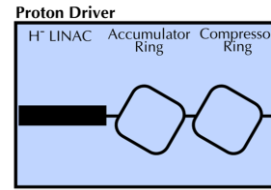

Achieved:

- Accumulator and combiner ring lattices
- First collective effects studies promising
- One or two bunches in compressor, to be decided

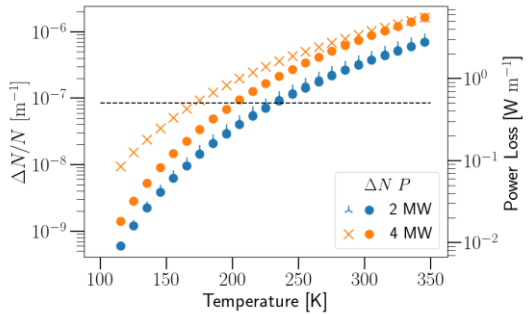
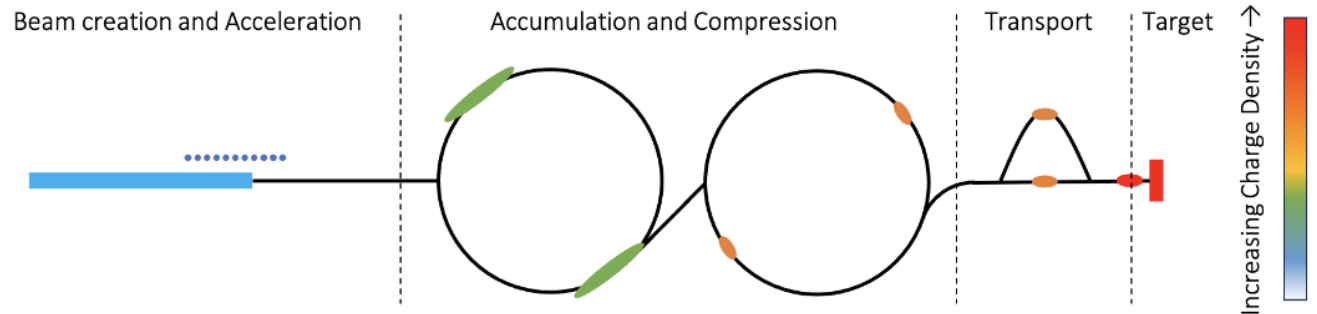

Power Loss [W m⁻¹]

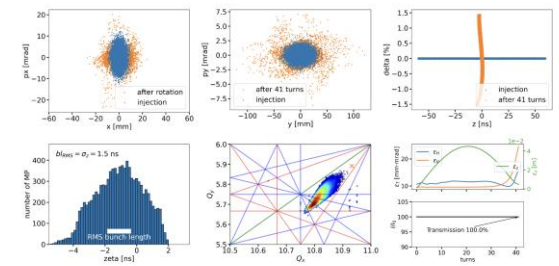

Fig. 5.1.8: Simulation of the full compression for one bunch at 5 GeV. Since this requires a 2 bunch solution scheme, this bunch has half of the full intensity shown in Table 5.1.1. Notice that at the end of the compression there is still some emittance blow up that need still to be addressed.

Key conclusions:

- Can compress 2 MW, 5 GeV proton beam to two 2 ns bunches, then merge them
 - Optimisation in compressor ring for collective effects ongoing
- For 4 MW need 10 GeV beam
- Cool beamline to avoid ion loss from black body radiation

Target



Challenges:

- 2 MW, 5 Hz, 400 MJ/pulse target
- Can we replace mercury with graphite?

Achieved:

- Initial 2 MW graphite target conceptual design, pion yield optimised
- HTS solenoid and shielding concept developed
- Study of proton removal ongoing

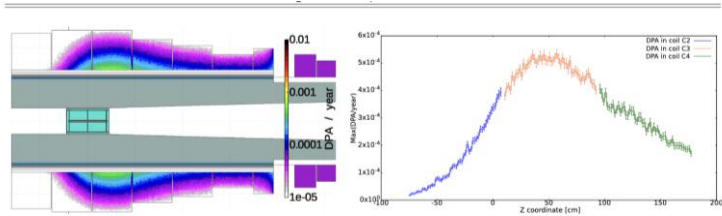
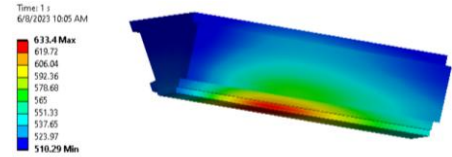
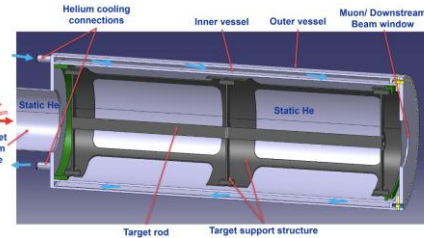
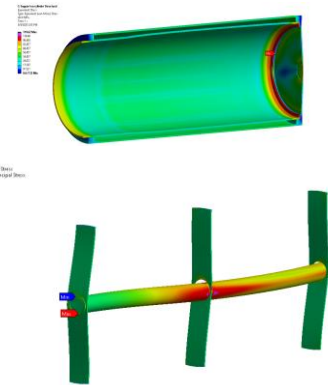
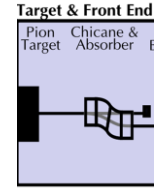
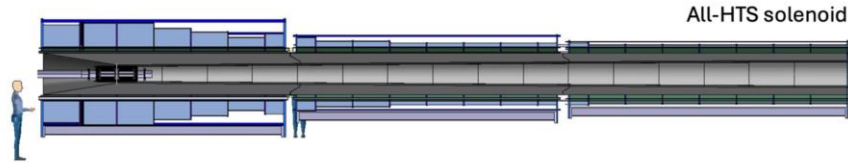

Fig. 6.5.1: 2D map of the displacement per atom (DPA) in the superconducting magnets of the target area (left) and the peak DPA in the coils most exposed to radiation (right).

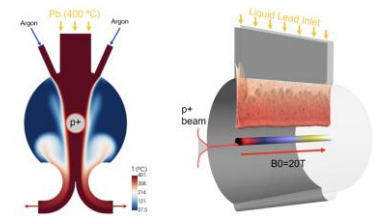

Fig. 6.4.4: Liquid lead target curtain concept.

Key conclusions:

- Yield, magnet shielding, target stress, cooling, radiation are OK
- Components survive 2 MW beam
- Higher power alternatives to study:
 - Graphite
 - Liquid metal

Note: High-field Magnet Technology

NbTi (niob-titanium, operating at 2-4 k)

- is standard, **used in LHC**
- Expect 5 T in MC

Nb₃Sn (niobium-tin, operating at 2-4 K)

- Expect O(11 T) in MC
- Still not mature
- Used in some points for HL-LHC
- Foreseen for FCC-hh also in arcs

HTS (high-temperature superconductor, operating up to 20 K)

- Different options exist, e.g. REBCO
- In solenoids > 30 T demonstrated
- Still expensive and technology challenges
- Applications in other fields, e.g. medical, fusion reactors, power generators for wind energy, engines, ...

REBCO Tape

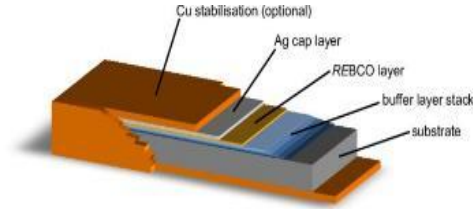

HTS cost is coming down
How much depends on the
overall use of HTS

Nb3Sn cost slowly increasing
We may be the only users
Industry would have to ramp
up just for us

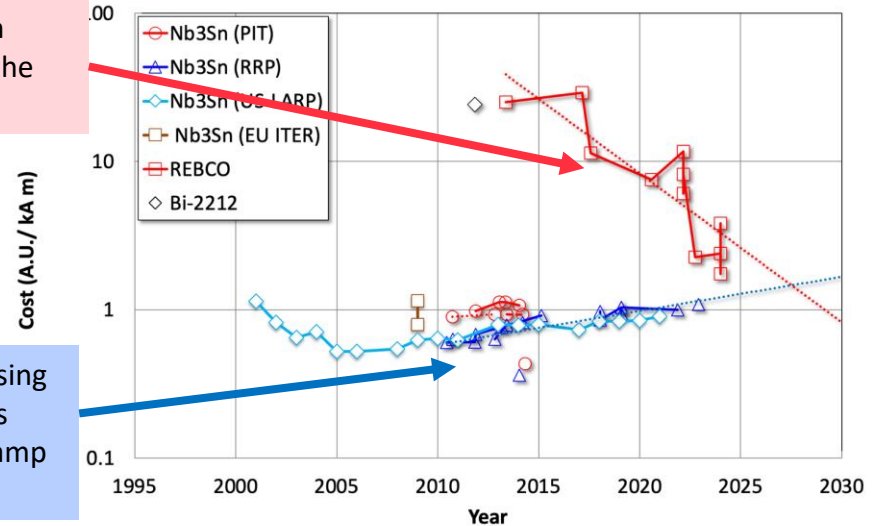

Muon Cooling Lattice Design

Challenge:

Novel, complex lattice with cavities and absorbers in solenoids

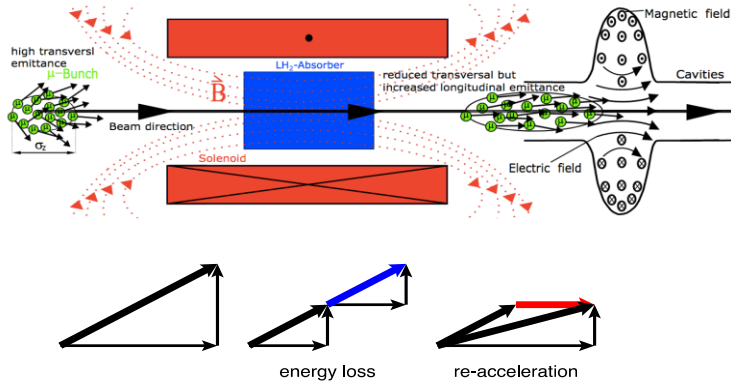

Achieved:

Much improved lattice design
Improved simulation tools: BDSIM and RFtrack

Key conclusions:

- Can in principle reach or exceed performance target
- Much improved longitudinal, may be useful for collider ring
- Study of collective effects important

Previous design (MAP)

Goal

Achieved

better

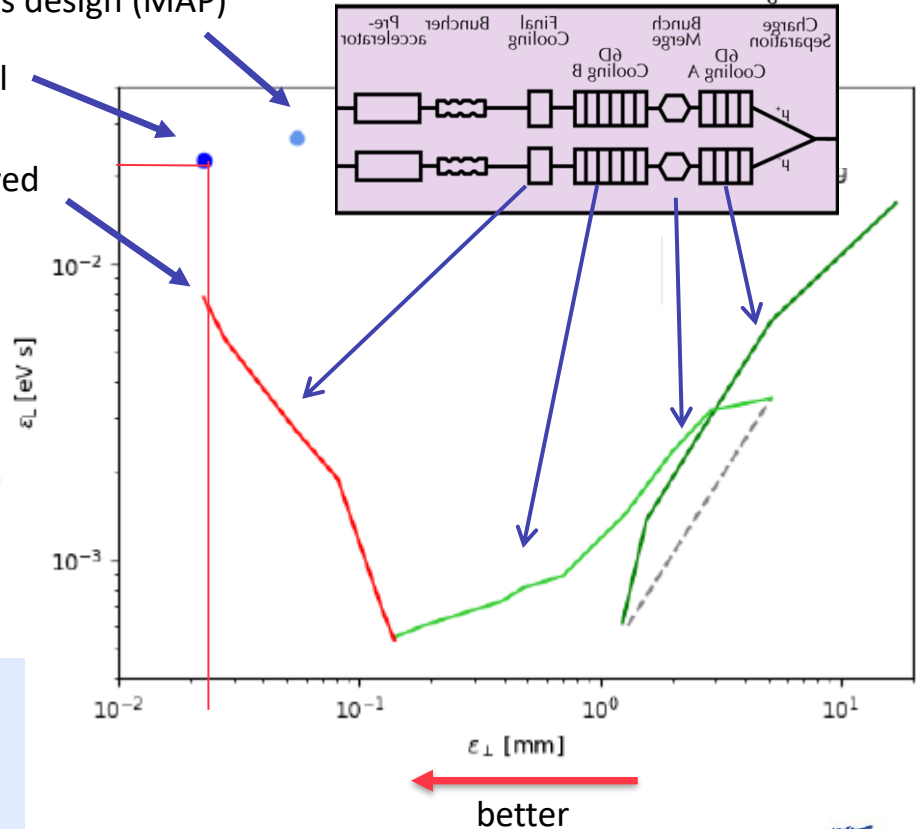

Muon Cooling Technology

Challenges:

- NC RF cavities in magnetic field (30 MV/m)
- HTS magnets (up to 40 T in final cooling)
- Bright beam hard on absorbers and windows
 - Can evaporise liquid hydrogen

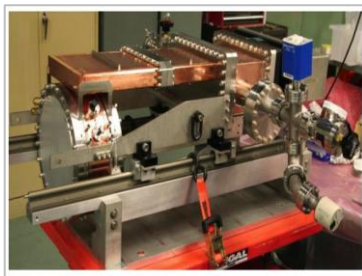

MuCool demonstrated >50 MV/m in 5 T H₂-filled copper Be end caps

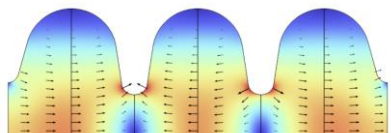
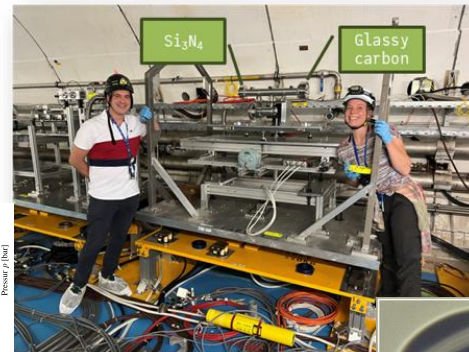

- MAP proved gradient
- Initial RF designs
- More RF design ongoing

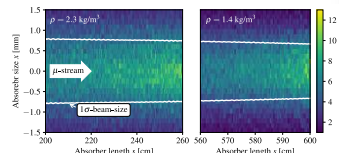

Dipole RF cavities Coils

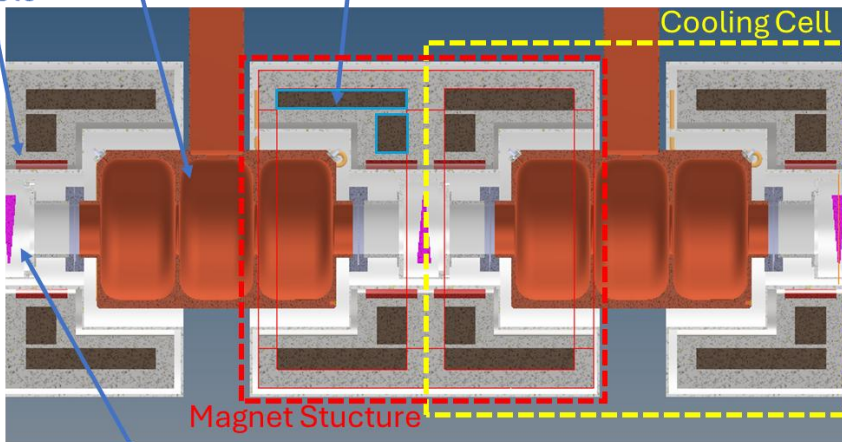

Absorber

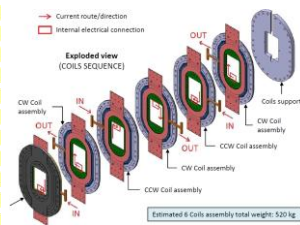

- First window tests performed with protons
- Use of H₂ gas where required

Key conclusions:

- Ready to **ramp-up effort**, in particular prototyping and experimental work, also beam dynamics

RCS Designs

Challenge:

- Uses fast-pulsed normal magnets
- 5 Hz pulses of O(1-10ms)
- 6-35 km circumference
- Cost
- Recover energy from magnetic field
- High bunch charge
- Maintain beam quality

Achieved:

- Lattices for all site independent RCSs
- Beam propagation through complex
- Conceptual design of magnets and power converters
- Optimised design together with RF

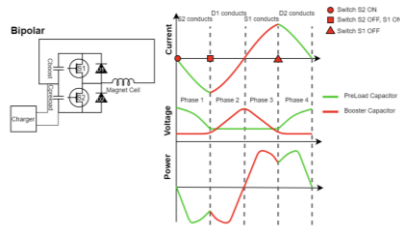
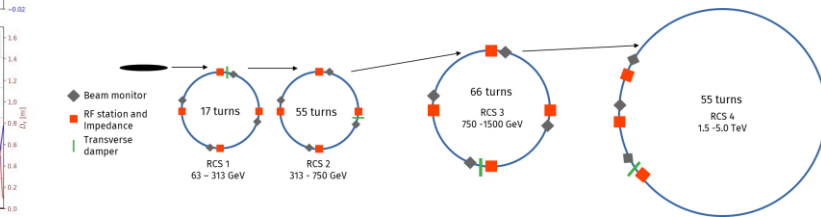
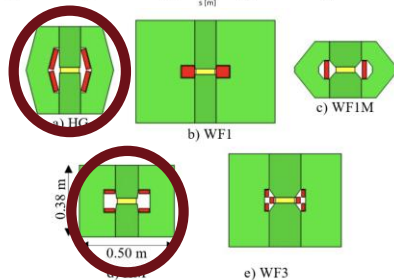
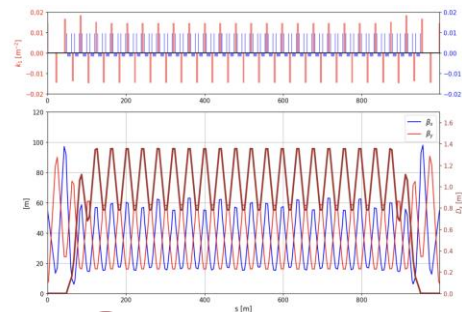

Acceleration

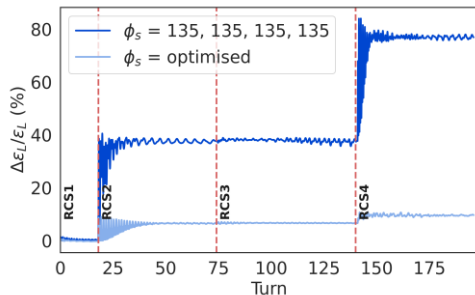
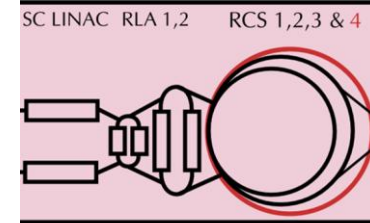

RCS	E [J/m]	Loss [%]	P [MW]
SPS 1	5447	1.1	1.9
LHC 1	5678	1.6	12.8
LHC 2	5752	6.3/2	26.6

Key conclusions:

- 1.3 GHz TESLA-type cavities work
- Emittance transport is OK
- Cost and power is OK
- Need to connect to initial linacs

Collider Ring

Challenges:

500 W/m loss, magnet strength, lattice design with beta 1.5-5 mm, 0.1% beam energy spread

Achieved:

- Magnet shielding design
- Magnet conceptual designs
- Cryogenics concept
- Lattice reaches target beta-functions but not yet full target energy acceptance
- First studies of mover system impact on beam

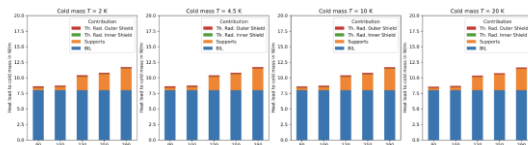
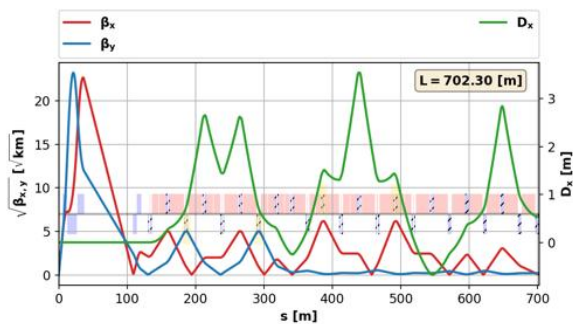

Fig. 6.7.2: Estimated heat load deposited on the cold mass in W/m, as a function of absorber temperature

Cryogenic loads at different temperatures

Shielding (30-40 mm)

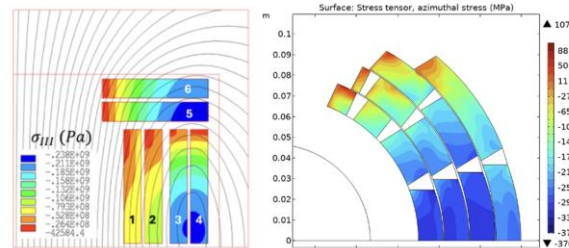
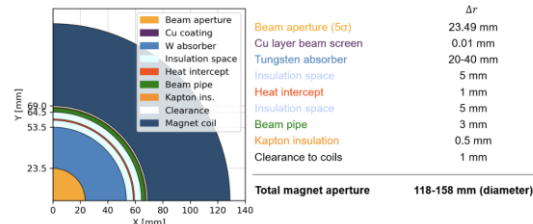
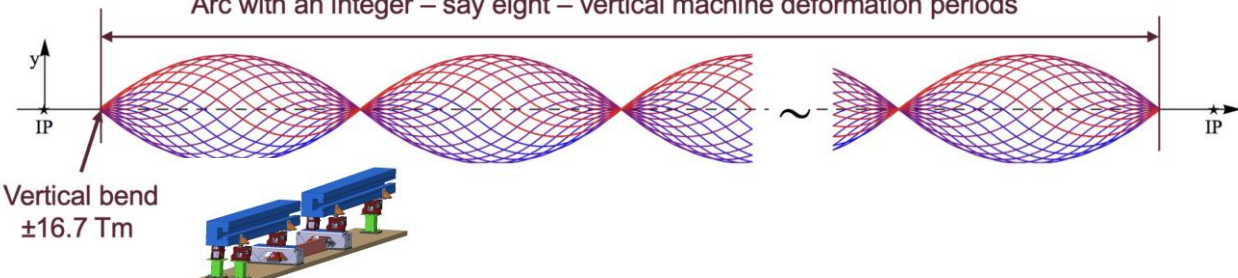

Fig. 6.1.31: Mechanical stress on conductor under Lorentz Forces at nominal current for both block coil and cos-theta magnet configurations.

Arc with an integer – say eight – vertical machine deformation periods



Key conclusions:

- Should improve energy acceptance should somewhat
- OK with energy spread predicted in muon cooling
- Mover system does not compromise beam in regular arcs

Placement

Challenge:
Obtain negligible neutrino flux
Similar impact as LHC

Achieved:

- Detailed modelling
- First good orientation found
- Mover system concept

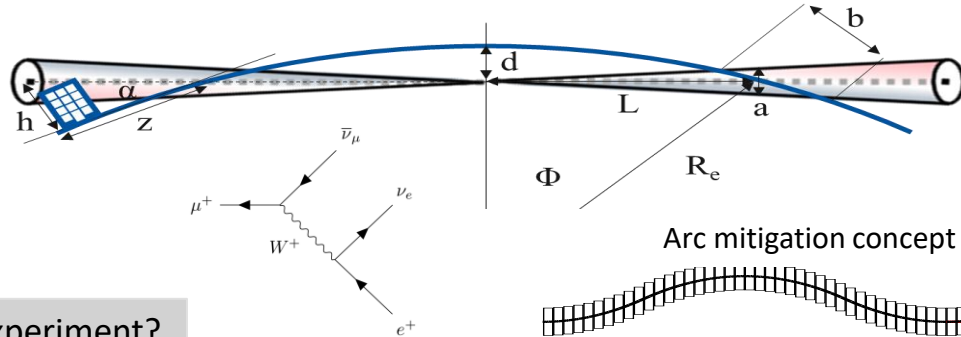

Fermilab site study

Arc mitigation concept

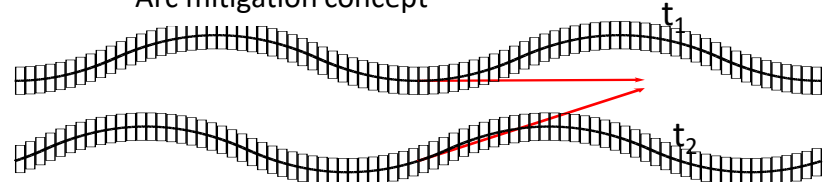

FLUKA and RP studies

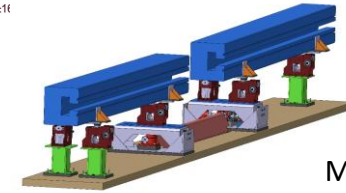
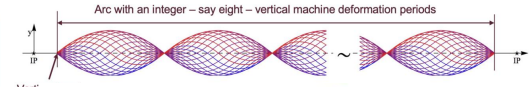
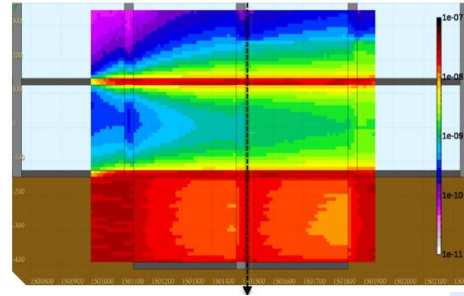

Mover system design

Experiment?

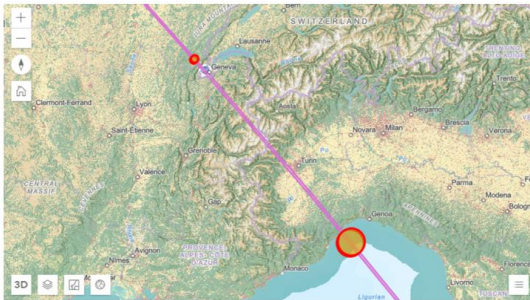
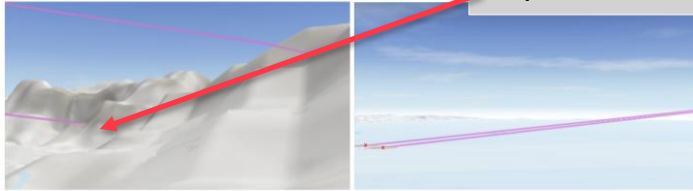

Site study at CERN for experimental insertion

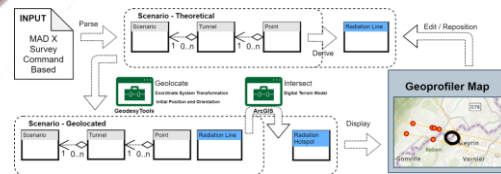

Key conclusions:

- Close to a solution
- Arcs impact similar to current CERN impact
- Hottest spot inside fence is like sitting in a plane
- More work to be done

Summary of Cost Scale and Power Estimate



Bottom up cost estimate

- Component level
- Conceptual designs
- Detailed scaling from other projects

Good agreement with cost scaling by US Snowmass process

Main cost drivers: RF and magnets

Main power driver: RCSs

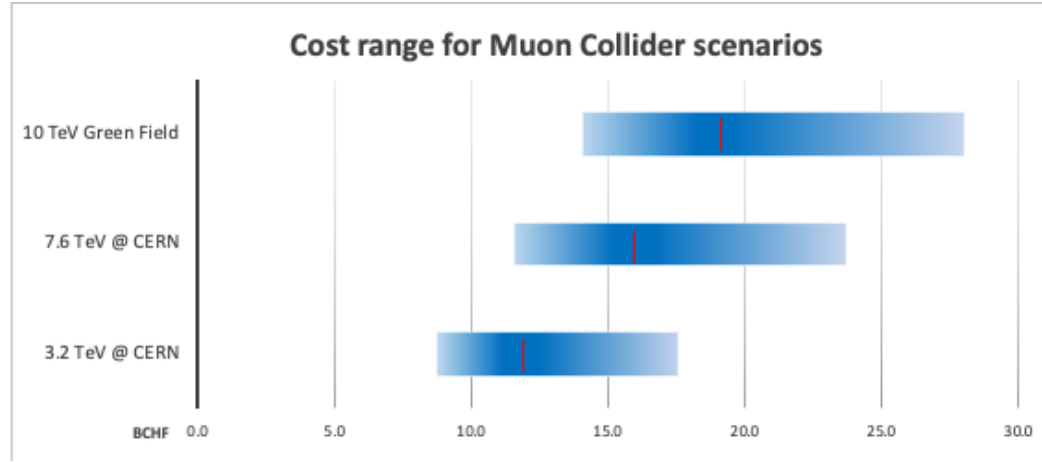

Project Cost (no esc., no cont.)	4	7	12	18	30	50
MC-3						
MC-10						

Summary TABLE full power

	3.2 TeV	7.6 TeV	10 TeV
	MW	MW	MW
P driver	16.700	16.700	16.700
6D Cooling	11.765	11.765	11.765
RLA2	10.770	10.770	10.770
RCS	44.190	108.930	124.680
Collider	10.000	4.100	4.100
General CV	20.000	20.000	20.000
TOTAL	113.425	172.265	188.015

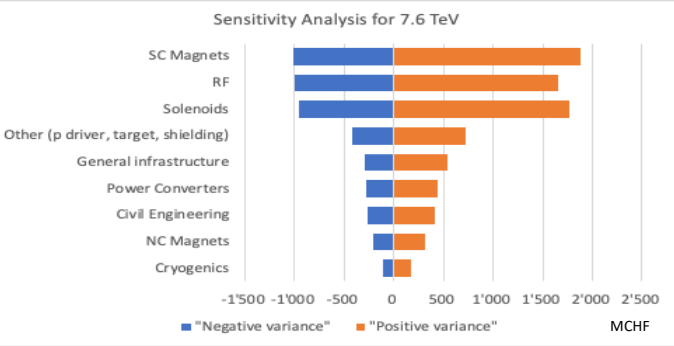
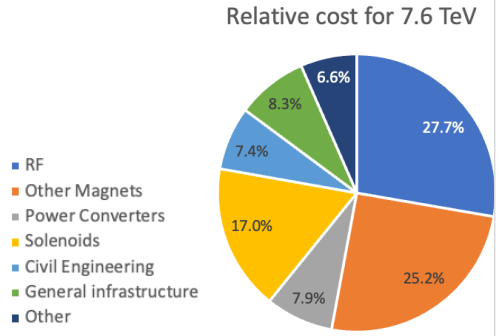

R&D Programme



Accelerator design

- Complete **start-to-end design** to validate and optimize performance, cost, power and risk

Muon cooling technology

- Implementation in steps important for timeline
- **Need hardware**, in particular RF test stands
- **New detector technologies** useful for instrumentation
- Cooling RF requires **urgent test infrastructure**

Detector

- Strong potential for further **improve physics potential** with **technologies, AI and ML**

Magnet programme

- Have conceptual designs, need hardware
- HTS solenoids have important **synergy with society** (e.g. fusion, power generators for windmills, ...)
 - **Industry** is ready to invest
 - Must not miss the **opportunity**

Year	I	II	III	IV	V	VI	VII	VIII	IX	X
Accelerator Design and Technologies										
Material (MCHF)	1.6	3.2	4.8	6.4	9.6	10.8	12.0	12.0	12.0	12.0
FTE	47.1	60.6	75.0	85.0	100.0	120.0	150.0	174.6	177.2	185.1
Demonstrator										
Material (MCHF)	0.6	2.2	3.9	5.4	7.8	15.1	25.9	32.4	31.8	12.6
FTE	9.5	11.0	12.5	29.2	29.7	30.5	25.5	27.7	26.7	25.5
Detector										
Material (MCHF)	0.5	1.1	1.6	2.1	2.1	2.1	2.1	2.6	3.1	3.1
FTE	23.4	46.5	70.0	93.0	93.0	93.0	93.0	116.4	139.5	139.5
Magnets										
Material (MCHF)	3.0	4.9	10.1	10.0	11.0	13.4	11.7	7.2	6.6	4.7
FTE	23.3	28.4	36.4	40.9	44.3	47.1	46.2	37.7	36.1	29.4
TOTALS										
Material (MCHF)	5.7	11.4	20.3	23.9	30.6	41.4	51.7	54.2	53.5	32.4
FTE	103.3	146.5	194.0	248.1	267.0	290.6	314.8	356.3	379.4	379.6

Ideal for **early career experts** since innovation is essential

Muon Cooling Demonstrator

Challenge:

Demonstrate muon cooling technology in stages
Critical for timeline

Achieved:

- Defined the scope and concept, made initial cost estimate, investigated three promising locations at CERN
- Staged timeline to implement demonstrator
- SLAC is moving forward building a 3/1.3 GHz test stand



RF Test stands, to develop novel RF and magnet technologies



One-cell module to test RF in operational magnetic environment



Five-cell module to demonstrate integration of absorber, RF and magnets

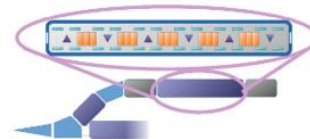

Demonstration of cooling module to show operation with beam



Demonstration of cooling to demonstrate beam physics performance



Muon Cooling Demonstrator

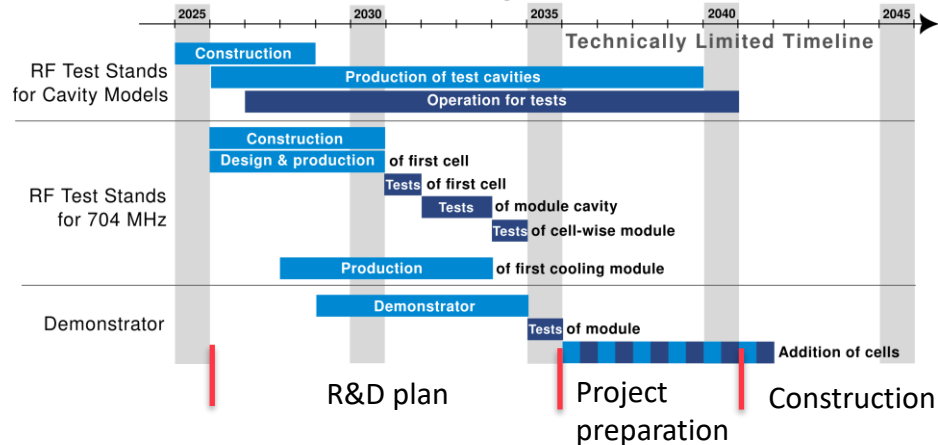

Key conclusions:

- Installation of demonstrator at CERN appears possible with limited cost ($O(10\text{kW})$) proton beam
- Expensive solution with $O(80\text{ kW})$ would allow future upgrade
- Fermilab has approved a study
- RF test stands are critical and urgent
- Consistent with implementation timeline

R&D Plan – Towards Resource Loading



R&D plan widely recognized as a good planning base

R&D task force is establishing an overview of available resources, potential resources, interested partners

- Focus on next five years
- Priorities being defined to maximize the impacts of the resources available
- Contact Federico Meloni, Emilio Nanni, or me

National Academies Recommendation 1: The United States should host the world’s highest-energy elementary particle collider around the middle of the century. This requires the immediate creation of a national muon collider research and development program to enable the construction of a demonstrator of the key new technologies and their integration.

<p>High-energy acceleration CEA, CERN, BNL, STFC(?)</p>	<p>Demonstrator CERN, INFN, FNAL, SLAC, STFC</p>
<p>RCS powering CERN, U. Bologna, KIT, Tu-Chemnitz Infineon Bipolar (DE), Hitachi semiconductors (CH)</p>	<p>Magnets CERN, INFN, U. Bologna, Poli Torino, U. Twente, EPFL/SPC, KEK, U. Southampton, TU Tampere, PSI, CEA, TU Darmstadt Tape manufacturers, ASG, ICAS, ENI, Gauss Fusion, EUROFusion</p>
<p>MDI CERN, INFN, U. Padova, FNAL, other US?</p>	
<p>RF CERN, LBNL, IIT, NIU, INFN, SLAC, CEA, Daresbury/ULAN, U. Strathclyde, U. Helsinki, U. Tartu, U. Rostock THALES</p>	<p>Legend Academic partners/interest Industrial partners/interest</p>



National Lab Accelerator Study Group for a Muon Collider

Study Group Membership composed of representatives of DOE National Labs with Accelerator Facilities

Argonne: Philippe Piot,
Berkeley: Jean-Luc Vay
Brookhaven: Steve Peggs,
FNAL: Steve Gourlay (Chair),
JLab: Robert Rimmer,
Los Alamos: Steve Russel,
Oak Ridge: Fulvia Pilat,
SLAC: Emilio Nanni
Scientific Secretary: Diktys Stratakis, USMCC

Summary of Charge

- Identify the key accelerator challenges to enable the realization of a 10 TeV Muon Collider
- Assess the capabilities and roles of U.S. national laboratories in contributing to these critical areas
- Build on existing U.S. and IMCC R&D planning documents to identify areas of alignment, overlap, and gaps
- Weekly community seminars through March
- Report this summer

Synergy Examples

HTS solenoids have strong synergy with fusion reactors

- Can potentially contribute to huge impact on climate change

HTS is also useful for wind power generators, motors, material science, health applications

Efficient power converter for different applications

- Interest of collaboration by Infineon, ...

...

Collaboration on target solenoid/fusion with Fusion for Energy, ERUOFusion, GaussFusion, ENI is key example

- Have agreements that can lead to resources
- An opportunity for particle physics to make an important impact on society

<https://indico.cern.ch/event/1439855/contributions/6461515/>

Design of 10 MW HTS wind generator

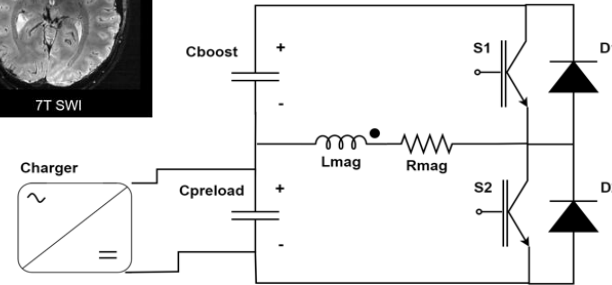
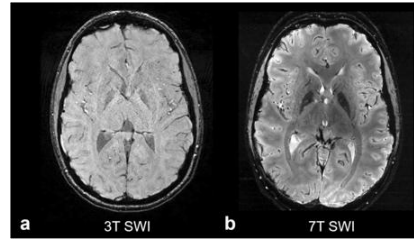
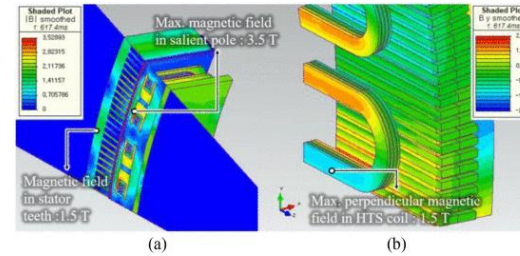

Early career experts are very motivated by the required and possible innovations
Excellent training ground



Conclusion



Excellent technical progress has been made, in spite of resource limitations

- Supported by review committees from LDG, MuCol, and IAC reviews

Have global R&D programme proposal that needs to be funded

- Strong interest in different regions hopefully translates into resources

A muon collider is disruptive

- US Particle Physics Projects Prioritization Panel (P5) called it
 - “This is our muon shot”
- It will push beyond the current boundaries
- It will be the first of its kind
- High-risk, high-benefit

Important innovation is required

- Not all issues have been solved
- This means uncertainty and risk
- But also the potential to be creative and invent

Strong synergy with societal applications

<https://www.facebook.com/cern/videos/the-future-of-particle-physics-david-gross-cern70/509915295164473/>

Many thanks to the collaborators for all the work

Our web page:

<http://muoncollider.web.cern.ch>

If you want to join:

muon.collider.secretariat@cern.ch

To the younger: You will have to make it work

Reserve



Key Parameters

Param.	Unit	Site independent		CERN 2 tunnels		CERN 1 tunnel	
Sqrt(s)	TeV	3	10	3.2	7.6	3.2	7.6
L/IP	$10^{34} \text{ cm}^{-2}\text{s}^{-1}$	1.8	17.5	2	10	0.9	7.9
Int L	ab^{-1}	1	10	1	10	1	10
Accumulation time	years	2+2.8	2+2.9	2+2.5	2+5	2+5.6	2+6.3
C	km	4.5	11.4	4.8	8.7	11	11
B_{dipole}	T	11	14	11	14	4.8	11
Collider dipole technology		Nb3Sn	HTS	Nb3Sn	HTS	NbTi	Nb3Sn or HTS

Accumulation time: Time to obtain the integrated luminosity with two IPs.

Ramp-up over the first three years 5%, 25%, 70% of nominal.

R&D Plan Deliverables and Resources



Technologies	Deliverables	Key parameters and goals
Magnets		
Target solenoid	Develop conductor, winding and magnet technology	1 m inner / 2.3 m outer diameters, 1.4 m length, 20 T at 20 K
Split 6D cooling solenoid	Demonstration of solenoid with cell integration	510 mm bore, gap 200 mm, 7 T at 20 K
Final cooling solenoid	Build and test HTS prototype	50 mm bore, 15 cm length, 40 T at 4 K

Technologies	Deliverables	Key parameters and goals
Magnets		
Target solenoid	Develop conductor, winding and magnet technology	1 m inner / 2.3 m outer diameters, 1.4 m length, 20 T at 20 K
Split 6D cooling solenoid	Demonstration of solenoid with cell integration	510 mm bore, gap 200 mm, 7 T at 20 K
Final cooling solenoid	Build and test HTS prototype	50 mm bore, 15 cm length, 40 T at 4 K
Radiofrequency		
muon cooling RF cavities	Design, build and test RF cavities	352 MHz and 704 MHz in 10 T field
Klystron prototype	Design/build with Industry 704 MHz (and later 352 MHz) klystron	20 MW peak power, 704 MHz / 352 MHz
RF test stands	Assess cavity breakdown rate in magnetic field	20-32 MV/m, 704 MHz-3 GHz cavities in 7-10 T
SCRF cavities	Design SRF cavities, FPC and HOM couplers, fast tuners, cryomodules	352 MHz, 1056 MHz, 1.3 GHz, 1 MW peak power (FPC)
Muon Cooling		
5-cell module	Build and test first 5-cell cooling module	Infrastructure to test cooling modules with muon beam
Cooling demonstrator	Design and build cooling demonstrator facility	3 x 10 ¹³ muons, 22.5 μm emittance, 40 T field
Final cooling absorber	Experimental determination of final cooling absorber limit	
Design & Other Technologies		
Neutrino flux mover system	Prototype components and tests as needed	Range to reach O(±1mradian)
Beam Instrumentation	Instrumentation component designs	Prototype components and tests as needed
Target Studies	Target design and test of relevant components	0.4 MJ/pulse, 5 Hz
Start-to-End Facility Design	A start-to-end model of the machine consistent with realistic performance specifications	Lattice designs of all beamlines, simulation codes with relevant beam physics, tuning and feedback procedures

Totals:
 Duration 10 years
 Accelerator: 300 MCHF material, 1800 FTEy
 Detector: 20 MCHF material, 900 FTEy

Year	I	II	III	IV	V	VI	VII	VIII	IX	X
Accelerator Design and Technology										
Material (MCHF)	1.6	3.2								
FTE	47.1	60.6								
Demonstrator										
Material (MCHF)	0.6	2.2								
FTE	9.5	11.0								
Detector										
Material (MCHF)	0.5	1.1	1.6	2.1	2.1	2.1	2.1	2.6	3.1	3.1
FTE	23.4	46.5	70.0	93.0	93.0	93.0	93.0	116.4	139.5	139.5
Magnets										
Material (MCHF)	3.0	4.9	10.1	10.0	11.0	13.4	11.7	7.2	6.6	4.7
FTE	23.3	28.4	36.4	40.9	44.3	47.1	46.2	37.7	36.1	29.4
TOTALS										
Material (MCHF)	5.7	11.4	20.3	23.9	30.6	41.4	51.7	54.2	53.5	32.4
FTE	103.3	146.5	194.0	248.1	267.0	290.6	314.8	356.3	379.4	379.6

Timeline and R&D Programme Proposal

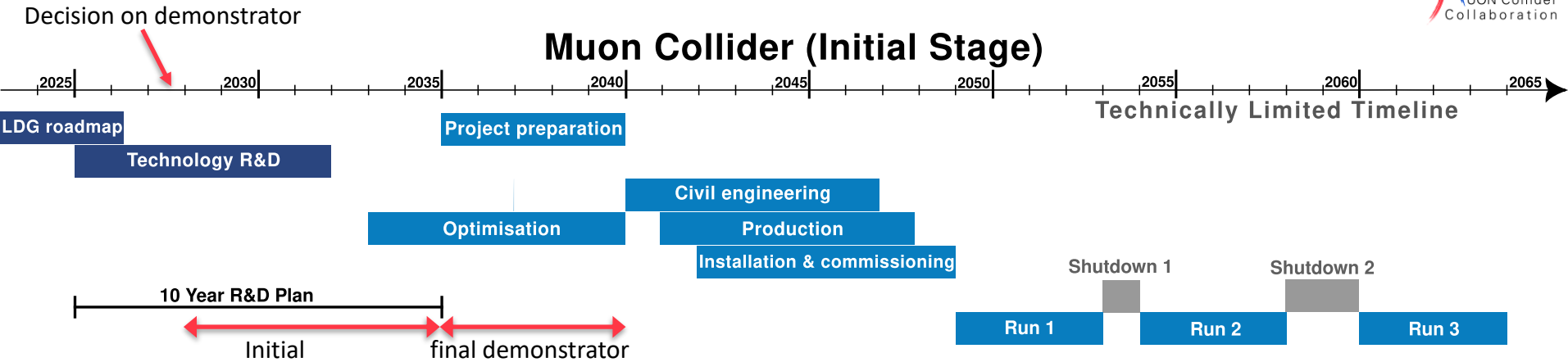

Timeline is driven by R&D

Most ambitious example to define R&D programme priorities

- Muon collider next flagship after HL-LHC











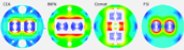







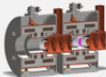

Other options

- In Europe after a higgs factory
- In the US to become leader at the energy frontier

R&D timeline drivers

- Superconducting magnets
 - Collider ring with no HTS dipoles for first stage
- Muon cooling demonstration
 - RF cavities, solenoids, absorbers, integration, demonstration with beam

Magnet R&D Impact

	HEP and NP 	High-field science 	NMR 	MRI	Fusion 	Motors/generators 
TM1 20@20 		High field, low consumption			High-field, large bore and large stored energy	
TM2 SOLID 		High field, low consumption		High-field large bore, cryo-free technology		
TM3 UHF-DEMO 	FCC-ee, CLIC (e+ source)	Ultra-high-field	Ultra-high-field			High-field, compact windings
TM4 RCS-String		High pulsed power and energy recovery			High pulsed power and energy recovery	
TM5 MBHY	FCC-hh, SppC					
TM6 MBHTS 	FCC-hh, SppC					3D, compact pole winding
TM7 MBHTSY 	FCC-hh, SppC					3D, compact pole winding
TM8 MQHTSY	FCC-hh, SppC					3D, compact pole winding

L. Bottura

Practical Examples



- **Fusion for Energy** (ITER EU Domestic Agency)

- Framework agreement and first addendum in final negotiation
- Contribution to the design of the HTS target solenoid, relevant to the central solenoid of DTT



- **EUROFusion** (next step European fusion reactor)

- Framework agreement signed in 2023, first addendum signed in 2024
- Contribution to the design of the HTS target solenoid, relevant to the magnets of a Volumetric Neutron Source proposed as next step in the European fusion strategy



- **Gauss Fusion** (one of the leading EU fusion start-ups)

- Consultancy agreement signed in 2023
- CERN contribution to the design of the LTS/HTS GIGA stellarator magnets, based on advances in the HTS target solenoid



- **ENI** (oil and gas energy giant)

- Framework agreement and first addendum signed in 2024
- Collaboration on the conceptual design and project proposal for the CERN construction of a large bore HTS solenoid (20@20 model coil) relevant to the muon collider and fusion



- IFAST-2 proposal to **INFRA-2025-TECH-01-02** (CERN, INFINEON, PSI)

- Proposal of fast pulsed power cell + magnet system sent to IFAST-2 coordination for ranking at TIARA
- Industrial interest in rapidly pulsed and large energy/power supplies

European Accelerator R&D Roadmap



Reviews in Europe and the US found muon collider promising

- Requires important innovation

European Strategy for Particle Physics Update (**ESPPU**) supported muon collider R&D in 2020

CERN Council charged Laboratory Directors Group (**LDG**) to develop Accelerator R&D Roadmap

- Directors of institutes, e.g. INFN Frascati, PSI, DESY, RAL, CERN, ...

LDG formed five panels, one on Muon Collider

Muon Collider panel developed an **R&D Roadmap** with the help of the global community until end of 2021

Label	Begin	End	Description	Aspirational		Minimal	
				[FTEy]	[kCHF]	[FTEy]	[kCHF]
MC.SITE	2021	2025	Site and layout	15.5	300	13.5	300
MC.NF	2022	2026	Neutrino flux mitigation system	22.5	250	0	0
MC.MDI	2021	2025	Machine-detector interface	15	0	15	0
MC.ACC.CR	2022	2025	Collider ring	10	0	10	0
MC.ACC.HE	2022	2025	High-energy complex	11	0	7.5	0
MC.ACC.MC	2021	2025	Muon cooling systems	47	0	22	0
MC.ACC.P	2022	2026	Proton complex	26	0	3.5	0
MC.ACC.COLL	2022	2025	Collective effects across complex	18.2	0	18.2	0
MC.ACC.ALT	2022	2025	High-energy alternatives	11.7	0	0	0
MC.HFM.HE	2022	2025	High-field magnets	6.5	0	6.5	0
MC.HFM.SOL	2022	2026	High-field solenoids	76	2700	29	0
MC.FR	2021	2026	Fast-ramping magnet system	27.5	1020	22.5	520
MC.RF.HE	2021	2026	High Energy complex RF	10.6	0	7.6	0
MC.RF.MC	2022	2026	Muon cooling RF	13.6	0	7	0
MC.RF.TS	2024	2026	RF test stand + test cavities	10	3300	0	0
MC.MOD	2022	2026	Muon cooling test module	17.7	400	4.9	100
MC.DEM	2022	2026	Cooling demonstrator design	34.1	1250	3.8	250
MC.TAR	2022	2026	Target system	60	1405	9	25
MC.INT	2022	2026	Coordination and integration	13	1250	13	1250
			Sum	445.9	11875	193	2445

Table 5.5: The resource requirements for the two scenarios. The personnel estimate is given in full-time equivalent years and the material estimate in million Swiss francs. The number of PhD students is given in the last column. Similar costs. Colours are in <http://arxiv.org/abs/2201.07895> and

Muon Collider Roadmap CT



Short, intense proton bunch

Protons produce pions which decay into muons which are captured

Ionisation cooling of muon in matter

Acceleration to collision energy

Collision

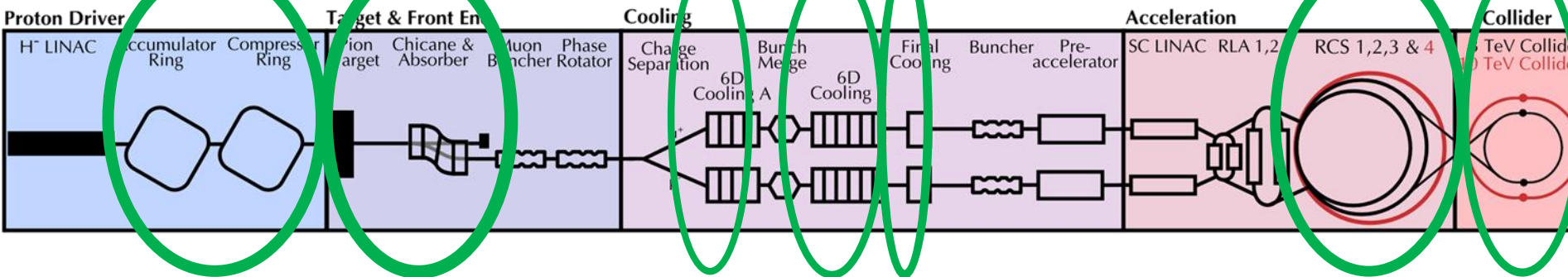

- Proton driver
- bunch compression

- Graphite target
- Target solenoid

- Muon cooling design
- 6D cooling solenoids
- 6D cooling RF cavities
- Final cooling solenoids

- Pulsed magnets and power converters
- RCS RF system

- Collider ring dipoles
- Final focus quadrupoles
- Machine-detector interface

Identified and prioritized with community
Other areas need now also to be addressed
(some work started)

MuCol Timeline



LDG anticipated input to next ESPPU by 2026
The ESPPU has been advanced to early 2025

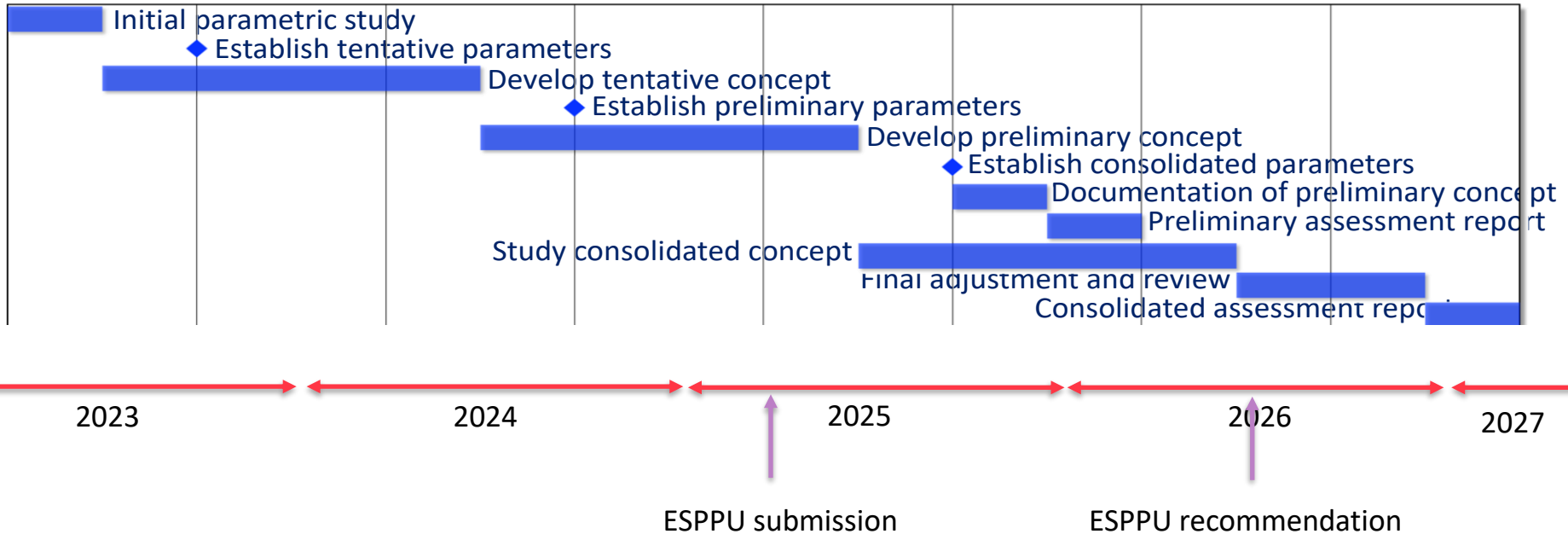

Muon Cooling Challenges

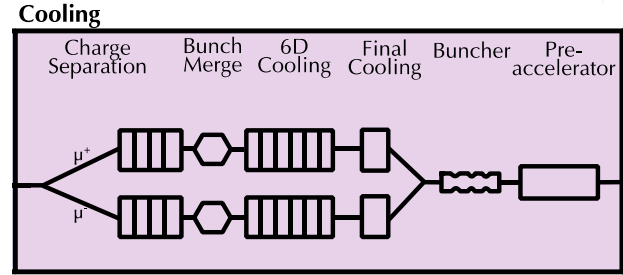
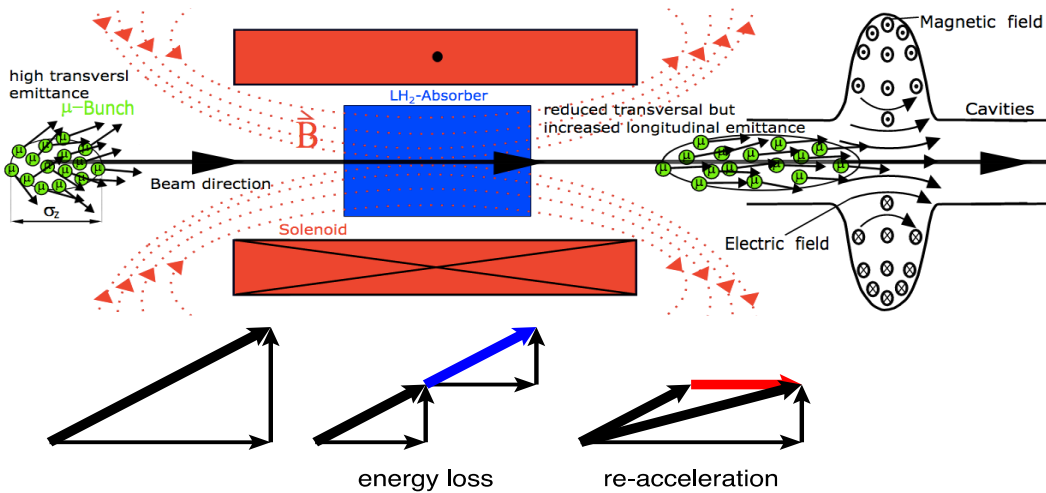

High field solenoids minimise beta-function and impact of multiple scattering

Energy loss = cooling

Multiple scattering = heating

$$\frac{d\epsilon_{\perp}}{ds} = - \frac{1}{(v/c)^2} \frac{dE}{ds} \frac{\epsilon_{\perp}}{E} + \frac{1}{2} \frac{1}{(v/c)^3} \left(\frac{14 \text{ MeV}}{E} \right)^2 \frac{\beta\gamma}{L_R}$$

ESPPU Submission March 2025



Collaboration produced ESPPU input:

- Short, **ten-page** report (10p)
- **Addendum** to answers specific questions from ESPPU (18p)
- **Back-up document** (406p, 450 signatories)
 - **Assessment** of collider status based on progress of R&D
 - **R&D Plan**
 - Final polishing is ongoing, you Urgently sign up to support

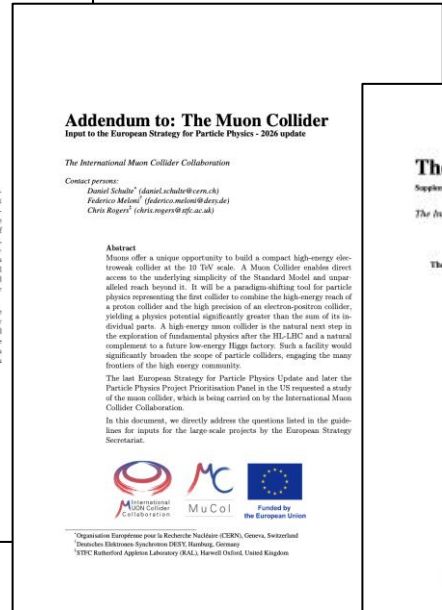
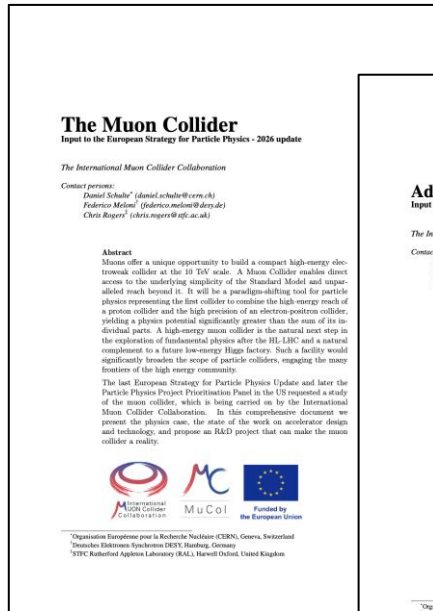

Muon Cooling Technology

Challenges:

- NC RF cavities in magnetic field (30 MV/m)
- HTS magnets (up to 40 T in final cooling)
- Bright beam hard on absorbers and windows
 - Can evaporise liquid hydrogen

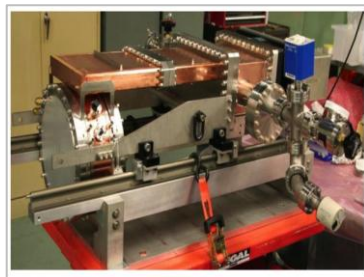

MuCool demonstrated >50 MV/m in 5 T H₂-filled copper Be end caps

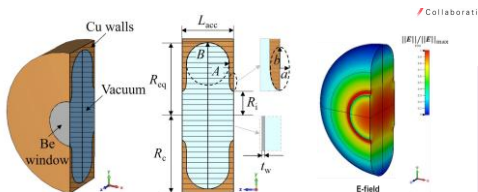

- MAP proved gradient
- Initial RF designs
- More RF design ongoing

Fig. 6.3.1: Design of the 704 MHz cavity for muon cooling.

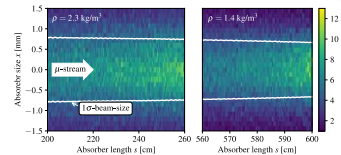
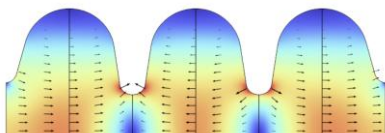
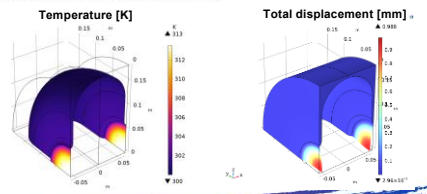

- First window tests performed with protons
- Use of H₂ gas where required

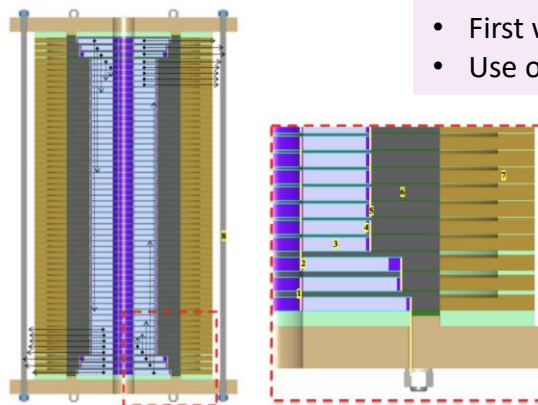

Fig. 6.1.7: Cross-section of the 40 T solenoid; the arrows indicate the axial and radial Lorentz forces acting on each pancake. The lengths of the radial arrows have been scaled down by a factor of 3.

- 40 T final cooling solenoid conceptual designs exist
- 55 T might be possible

Key conclusions:

- Ready to **ramp-up effort**, in particular prototyping and experimental work, also beam dynamics

Muon 6D Cooling Cell



- Challenge:**
- Integrated 6D cooling cell
 - HTS solenoid designs
- Achieved:**
- Cooling cell engineering design almost ready
 - Solenoid models for use in beam dynamics optimisation

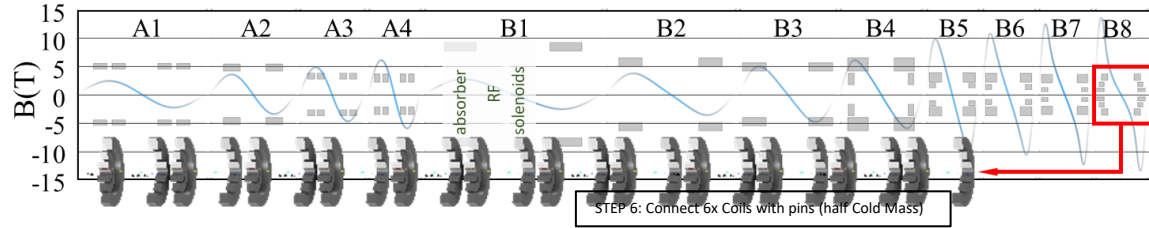

Cooling cells, ≈ 1 km length channel: absorber, RF, solenoid
 About 3000 solenoids, axis field $\approx 2...14$ T
 Free bore diameter from 90 mm to 1.5 m

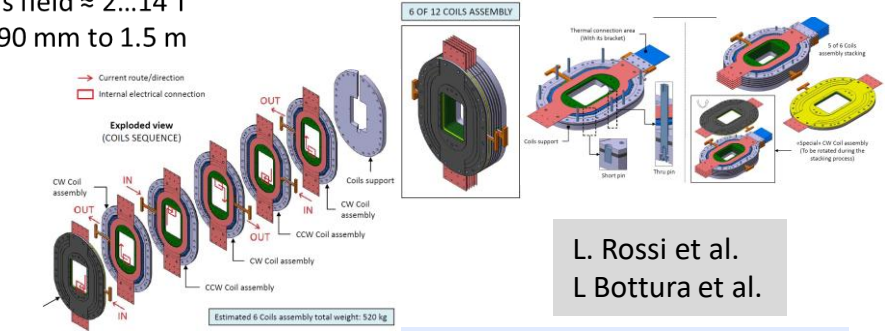
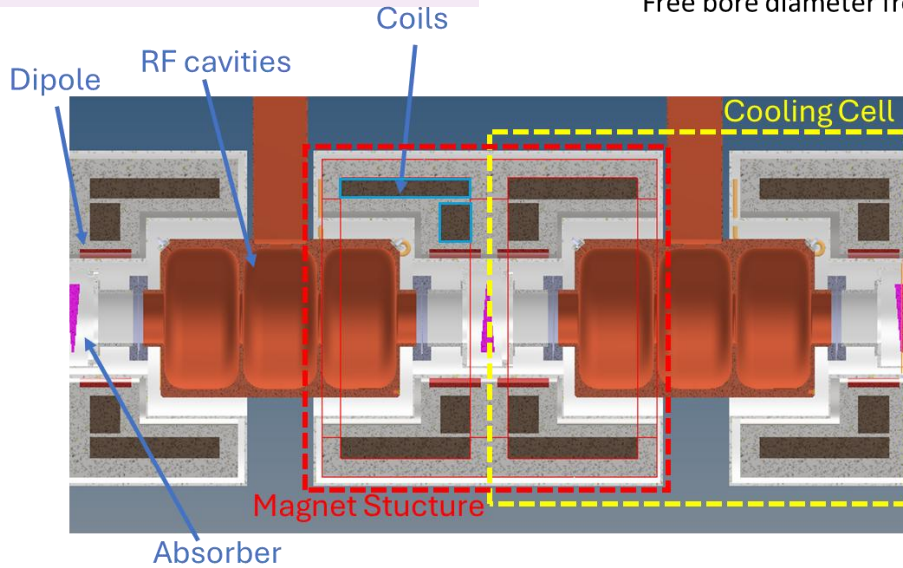

L. Rossi et al.
 L. Bottura et al.

- Key conclusions:**
- Key challenge is force from magnetic field
 - Concept to connect flanges developed
 - Iterations to improve overall and components design also considering beam dynamics is required/ongoing
 - Conceptual design ready in a few months

RCS Designs

Challenge:

- Uses fast-pulsed normal magnets
- 5 Hz pulses of O(1-10ms)
- 6-35 km circumference
- Cost and power efficient acceleration
- High bunch charge
- Maintain beam quality

Achieved:

- Lattices for all site independent RCSs
 - Strong synchrotron motion
 - Including hardware specifications
- Beam propagation through complex works

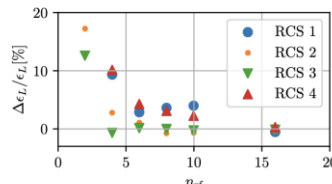
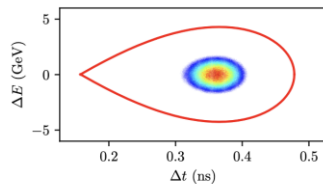

Acceleration

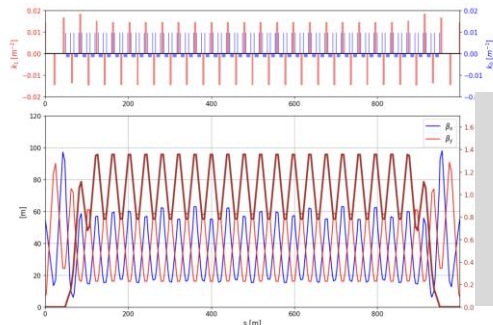
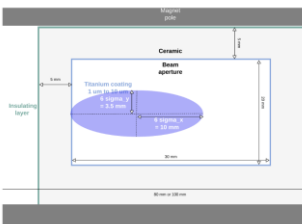
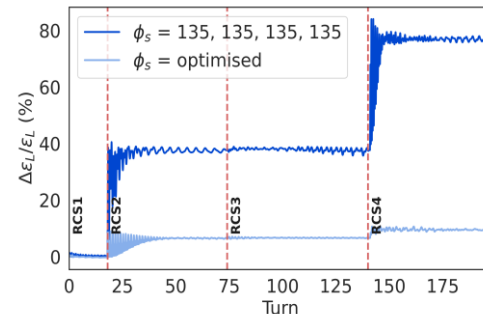
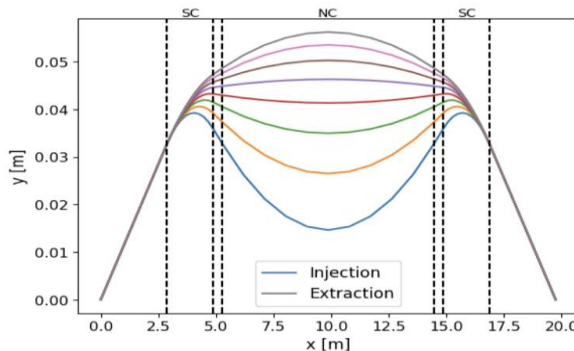
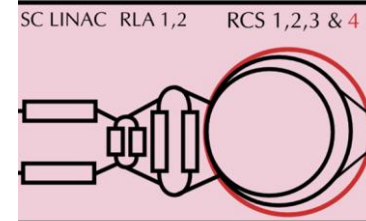

Lattice: A. Chance et al.
 Long. dynamics: H. Damerell et al.
 RF: Alexej Grudiev et al.
 Power converter: F. Boattini et al.
 Magnets: L. Bottura et al.

Key conclusions:

- 1.3 GHz TESLA-type cavities work
- Emittance transport is OK
- Need to connect to initial linacs

Fast-ramping RCD Dipoles

Challenge:

Fast ramping normal magnets (1-10 ms) with efficient energy recovery in power converter (200 MJ stored in magnets)

Achieved:

- Conceptual design of magnets and power converters
- Optimised design together with RF
- Power converters can switch sign of voltage on capacitors

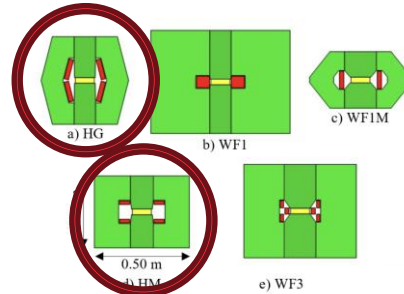
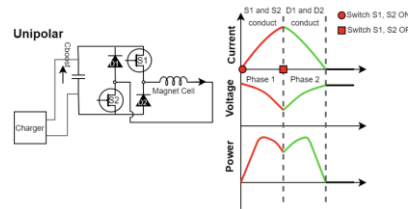
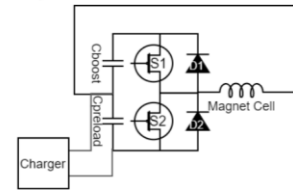

Fig. 6.1.18: Summary of the optimized geometries (the cross sections are to scale): a) Hourglass magnet, b) Window-frame WF#1, $J = 10 \text{ A/mm}^2$, c) Window-frame WF#1M, $J = 20 \text{ A/mm}^2$, d) Window-frame WF#3, $J = 20 \text{ A/mm}^2$.



Bipolar



Power converter: F. Boattini et al.
Magnets: L. Bottura et al.

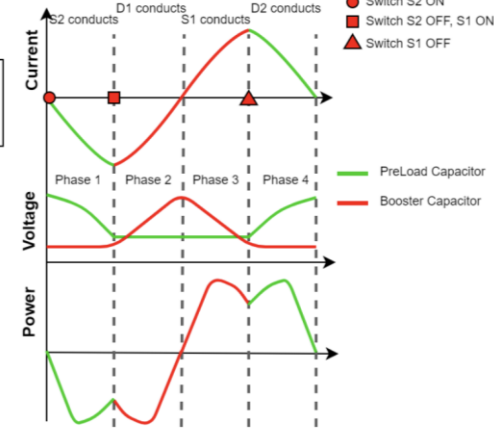
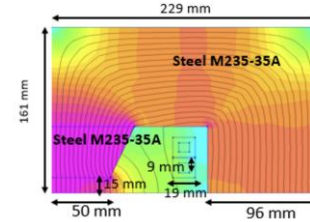

RCS	E [J/m]	E_{iron} [J/m]	E_{copper} [J/m]	Loss [%]	P [MW]
SPS 1	5447	10	52	1.1	1.9
LHC 1	5678	9.2	80.6	1.6	12.8
LHC 2	5752	63.4	298	6.3/2	26.6

Energy in magnets, losses per cycle and total power at 5 Hz including cooling

Key conclusions:

- High recovery efficiency for RCSs (98-99%)
- Ready for experimental optimization/models/prototypes

Collective Effects

Goal:
Identify collective effects intensity bottlenecks

- Achieved:**
- Initial studies for proton complex
 - Assessed impedances (beam screen and RF cavities) in RCSs and collider ring
 - Studying counter-rotating beam impedance
 - Studies started on muon cooling

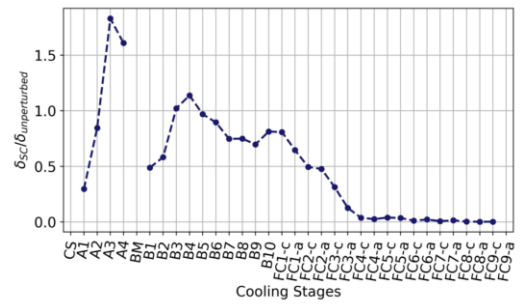
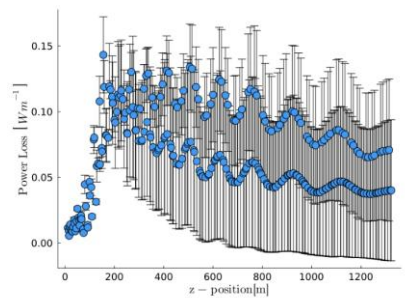
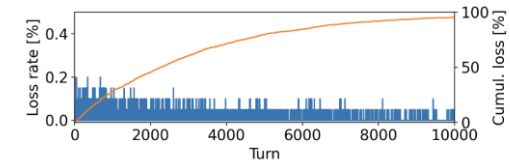
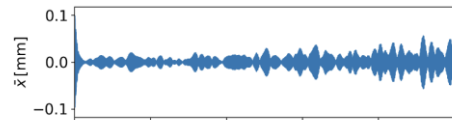
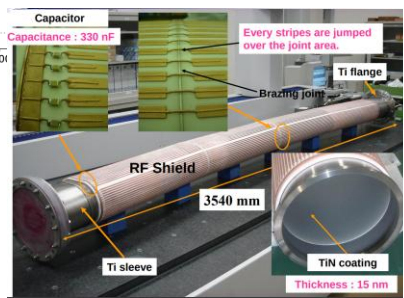
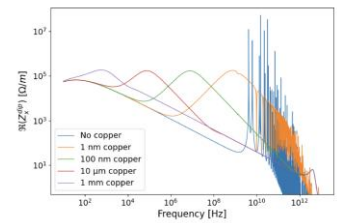
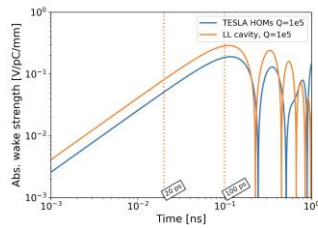
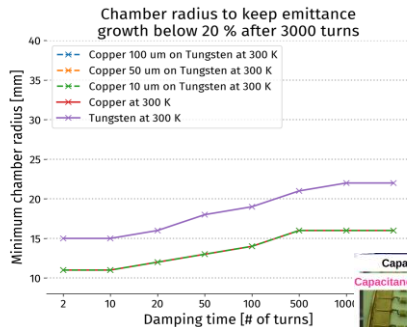

Key conclusions:

- Impedances in RCSs and collider ring can be taken care of by design
- Beam-beam can be handled by 20 turn feedback
- Resistive wall in muon cooling is OK
- Further key detailed studies: beam loading, longitudinal and transverse space charge in 6D cooling, impedance of cooling absorbers

Lattice Designs



International
Muon Collider
Collaboration

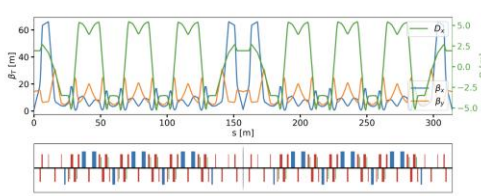
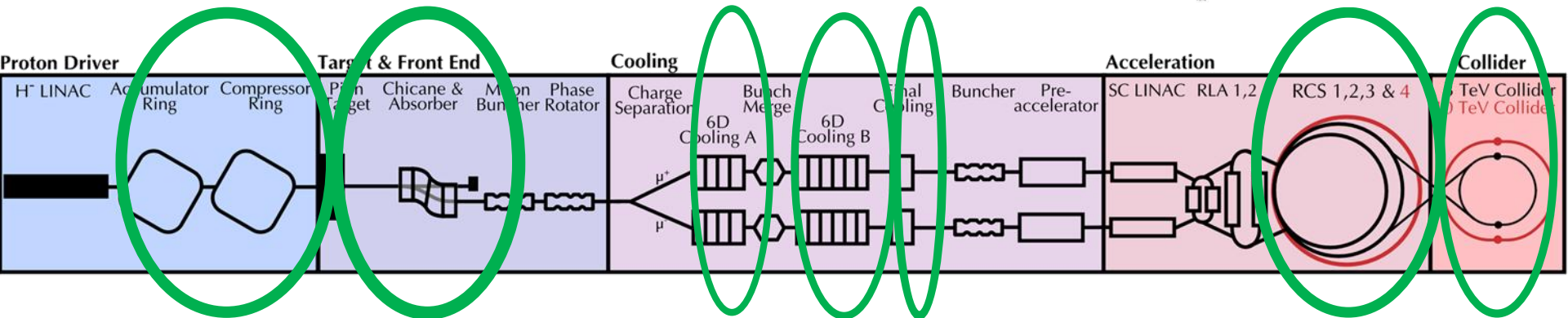
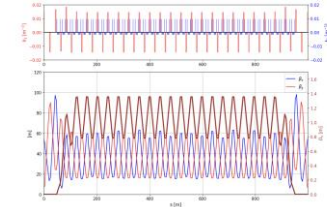
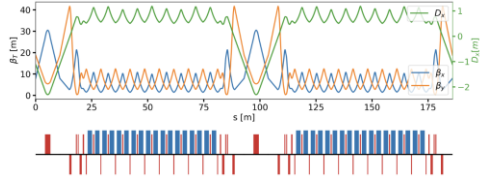

Lattice design is progressing well

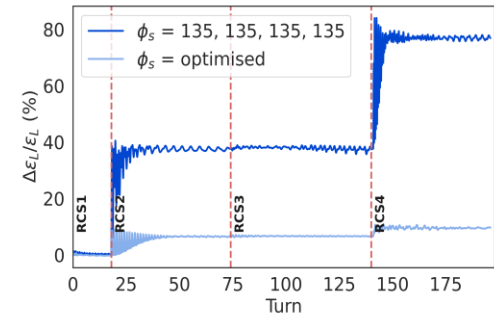

Collider Ring Magnets

Challenge:

High-field collider ring magnets with large aperture

Achieved:

- New method developed to identify field limit, depending on technology, temperature, cost, aperture, considering current, stress and protection (quadrupoles, dipoles, combined function magnets)
- Different conceptual dipole designs (block coil, cos-theta)
- Combined function design ongoing

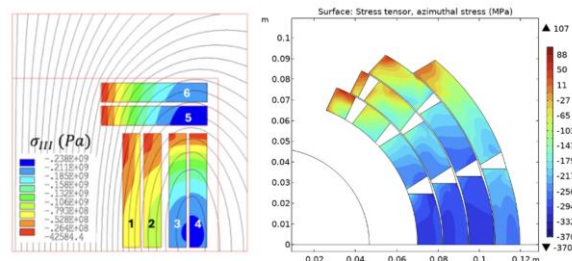

Fig. 6.1.31: Mechanical stress on conductor under Lorentz forces at nominal current for both block coil and cos-theta magnet configurations.

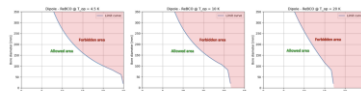
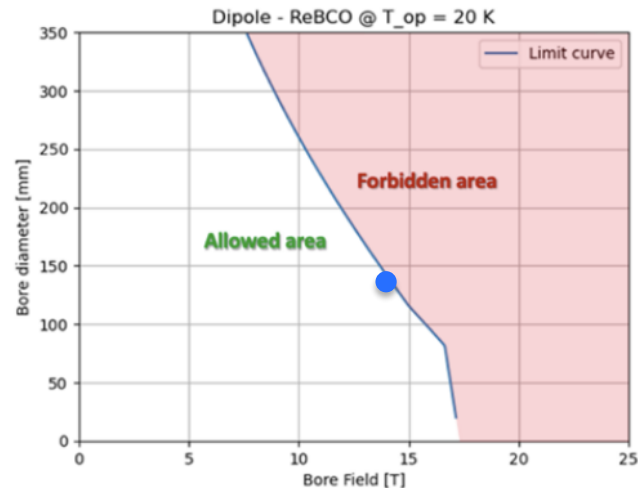
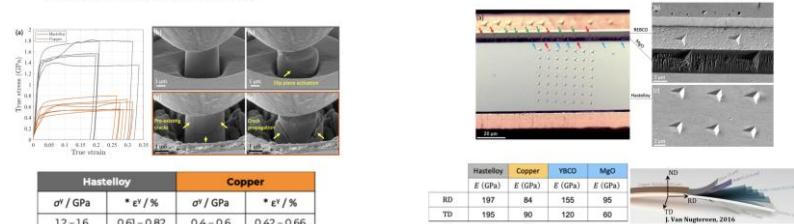

Fig. 6.1.26: A-B plot for dipoles built with REBCO and operated at 4.5 K, 10 K and 20 K.

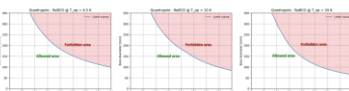

Fig. 6.1.27: A-G plot for quadrupoles built with REBCO and operated at 4.5 K, 10 K and 20 K.

Key conclusions:

- Dipoles appear feasible:
 - NbTi at 4 K, 4.8 T, 16 cm aperture
 - Nb3Sn at 4 K, 11 T, 16 cm aperture
 - HTS at 20 K, 14 T, 14 cm aperture
- Quad in dipole best combined solution
- Experimental programme is now essential