

Development of the liquid hydrogen (LH₂) target for RI beam physics

Hongna Liu
Beijing Normal University





Outline

- ❑ **Why do we develop the LH2 target ?**
- ❑ **General features of the LH2 target we developed**
- ❑ **Status of the STRASSE system for RIBF-RIKEN**
- ❑ **Status of the MULAN target for HIAF**



Radioactive Isotope Physics

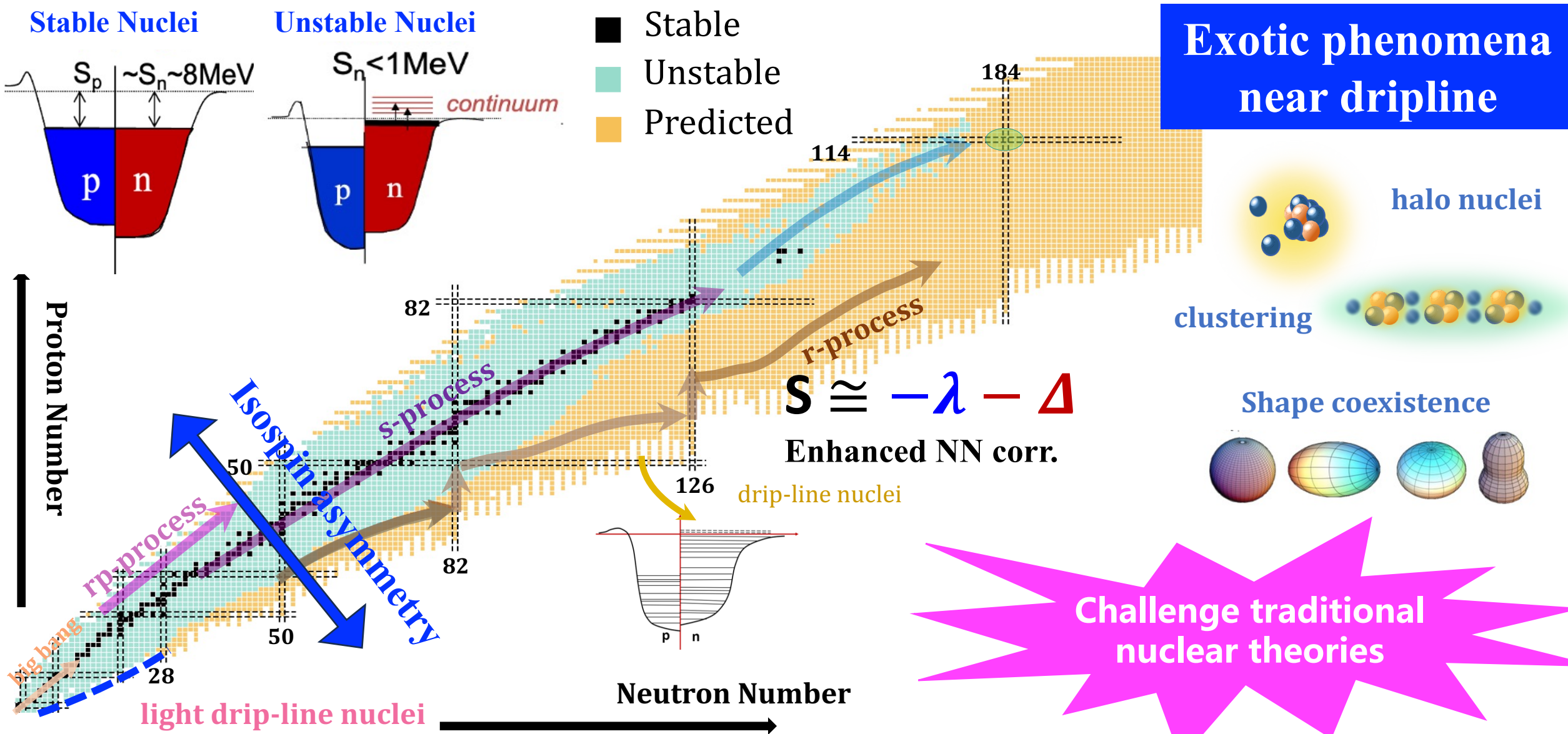

Shell evolution towards the drip line

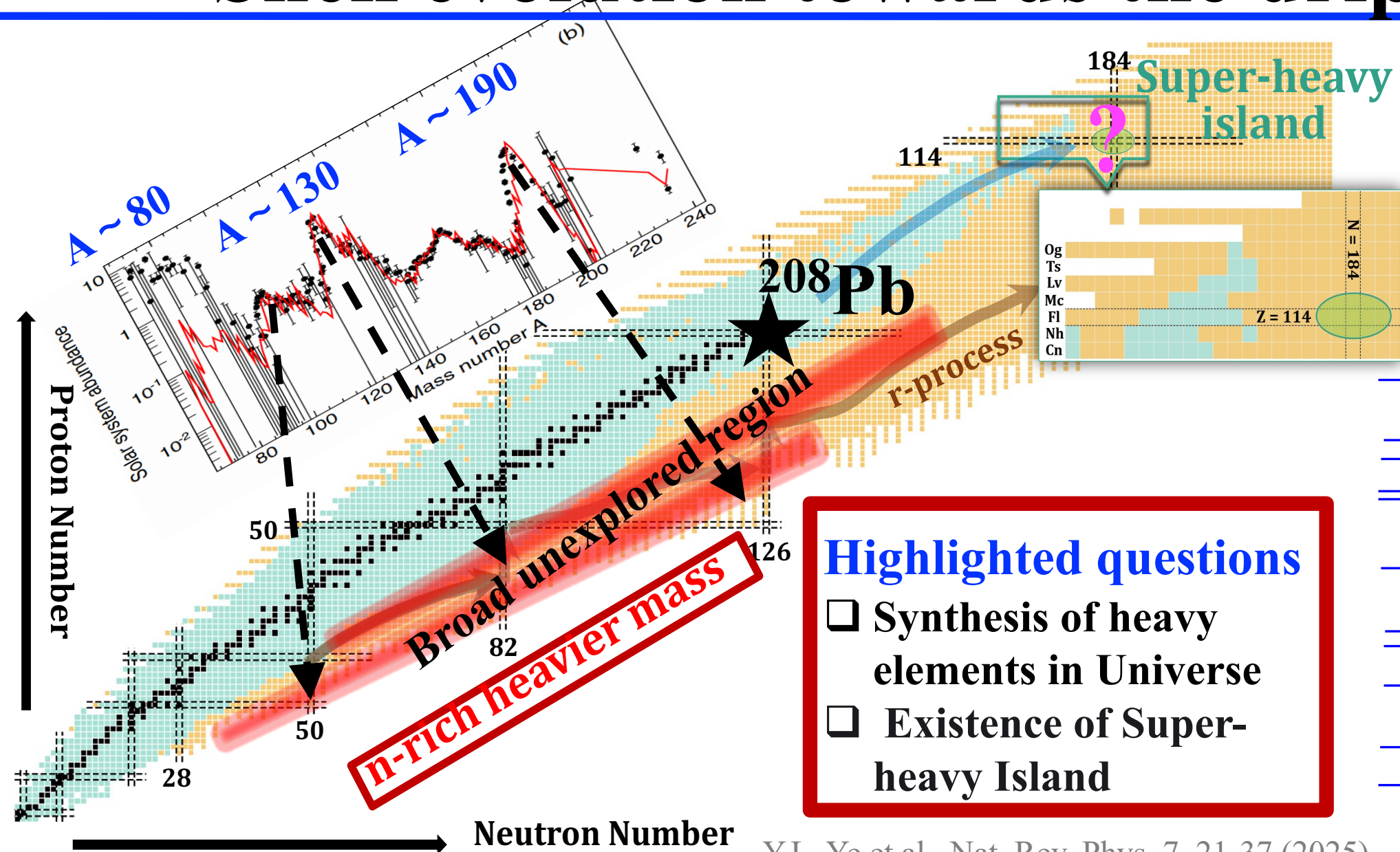

Shells in Atom

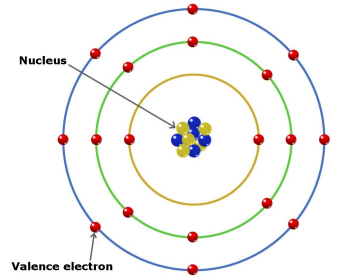

Shell evolution

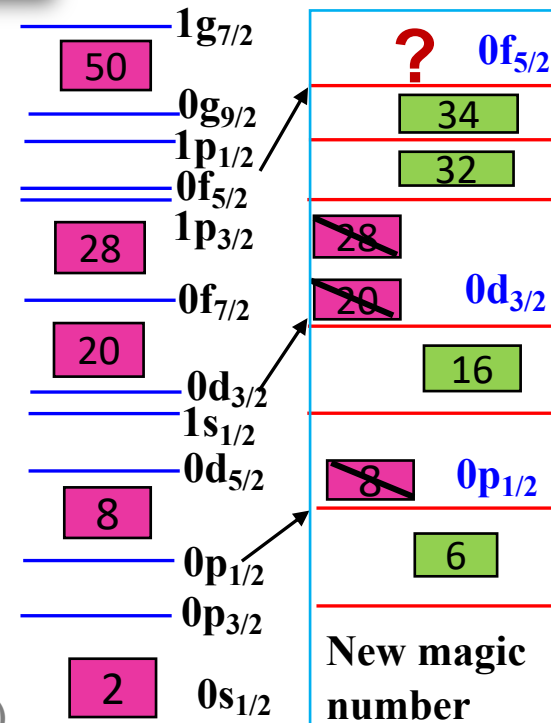

Highlighted questions

- Synthesis of heavy elements in Universe
- Existence of Super-heavy Island

Radioactive Isotope Beam Facilities Worldwide

^{238}U 3.5×10^{11} /s @ 1500 MeV/u

^{238}U 6.24×10^{12} /s
@ 345 MeV/u

^{238}U 5×10^{13} /s
@ 200 MeV/u
(\rightarrow 400 MeV/u)

^{238}U 1×10^{11} /s
@ 840 MeV/u

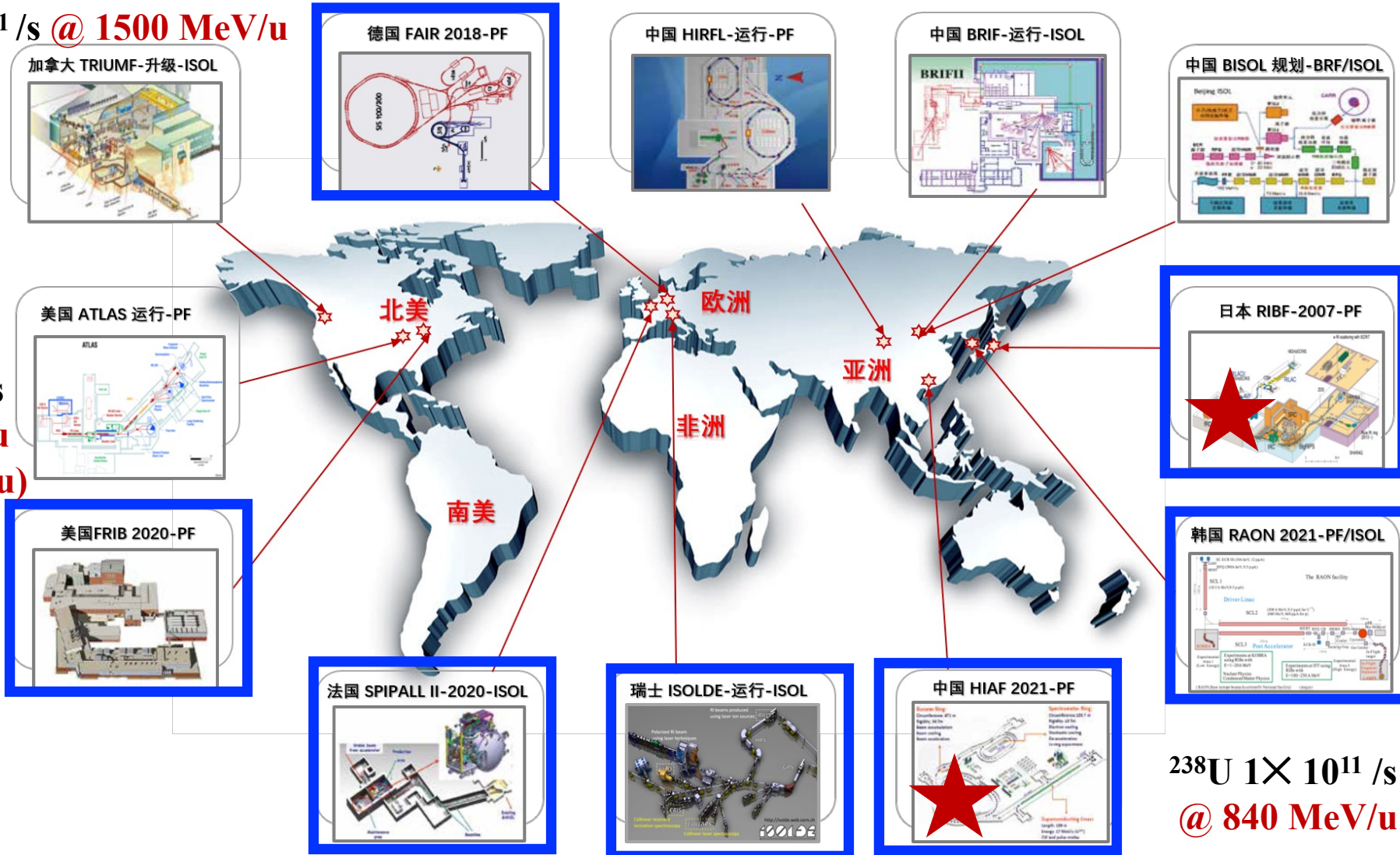

Luminosity = Beam Intensity \times Target Thickness \times Cross section

Accessible range of unstable nuclei



Knockout reactions in inverse kinematics

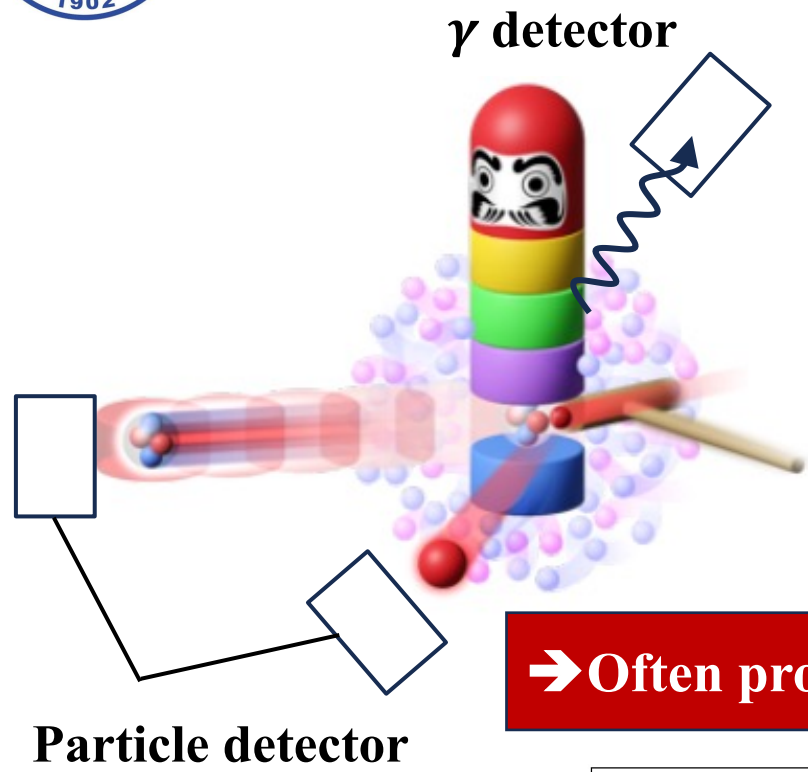

(0.1-few GeV/u)
Knocking out a piece
 (nucleon / cluster)
By a hammer
 (target)
With a large impact
 (large momentum transfer)

Yield Beam-intensity

$$N = \sigma I N_{tgt}$$

tens of mb thick target

→ Often provide 1st experiment observable $E(2_1^+)$ to characterize shell effects

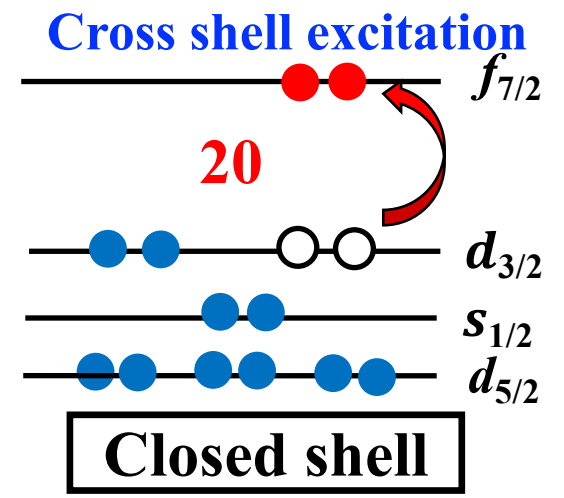
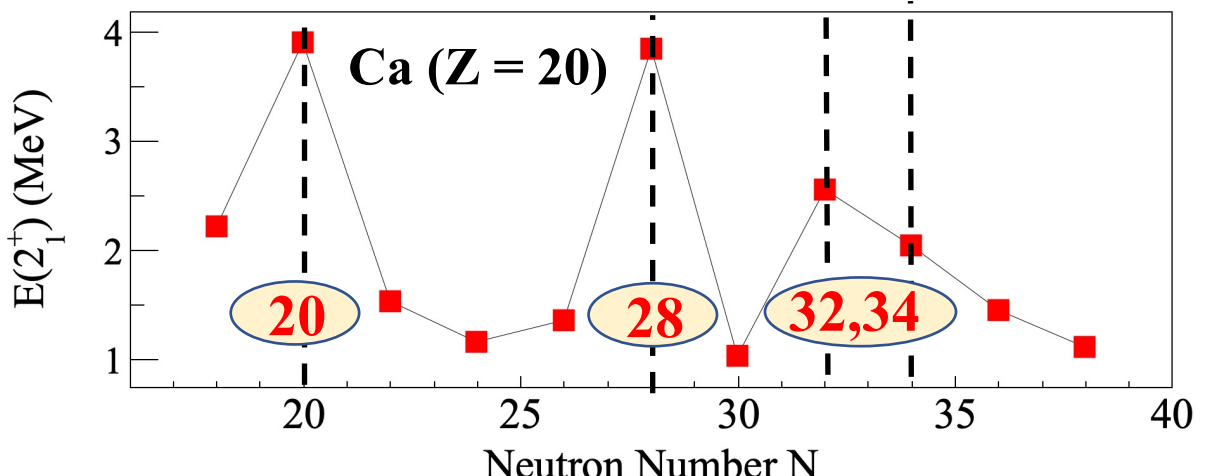

Knockout reactions in inverse kinematics

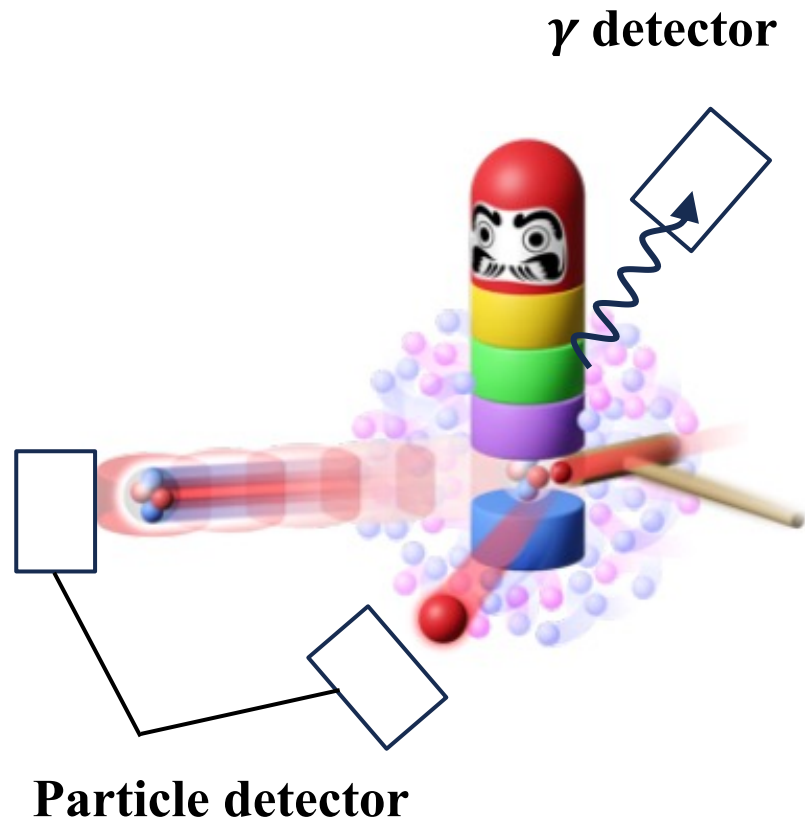

Different hammers

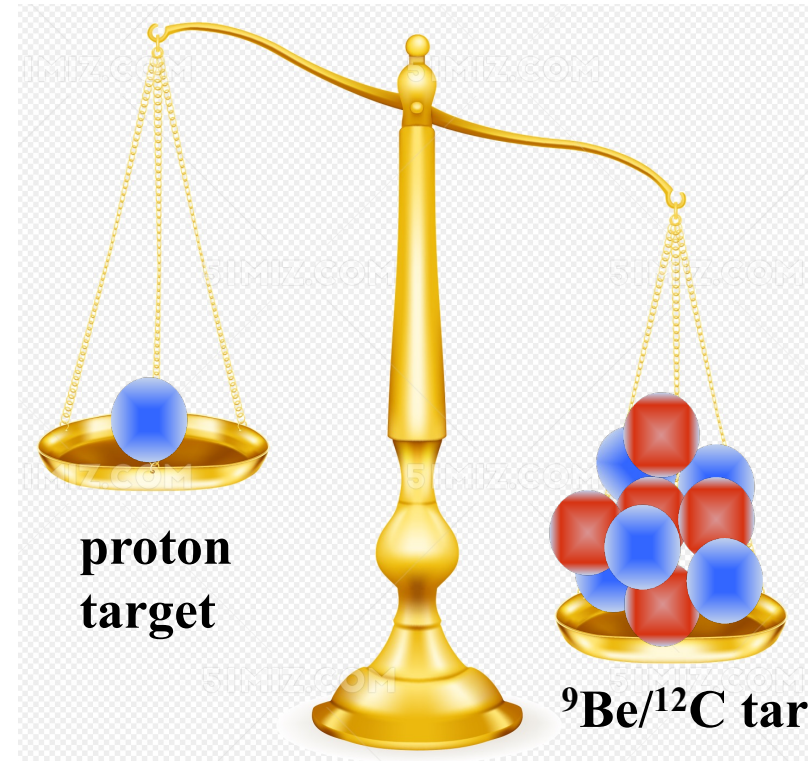
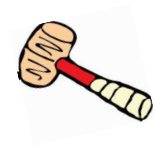

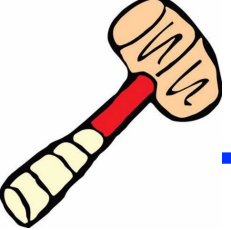

Knockout reaction with the Be/C target

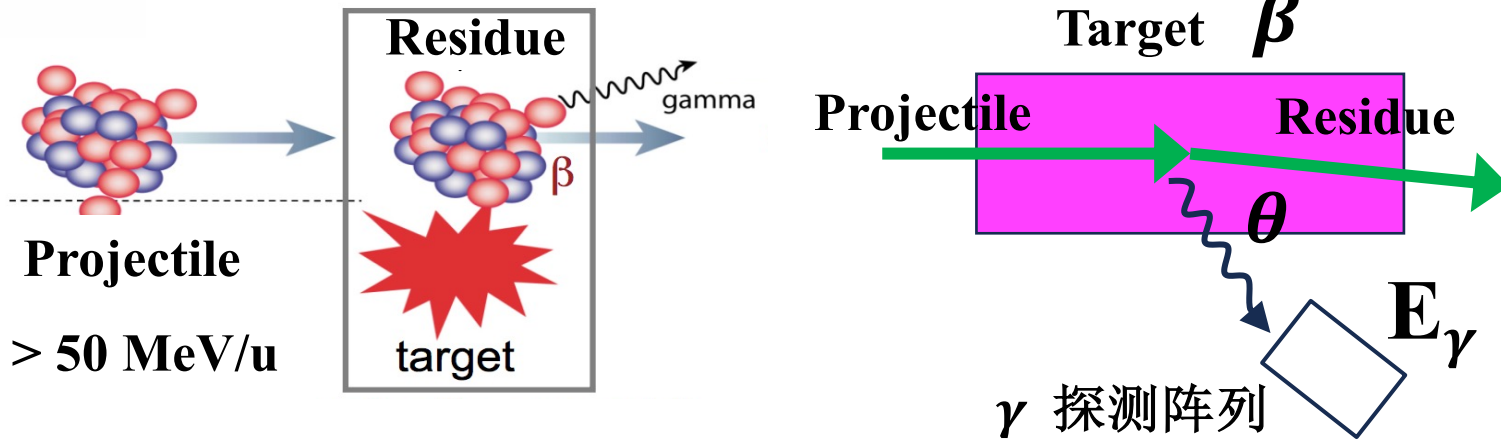

In-beam γ spectroscopy

$$E_0 = \frac{E_\gamma (1 - \beta \cos \theta)}{\sqrt{1 - \beta^2}}$$

Doppler Shift Correction

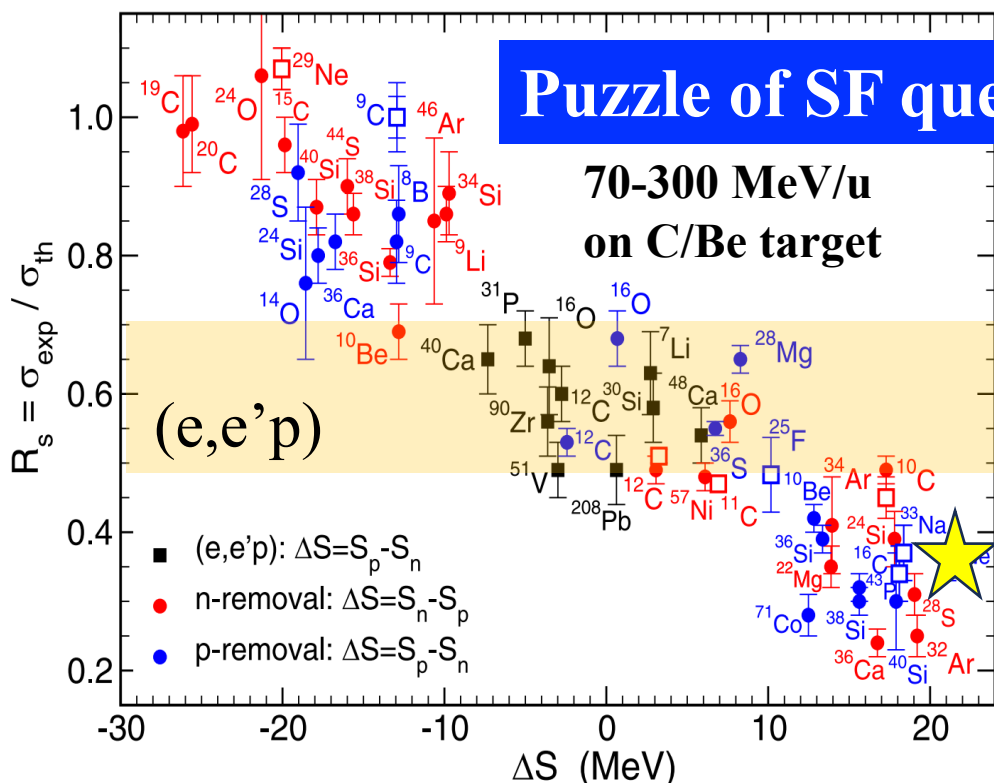

Be/C target



- ❑ Unknow target status after reaction
- ❑ Too thick target spoil γ -ray energy resolution

$$R_s \equiv \frac{\sigma_{\text{exp}}}{\sigma_{\text{th}}}$$

J. A. Tostevin et al., PRC 103, 054612 (2021).

J. Lee et al., PTEP 2016, 083D01(2016).

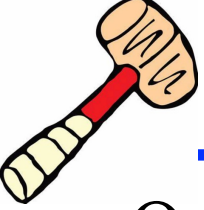

Knockout reactions induced by proton target

Quasi-free scattering (QFS)

Energy & Momentum conservation

$$\vec{P}_{\text{beam}} + \vec{P}_{\text{target}} = \vec{P}_{\text{frag}} + \vec{P}_1 + \vec{P}_2$$

Angle & Kinematic energy of recoil particles

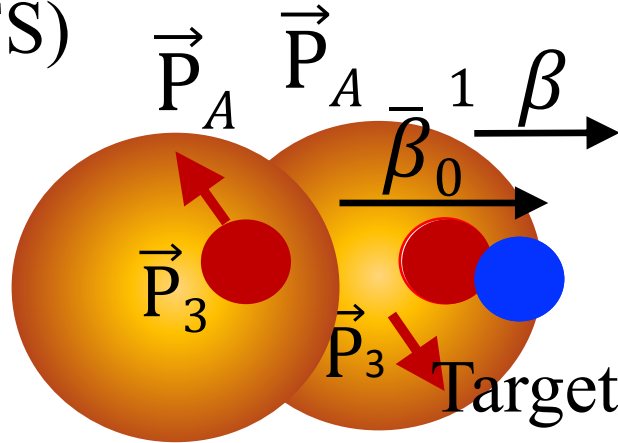

Before the reaction

\vec{P}_1

\vec{P}_2

After the reaction

V. Panni *et al.*, PLB 753, 204 (2016).

L. Atar *et al.*, PRL 120, 052501 (2018)

Allow kinematics complete measurement

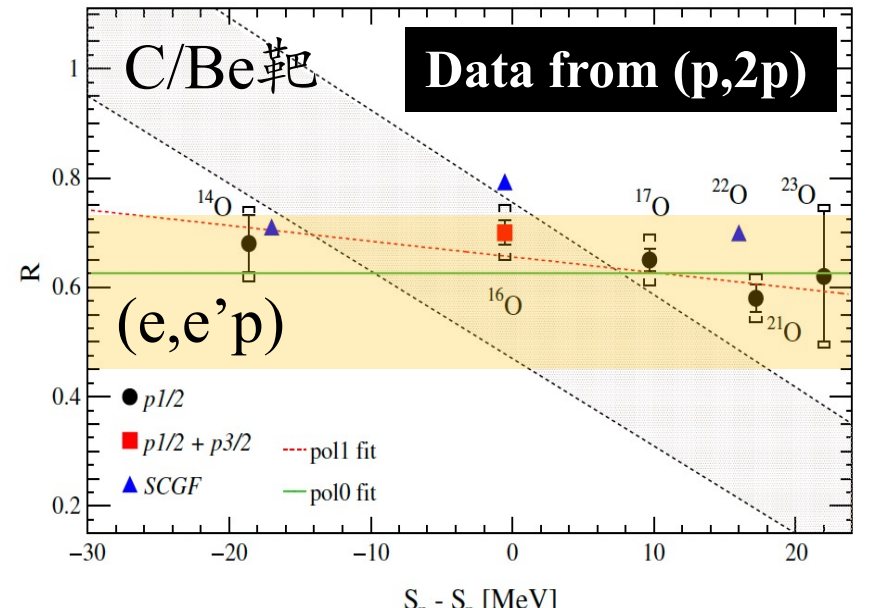
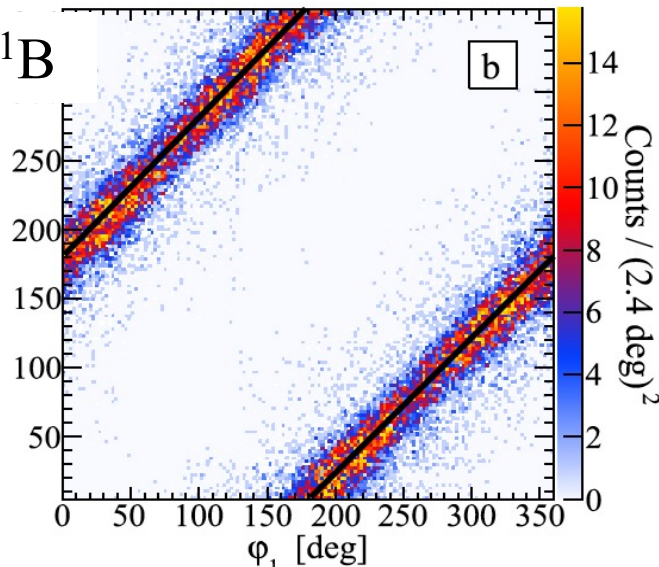
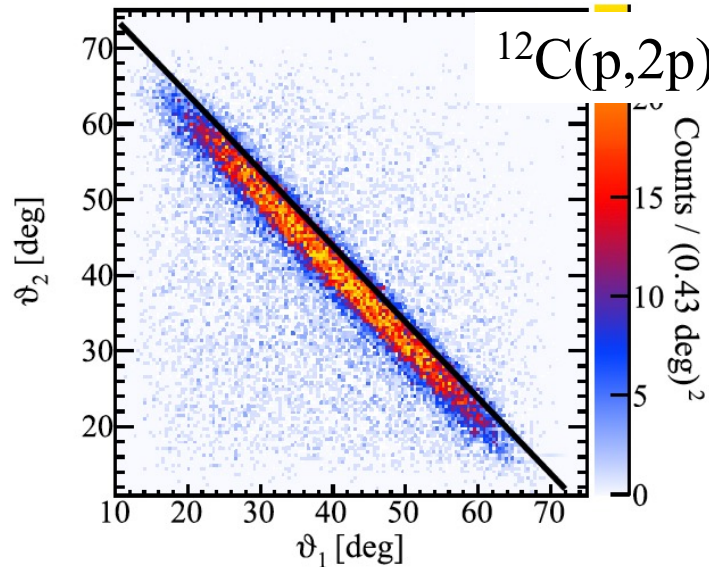

Novel detection system: Thick liquid hydrogen target + Proton Tracker

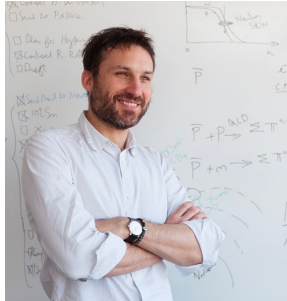

Prof. A. Obertelli
EPJA 50, 8 (2014)

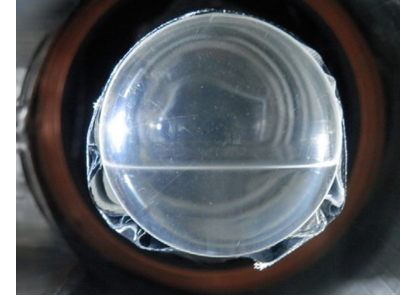

MINOS: 15 cm LH2 target + TPC Proton tracker

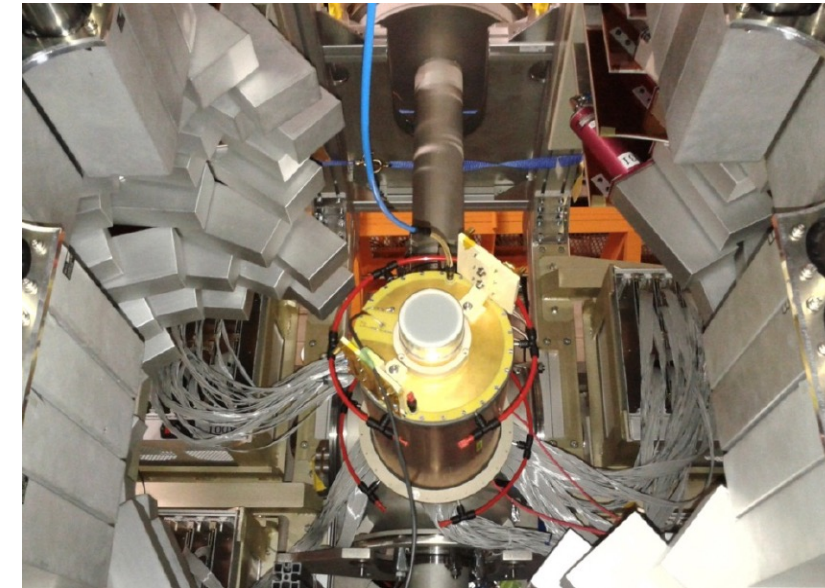
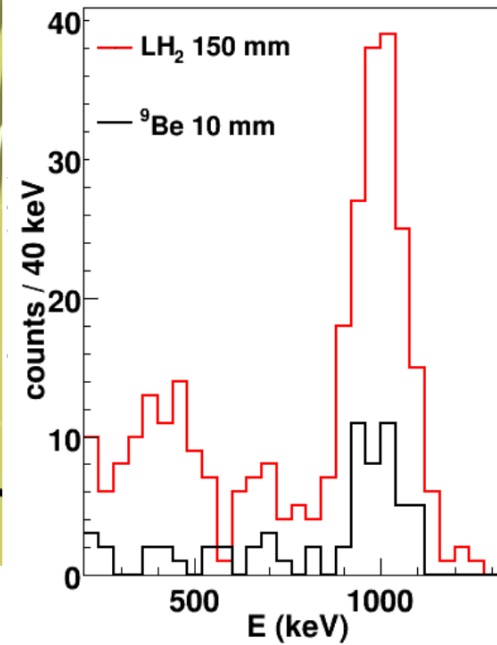
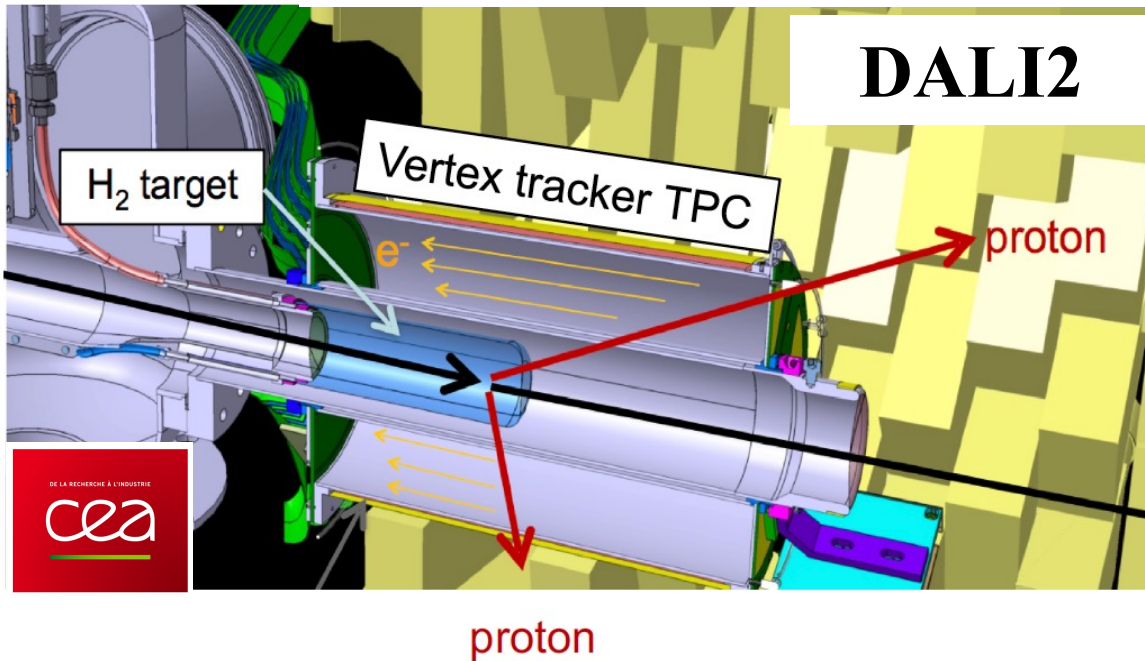

MINOS@RIBF

Gain in luminosity: 5~10 times while maintaining the E_γ resolution

Study of exotic nuclei with thick LH2 target

■ Stable

■ Unstable

■ Predicted

■ Even-even nuclei studied with MINOS at RIBF

Proton Number

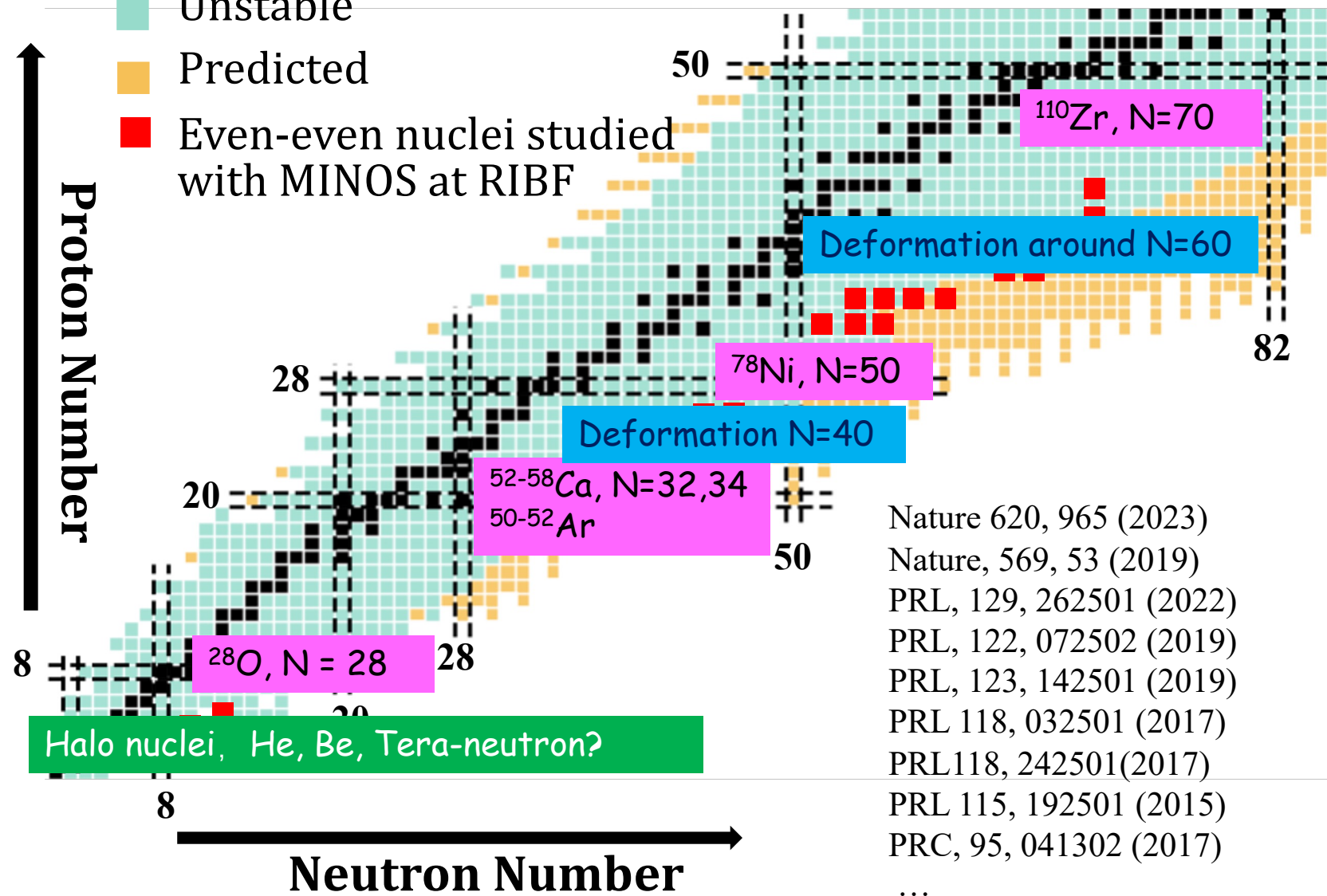

Nature 620, 965 (2023)
 Nature, 569, 53 (2019)
 PRL, 129, 262501 (2022)
 PRL, 122, 072502 (2019)
 PRL, 123, 142501 (2019)
 PRL 118, 032501 (2017)
 PRL118, 242501(2017)
 PRL 115, 192501 (2015)
 PRC, 95, 041302 (2017)
 ...

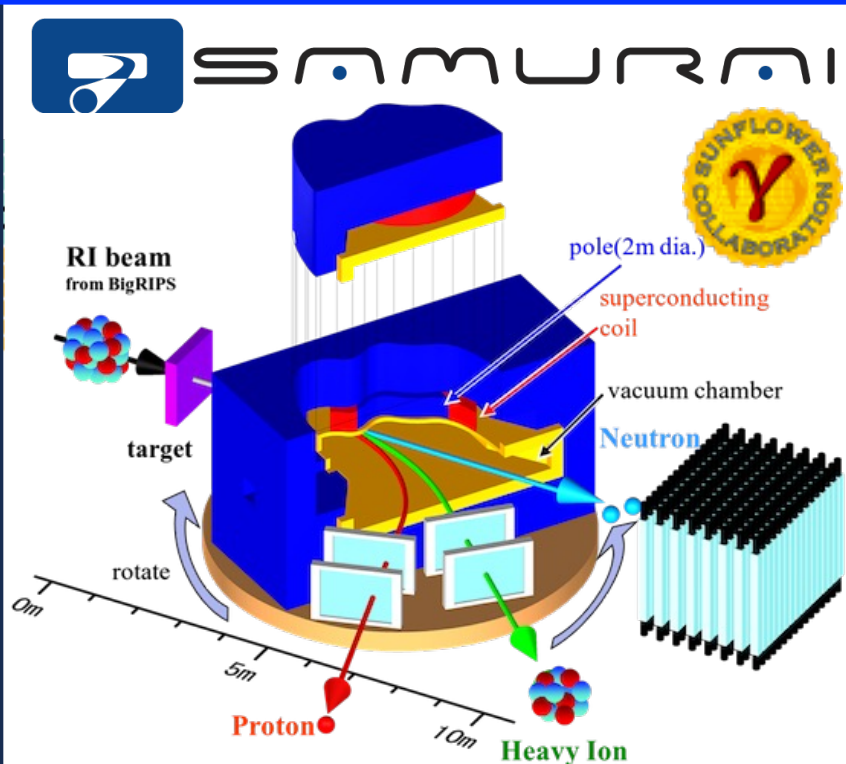

One setting for ^{52}Ar , $^{52-58}\text{Ca}$, ^{62}Ti

^{70}Zn beam 345MeV/u 200~250pA

150 mm MINOS LH2 target

226 NaI(Tl) γ detector array

7 day beam time

First observation of $N = 34$ subshell closure below $Z = 20$



^{52}Ar : most neutron-rich $N = 34$ nucleus accessible by experiment to date

^{53}K intensity: 1.0 pps

7 day beam time: 438 counts of ^{52}Ar

Emergency of New $N = 34$ subshell in ^{52}Ar

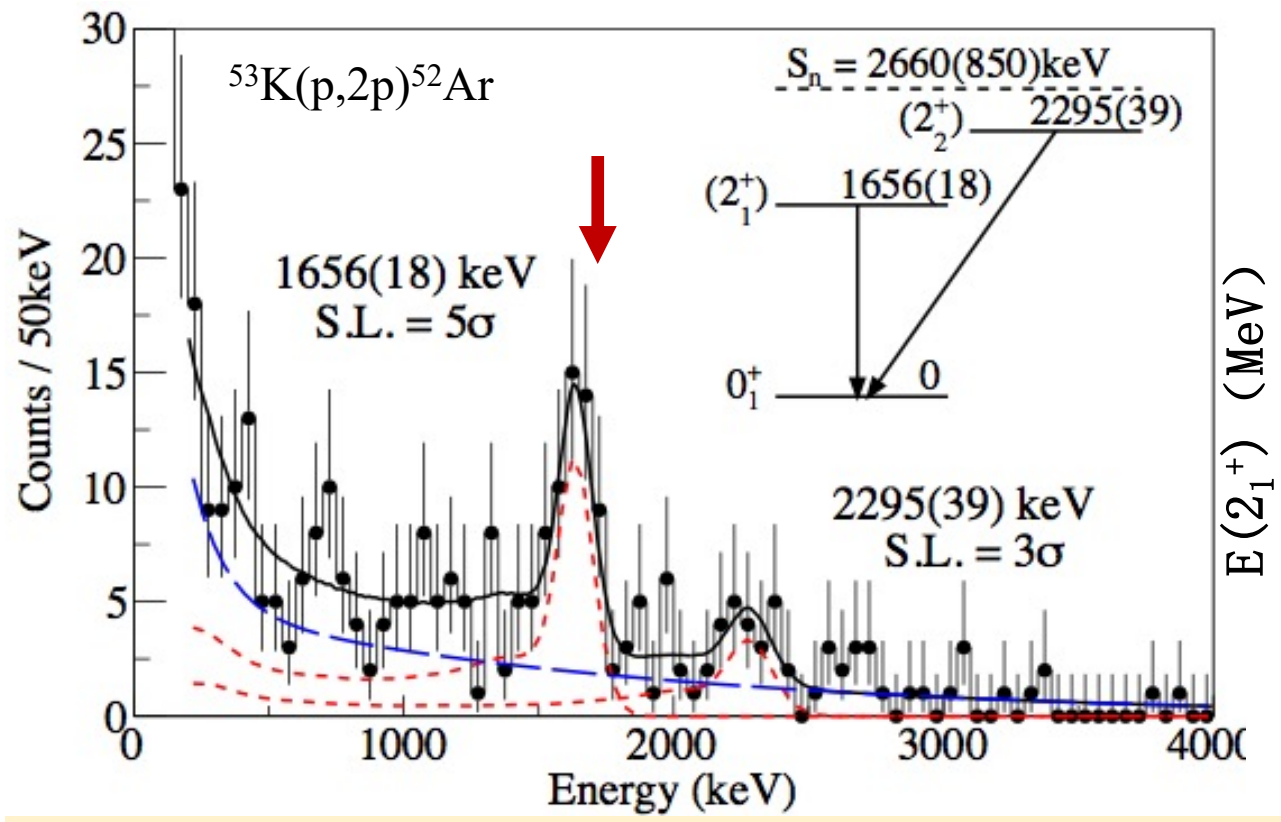

Data	VS-IMSRG	CC (1.8/2.0 EM)	LSSM
★ This work	— 1.8/2.0 EM	■ DCE-EOM	— SDPF-U
● Literature	- - $N^2\text{LO}_{\text{sat}}$	▲ 2PR-EOM	- - SDPF-MU (modified)
			- · - SDPF-MU (original)

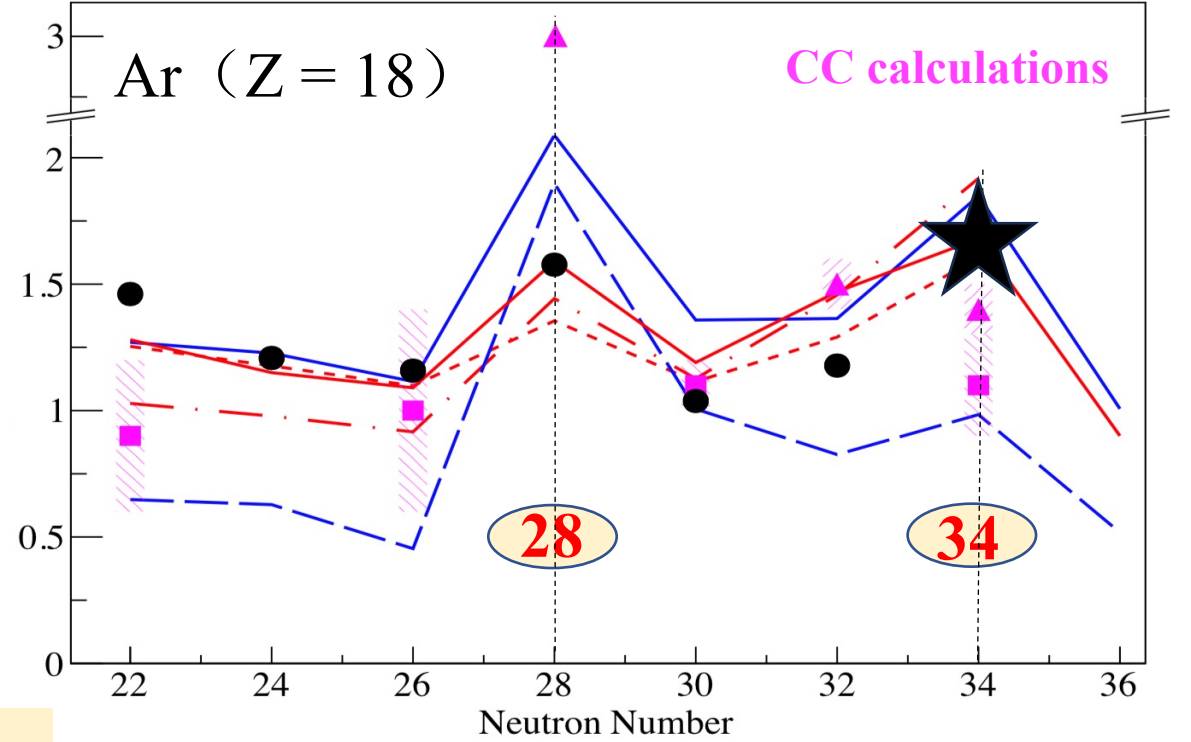

Theory: C. A. Bertulani, G. Hagen, J. D. Holt, Y. Utsuno

H.N. Liu*, A. Obertelli et al., PRL 122, 072502(2019) 12

Setup for QFS measurements worldwide



LH2+TPC

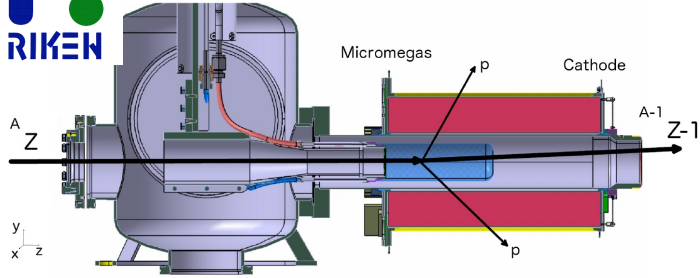

MINOS (Not maintained)

LH2+Si tracker

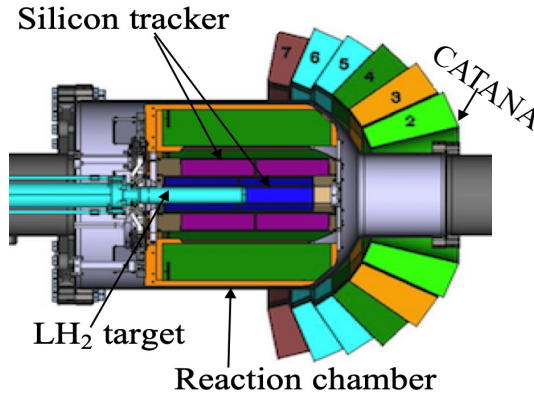

**STRASSE@SAMURAI
(under construction)**

LH2+Si tracker

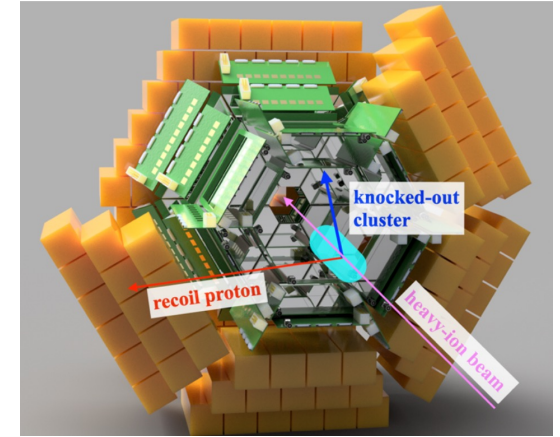

**TOGAXI@SAMURAI
(under construction)**

LH2+Si tracker

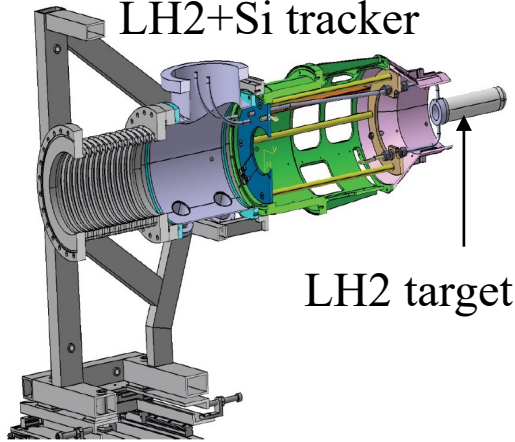

R3B@GSI/FAIR (in use)

LH2+Straw-tube gas detector

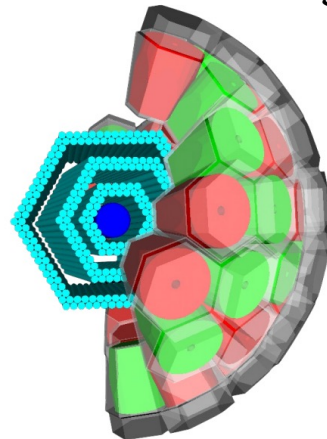

ExPRT@FRIB (under construction)

LH2 @ JINR (in use)

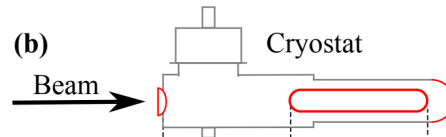

MULAN LH2 + Tracker

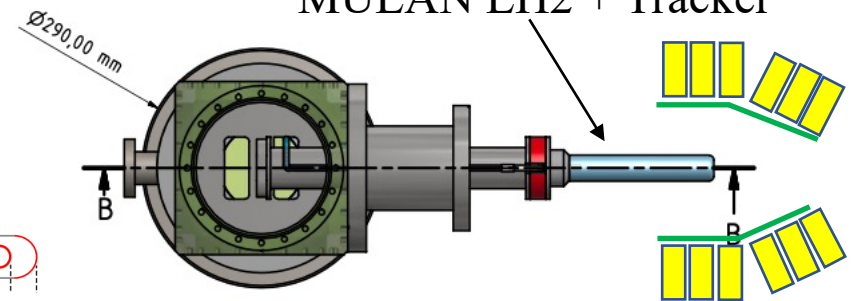

HIAF (under construction @ BNU)

Structure of the LH2 target system

Cryostat + Target cell

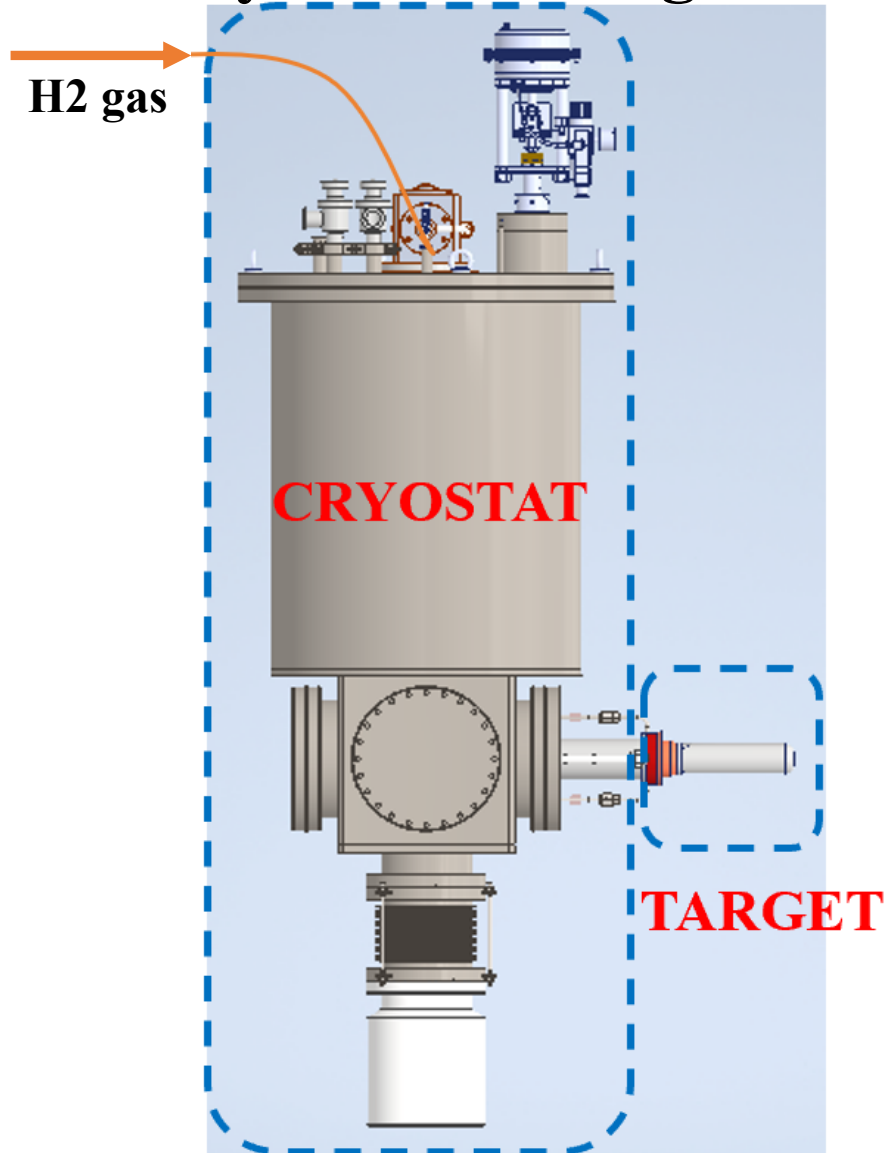

Gas circuit + Slow control

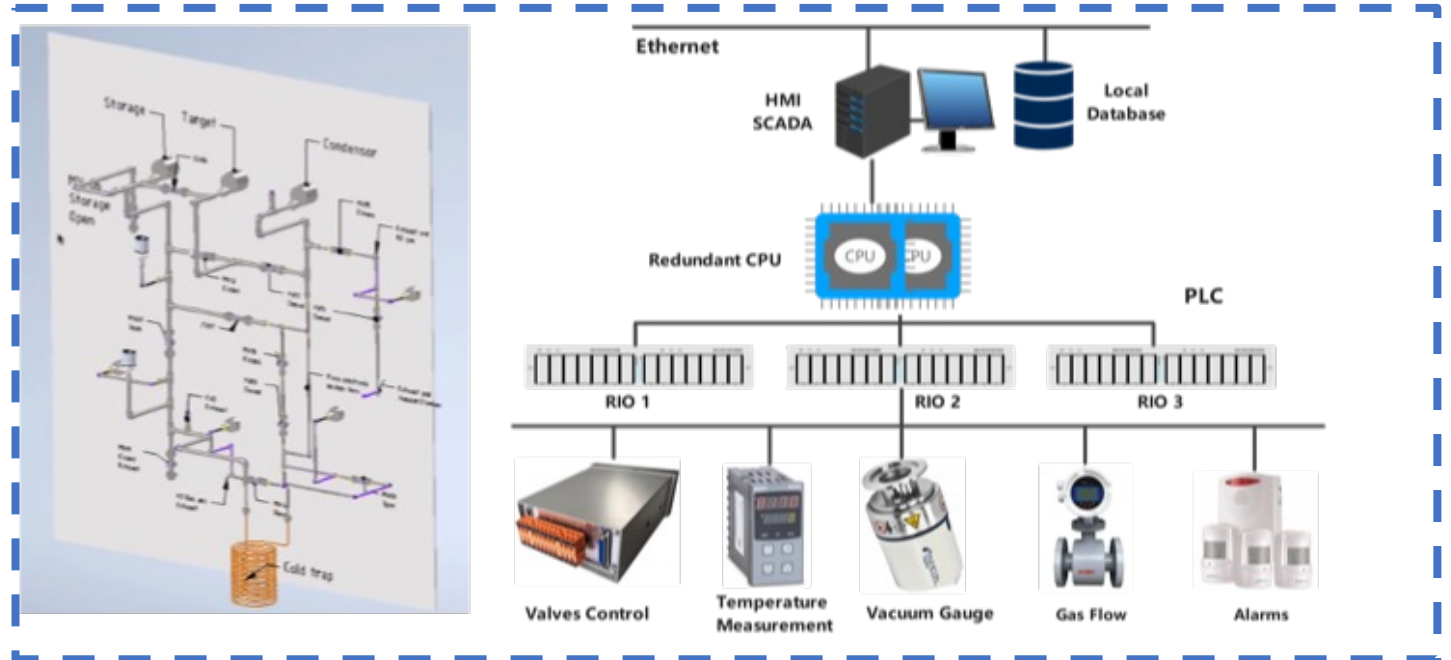

**Target cell: Thin window
LH2 at 20 K, Operated in vacuum
Continuous data taking: ~ 1 month
Remote control**

Limitations of MINOS+DALI2

MINOS (LH2 & TPC tracker)+ DALI2

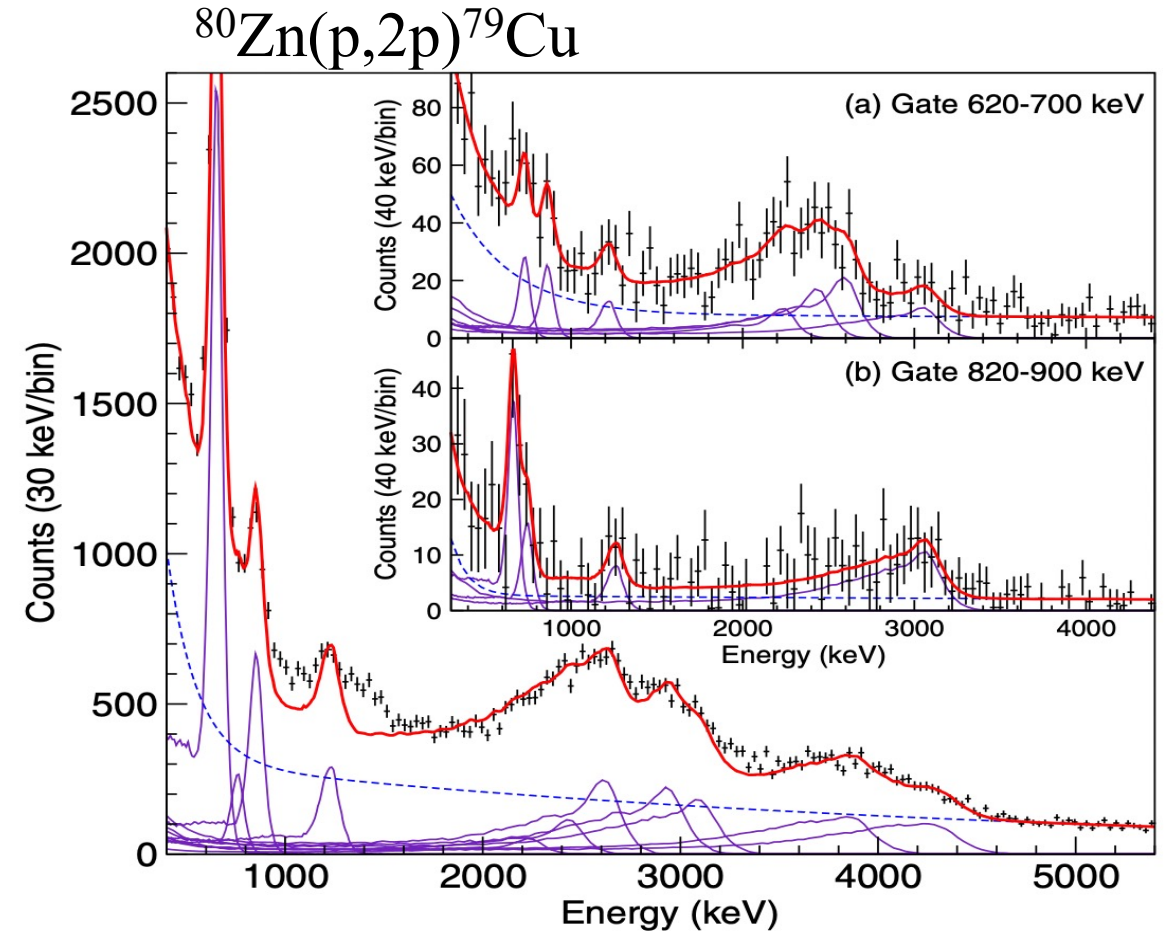
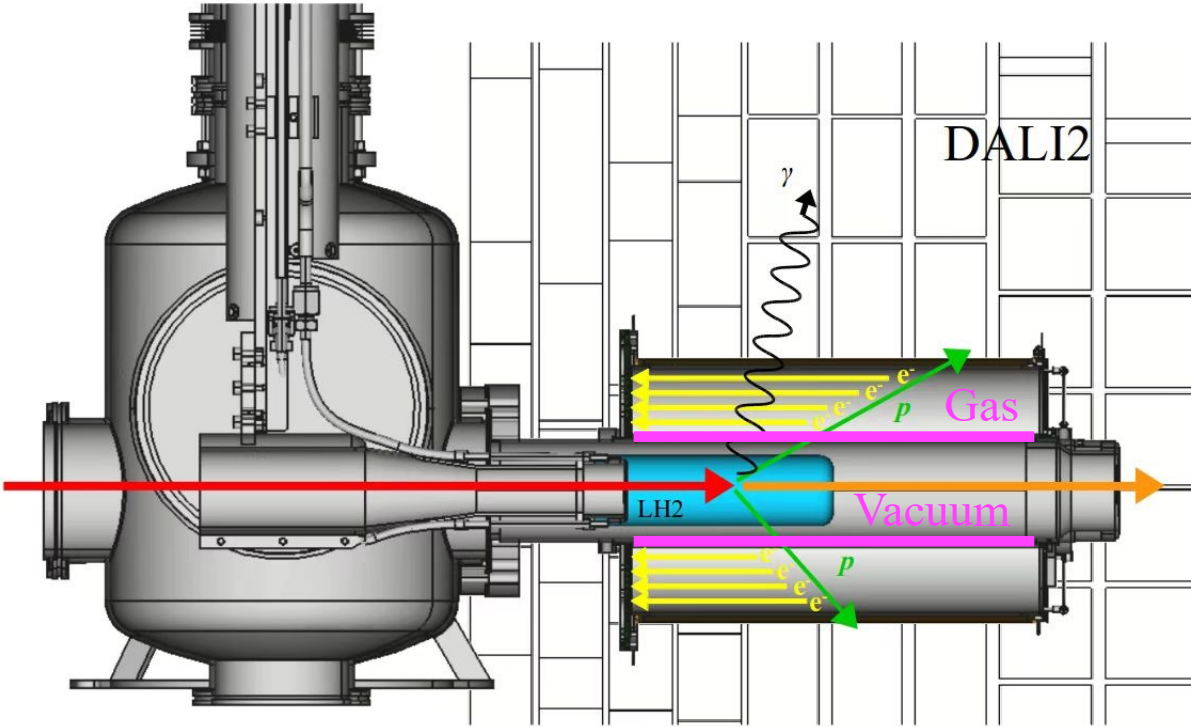

Limitation of MINOS

❖ **Moderate Vertex resolution:** 4.5 mm (FWHM)

❖ **Unsatisfactory angular resolution:** >16 mrad

Target radius: 26 mm +2mm Al chamber...

**γ -ray spectroscopy (MINOS+DALI2):
10% (FWHM) resolution at 1 MeV**

No missing mass spectroscopy



Development of STRASSE (LH2+Si Tracker) since 2019

H. N. Liu*, F. Flavigny et al., EPJA 59, 121 (2023).

Total electronics channels: 17358

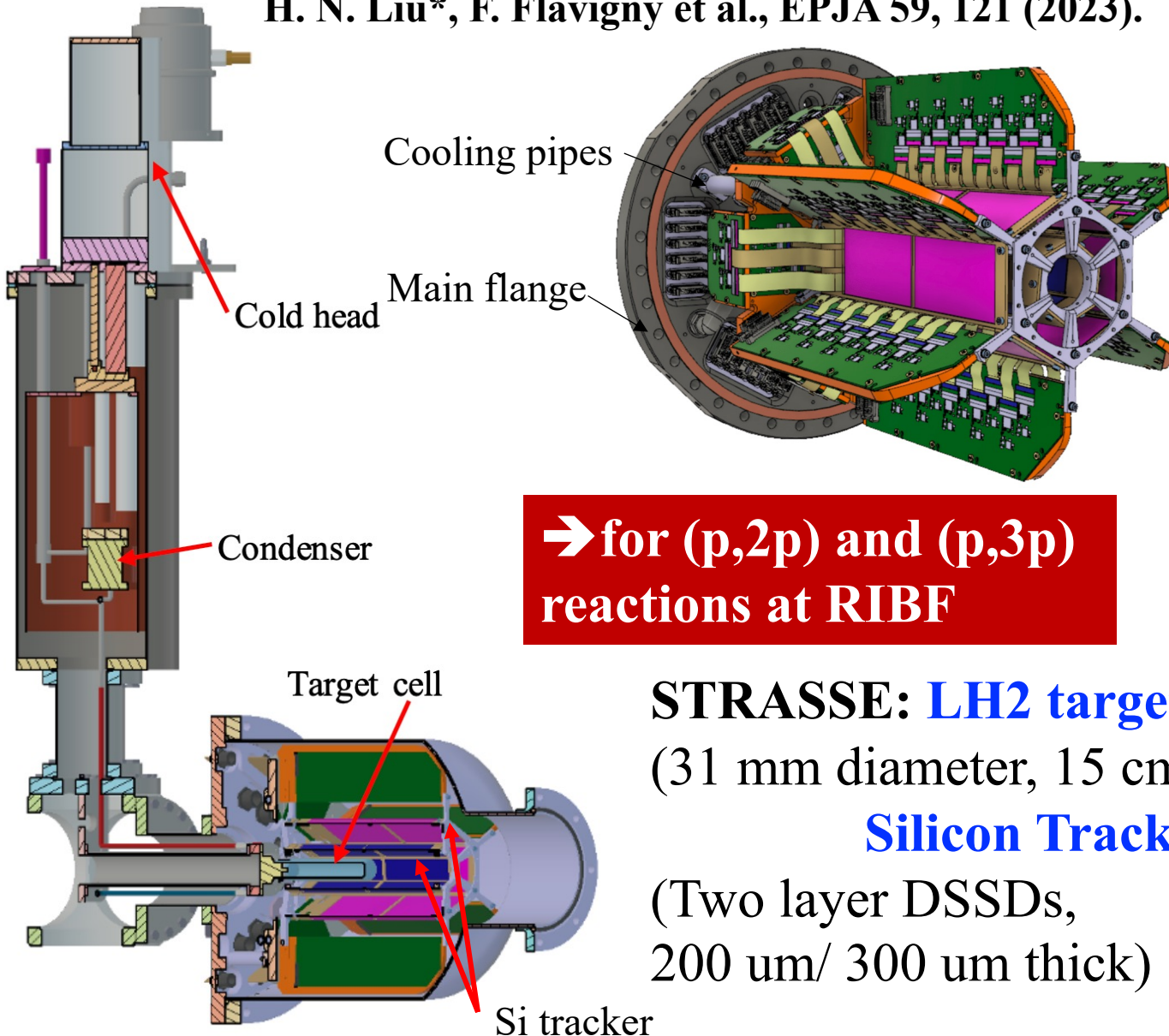

→ for (p,2p) and (p,3p) reactions at RIBF

STRASSE: LH2 target
 (31 mm diameter, 15 cm length)
Silicon Tracker
 (Two layer DSSDs,
 200 um/ 300 um thick)

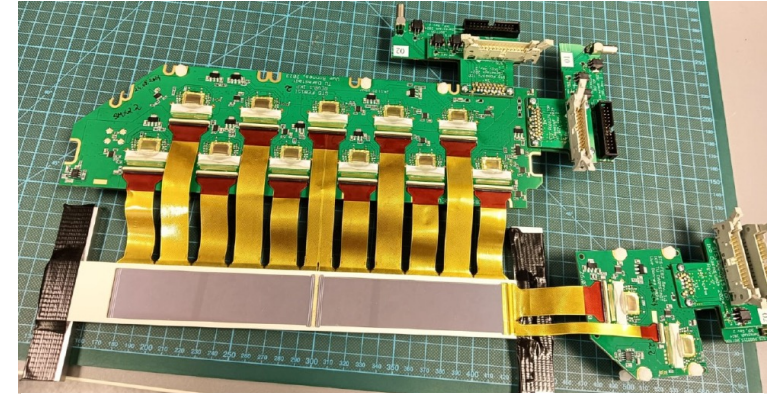

STS-XYTER2

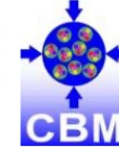
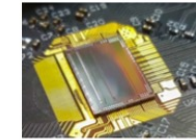

Microcable Capacitance: 0.15-0.25pF/cm

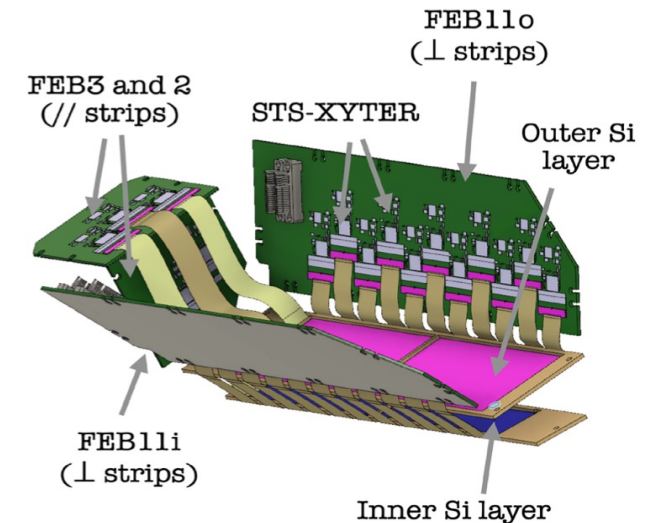

Missing-mass efficiency

250 MeV/u $^{17}\text{F}(p,2p)^{16}\text{O}$

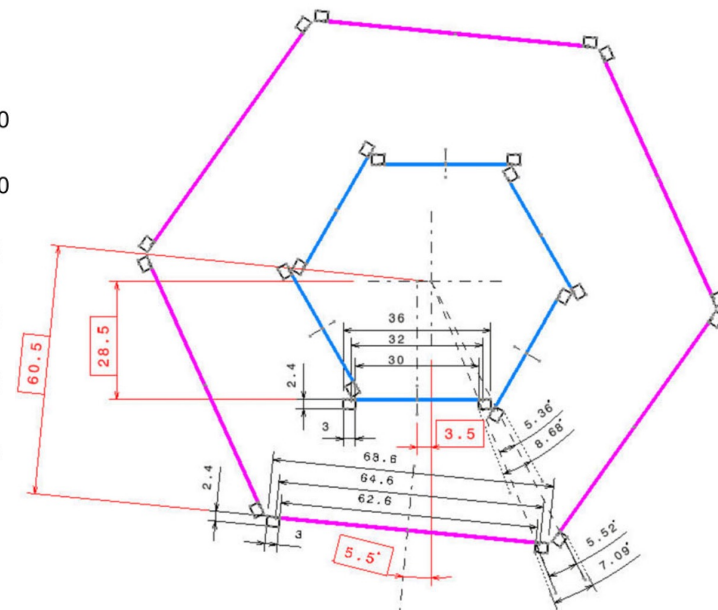
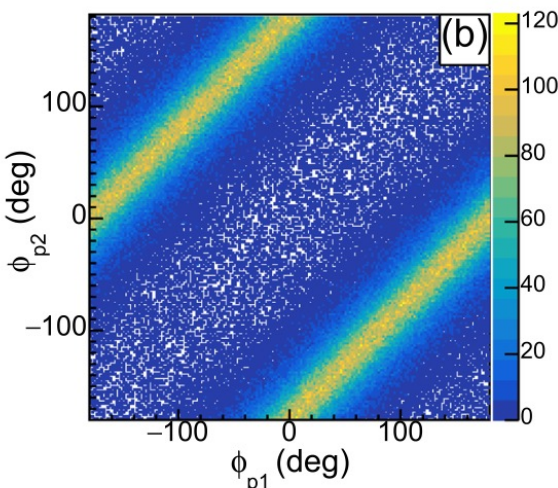
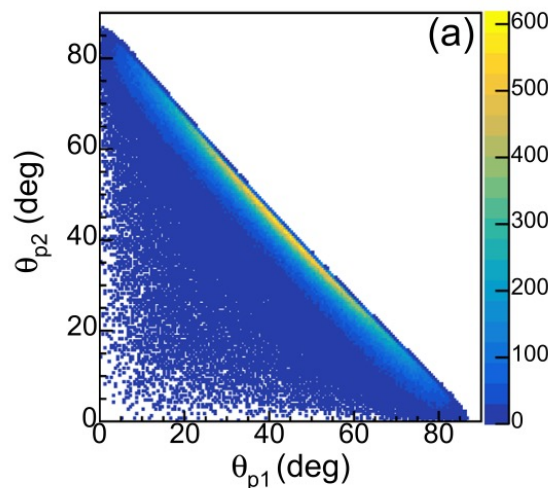
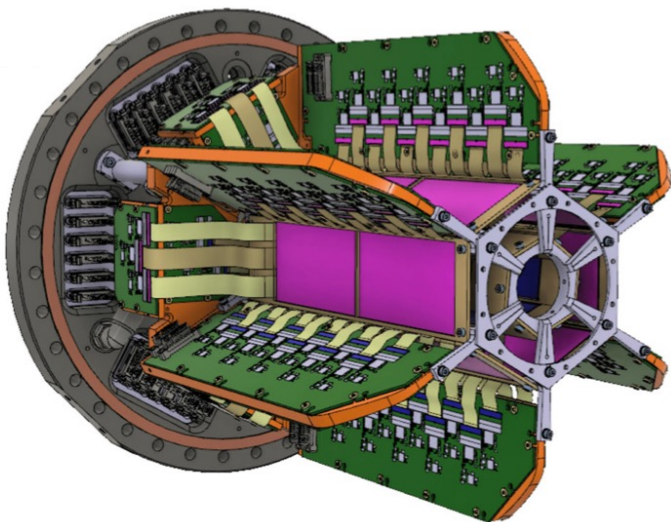

W/O CATANA	$\geq 1p$	2p
Acceptance in Phi	95%	73%
Acceptance in Theta	90%	67%
Efficiency	86%	49%

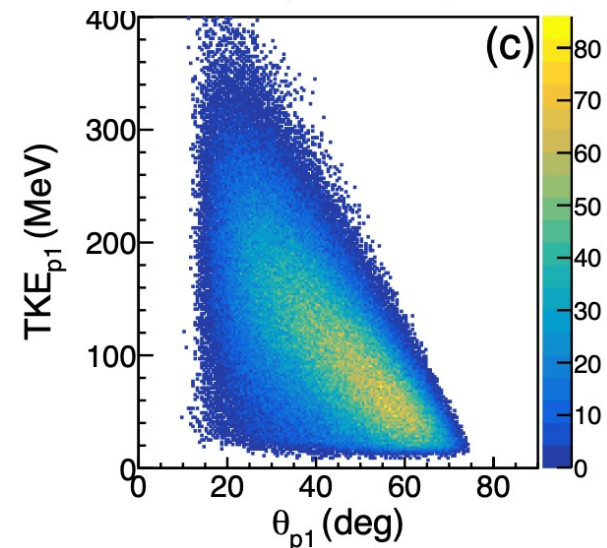
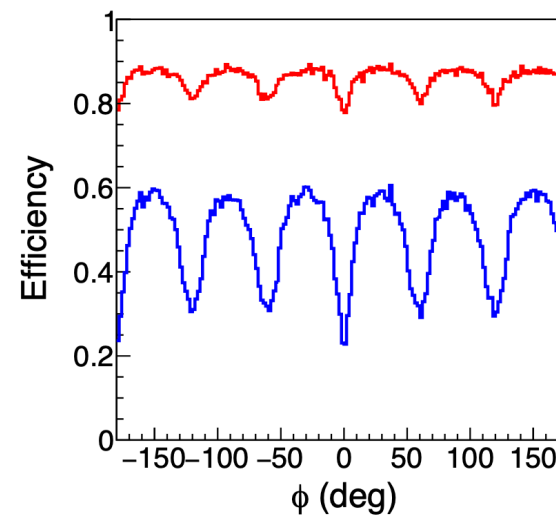
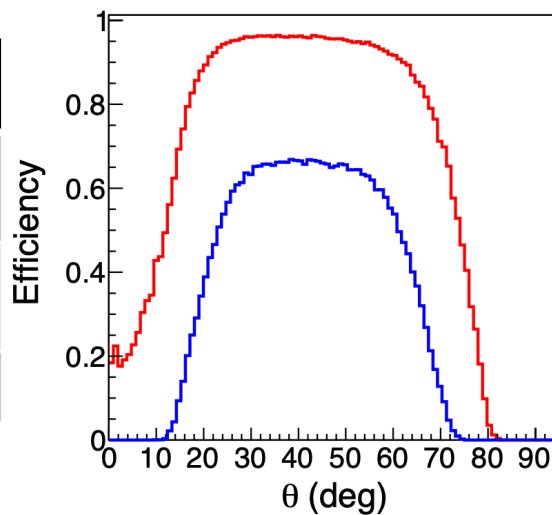

Development of STRASSE (LH2+Si Tracker) since 2019

H. N. Liu*, F. Flavigny et al., EPJA 59, 121 (2023).

Used at RIBF in May of 2025

~60 collaborators from
16 institutes/universities

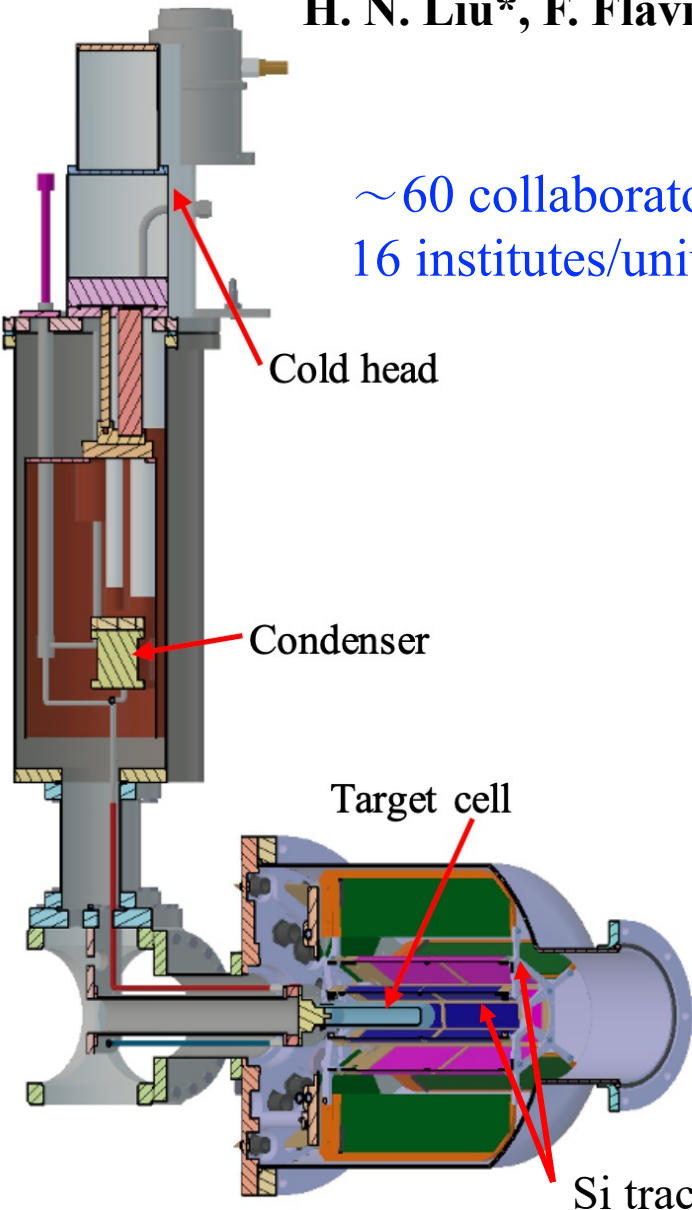

→ for (p,2p) and (p,3p) reactions at RIBF

	STRASSE
Vertex res.:	0.5 mm (FWHM)
Angular res.:	5 mrad in σ
Missing-mass res.:	<2 MeV in σ
Momentum res.:	3~5 MeV/c

	MINOS
Vertex res.:	5 mm (FWHM)
Angular res.:	16 mrad in σ
Missing-mass res.:	5 MeV in σ
Momentum res.:	40 MeV/c in σ

Approved experiments with STRASSE at RIBF (~8 exp./ 60 days)

NP2512-SAMURAI84	H. Liu	First in-beam gamma spectroscopy of ^{48}S	^{70}Zn 345 MeV/u	6.5 days
NP2412-SAMURAI79R1	Y. Nakajima	Study of de-excitation of $^{15}\text{N}^*$, $^{15}\text{O}^*$, and $^{16}\text{O}^*$ for new neutrino observation at giant water Cherenkov detectors	^{18}O 230 MeV/u	4.5 days
NP2412-SAMURAI67R1	Z. H. Yang	Halo structure of the isomeric state $^{12}\text{Be}(0_2^+)$ probed by using a tertiary isomer beam	^{18}O 250 MeV/u	5.5 days
NP2312-SAMURAI75R1	Y. Matsuda	Study of neutron single-particle states in carbon and calcium isotopic chains using (p,pn) reactions	^{48}Ca , ^{70}Zn 345 MeV/u	6.5 days
NP2212-SAMURAI74	K. Miki	Correlations in multi-neutron systems	^{18}O 250 MeV/u	11.5 days
NP2112-SAMURAI65	H. Liu	Search for the first excited 0^+ state in the doubly-magic nucleus ^{54}Ca	^{70}Zn 345 MeV/u	6.5 days
NP2112-SAMURAI69	A. Obertelli	Momentum distribution of deeply-bound nucleons	^{16}O , ^{48}Ca 345 MeV/u	9.5 days
NP1812-SAMURAI47	T. Nakamura	Multi-neutron $4n$ and $6n$ states in extremely neutron-rich nuclei beyond the neutron drip line	^{18}O 345MeV/u	Apr 2024, 5 days

High Intensity Heavy-ion Accelerator Facility

Beam energy: Hundred MeV/u ~ A few GeV/u

Booster Ring:

- Circumference: 569 m
- Rigidity: 34 Tm

HIRIBLL

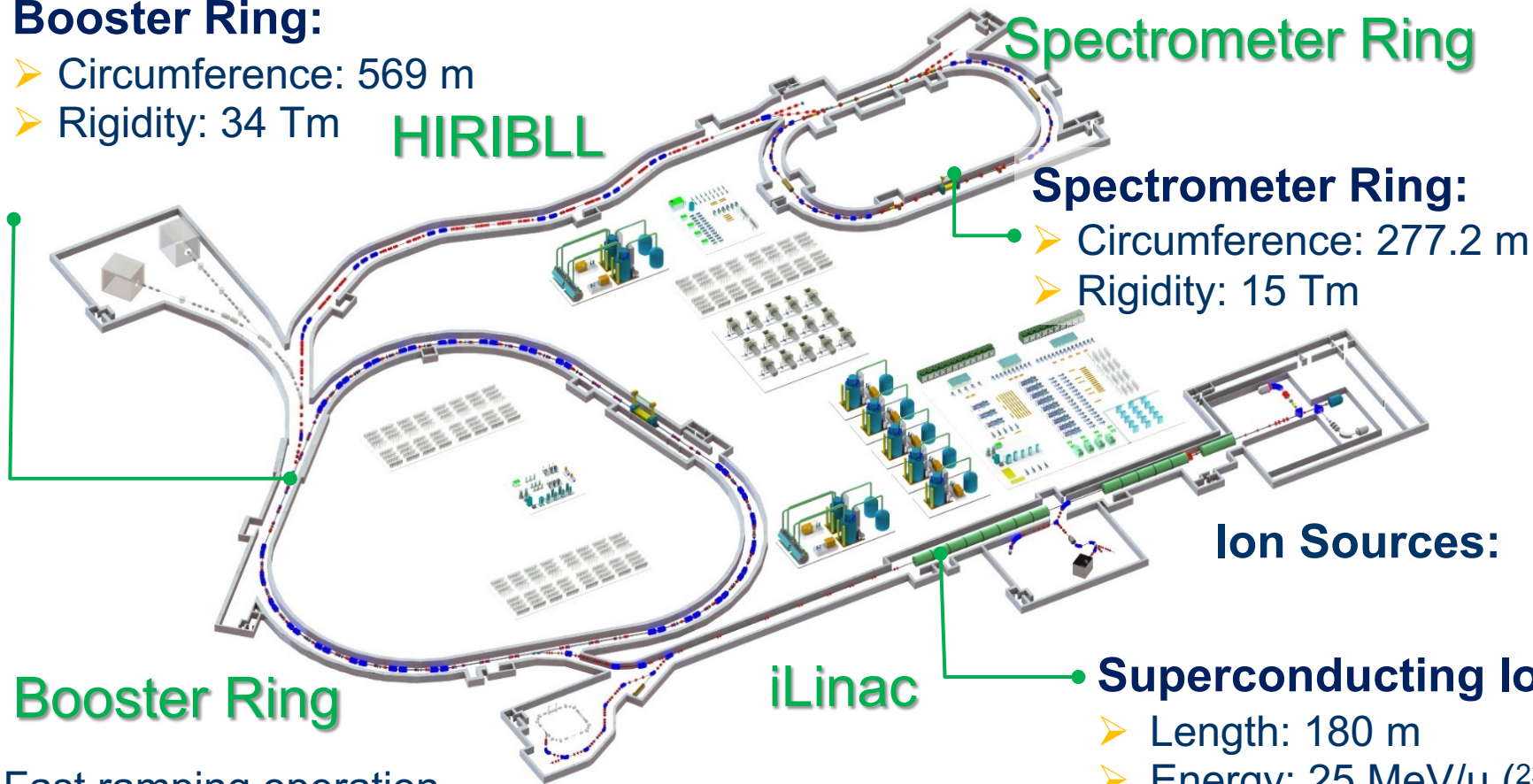

Spectrometer Ring

Spectrometer Ring:

- Circumference: 277.2 m
- Rigidity: 15 Tm

Booster Ring

Fast ramping operation
Repetition rate: 3 Hz

iLinac

Superconducting Ion Linac:

- Length: 180 m
- Energy: 25 MeV/u ($^{238}\text{U}^{34+}$)

Ion Sources:

Ions	Energy (GeV/u)	Intensity (ppp)
p	9.3	2.0×10^{12}
$^{18}\text{O}^{6+}$	2.6	6.0×10^{11}
$^{78}\text{Kr}^{19+}$	1.7	3.0×10^{11}
$^{209}\text{Bi}^{31+}$	0.85	1.2×10^{11}
$^{238}\text{U}^{35+}$	0.835	1.0×10^{11}

Developing a Multi-platform LH₂ target for HIAF

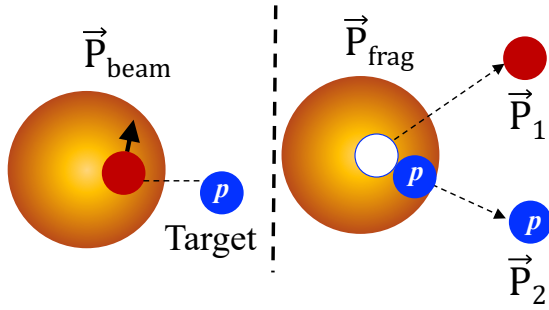

Possible Physics Program

(p, pN)
Shell evolution & Reaction Mechanisms

R. Taniuchi et al., Nature 569, 53 (2019).

T. Pohl, Y. L. Sun* et al, PRL (accepted).

$(p, 2pn), (p, pd)$
Short-range correlations

M. Patsyuk et al. Nat. Phys. 17, 693 (2021).

$(p, p\alpha)$
Clustering & Multi-neutron ...

J. Tanaka et al., Science 371,260 (2021).

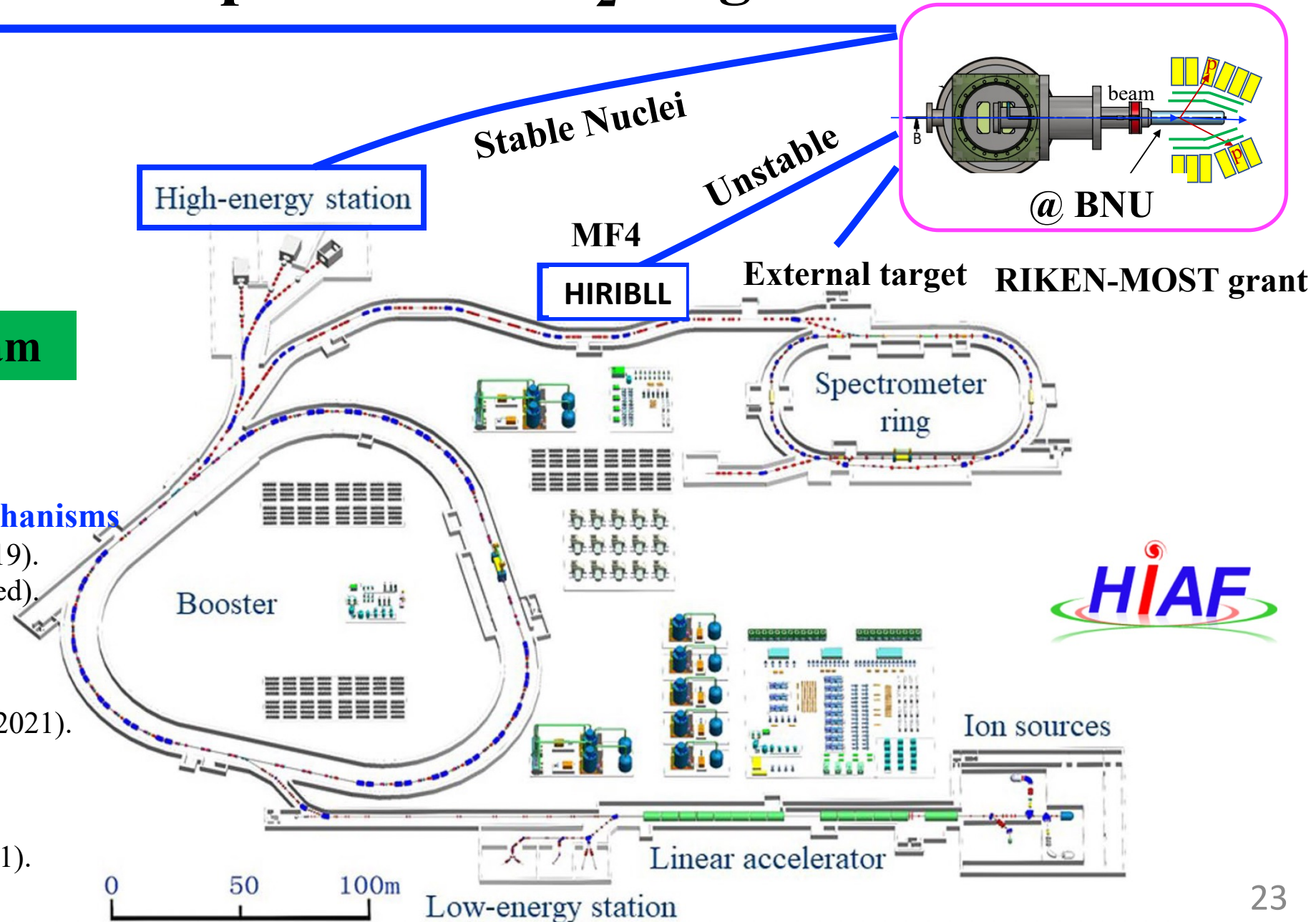

The MULAN target @ HIAF

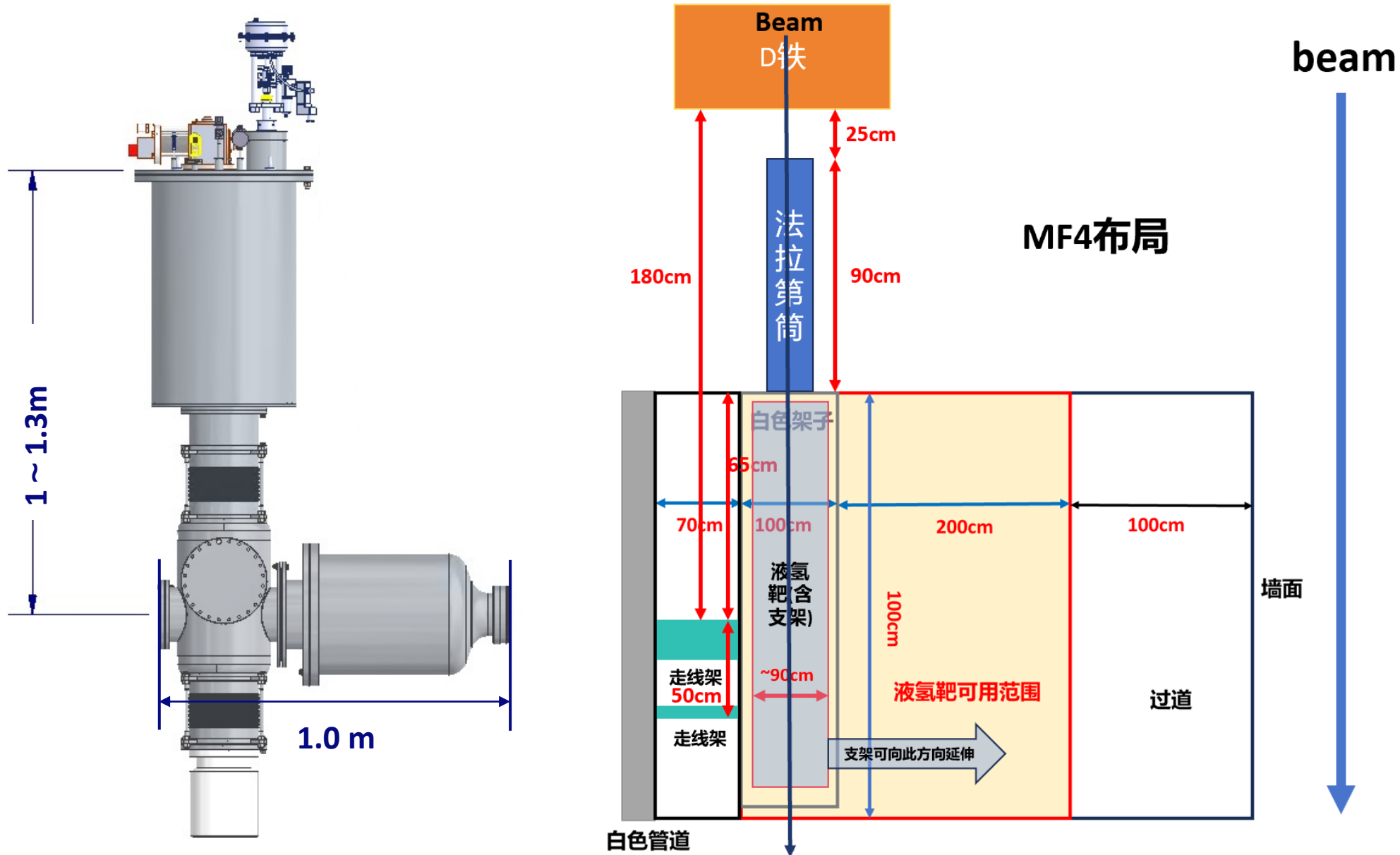

Summary



The LH2 target is a powerful tool in the study of RI Isotope Physics.

Development of the STRASSE system at RIBF

→ Simultaneous in-beam gamma and particle spectroscopy

Development of the MULAN target system at HIAF

→ Exotic nuclear structure in heavier mass region & SRC study

Preparing target cell for Hyperon-Nucleon Spectrometer

